



FOCUS LCDs

LCDs MADE SIMPLE®

Ph. 480-503-4295 | NOPP@FocusLCDs.com

TFT | OLED | GRAPHIC | CHARACTER | UWVD | SEGMENT | CUSTOM

Graphic OLED Module

Part Number

O12864B-GW-TW3

Overview:

- 128x64 Graphic OLED
- White Pixel Color
- Overall Size: 60.5mm x 37.0mm
- Parallel Interface
- -40C to 70C Operating Temperature
- 1.65V to 3.5V
- Controller: SSD1309ZC
- RoHS Compliant

Graphic OLED Features:

Resolution: 128 x 64

Interface: Parallel

Controller: SSD1309ZC

RoHS Compliant

General Information Items	Specification	Unit	Note
	Main Panel		
Viewing Area	60.5 x 37.0	mm	-
Pixel Color	White	-	-
Viewing Direction	>160	degrees	-
Voltage	2.8	V	-
Resolution	128x64	-	-
Controller IC	SSD1309ZC	-	-
Interface	Parallel	-	-
Operating temperature	-40~+70	°C	-
Storage temperature	-40~+85	°C	-

Mechanical Information

Item		Min	Typ.	Max	Unit	Note
Module size	X (Width)	-	60.5	-	mm	-
	Y (Height)	-	37.0	-	mm	-
	Z (Depth)	-	-	2.0	mm	-

1. Outline Dimensions

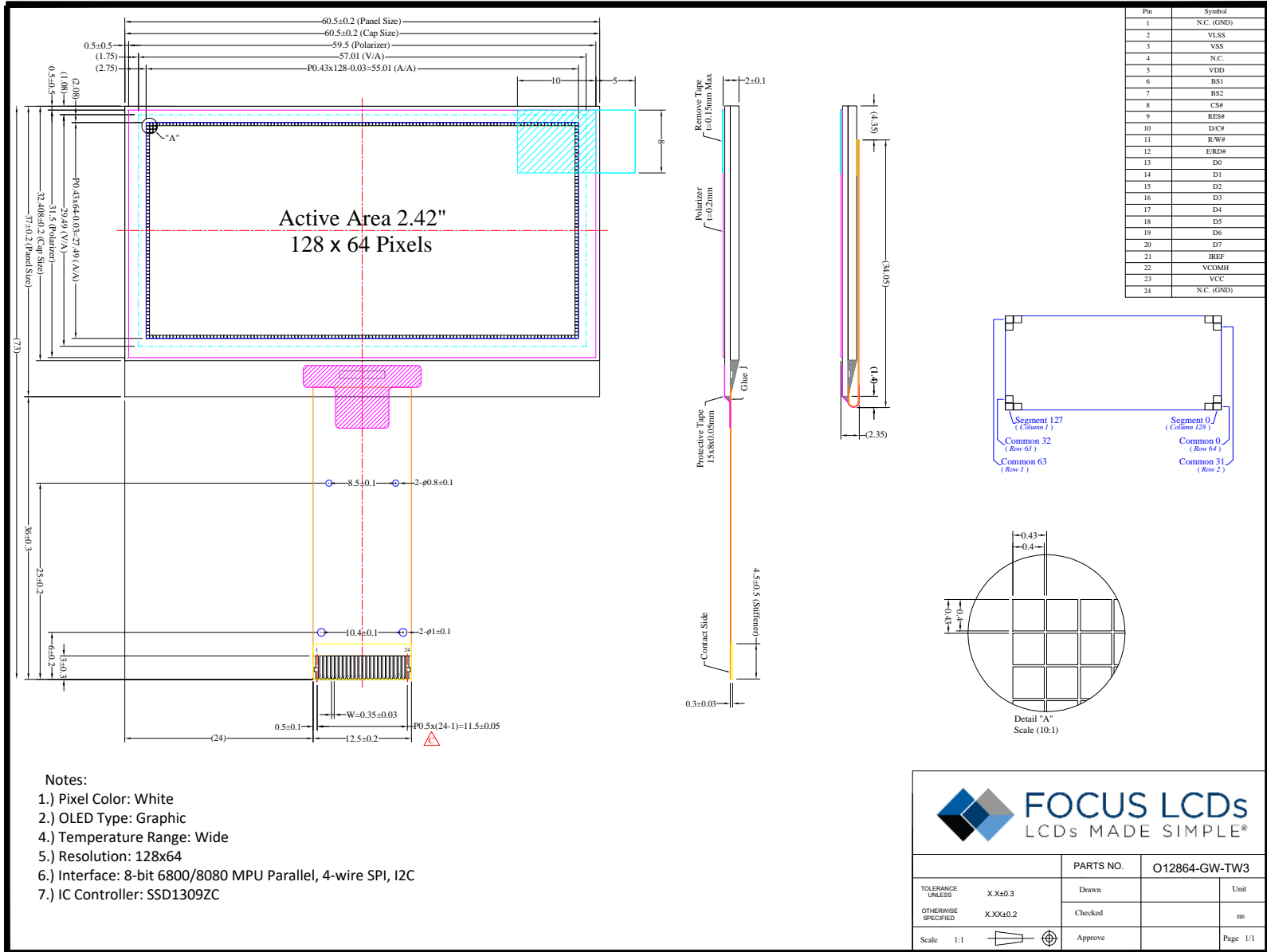

2. Input Terminal Pin Assignment

Recommended Connector: FH19C-24S-0.5SH(10)

NO.	Symbol	Description
1	NC	No connection
2	VSS	Ground
3	VSS	Ground
4	NC	No connection
5	VDD	Power Supply Input
6	BS1	MCU Bus Interface Selection Pins
7	BS2	MCU Bus Interface Selection Pins
8	CS#	Chip Select Input
9	RES#	Power Reset for Controller and Driver
10	D/C	Data Control Pad
11	WR#	Write Select
12	RD#	Read Select
13-20	D0-D7	Host Data Input/Output Bus
21	IREF	Current Reference for Brightness Adjustment
22	VCOMH	Voltage Output High Level for COM Signal
23	VCC	Power Supply for OEL Panel
24	NC	No connection

3. Optical Characteristics

Characteristic	Symbol	Condition	Min	Typ.	Max	Unit
Brightness	L	$V_{DD} = 3V$ $V_{CC} = 14V$	100	120	-	cd/m ²
Operating Life Time	-	-	30000	-	-	hours
Frame Frequency	Fr	-	-	100	-	Hz
White Color	CIE	-	X=0.26 Y=0.29	X=0.30 Y=0.33	X=0.34 Y=0.37	-
Contrast Ratio	CR	10000:1	-	-	-	-
Viewing Angle	$\Delta\theta$	-	160	-	-	degrees

4. DC Electrical Characteristics

Characteristics	Symbol	Conditions	Min	Typ.	Max	Unit
Supply Voltage for Logic	V_{DD}	$V_{DD1} \Rightarrow$ 1.65V to 3.5V	1.65	-	3.5	V
Supply Voltage for Operating	V_{CC}		7.0	-	16.0	V
High Level Input	V_{IH}		$0.8V_{DD}$	-	V_{DD1}	V
Low Level Input	V_{IL}		V_{SS}	-	$0.2V_{DD}$	V
High Level Output	V_{OH}		$0.8V_{DD}$	-	V_{DD}	V
Low Level Output	V_{OL}		V_{SS}	-	$0.2V_{DD}$	V

NOTE: If the maximum rating of the above parameters is exceeded, even momentarily, the quality of the product may be degraded. The maximum ratings specify the values which the product may be physically damaged if exceeded. Be sure to use the product within the range of the specified parameters.

5. Timing Characteristics

5.1 6800-Series MPU Parallel Interface Timing Characteristics

Parameter	Symbol	Min	Max	Unit
Clock Cycle Time	t_{cyc}	300	-	ns
Address Setup Time	t_{AS}	20	-	ns
Address Hold Time	t_{AH}	0	-	ns
Write Data Setup Time	t_{DSW}	40	-	ns
Write Data Hold Time	t_{DHW}	20	-	ns
Read Data Hold Time	t_{DHR}	20	-	ns
Output Disable Time	t_{OH}	-	70	ns
Access Time	t_{ACC}	-	140	ns
Chip Select Low Pulse Width (Read)	PW_{CSL}	120	-	ns
Chip Select Low Pulse Width (Write)		60		ns
Chip Select High Pulse Width (Read)	PW_{CSH}	60	-	ns
Chip Select High Pulse Width (Write)		60		ns
Rise Time	t_r	-	40	ns
Fall Time	t_f	-	40	ns

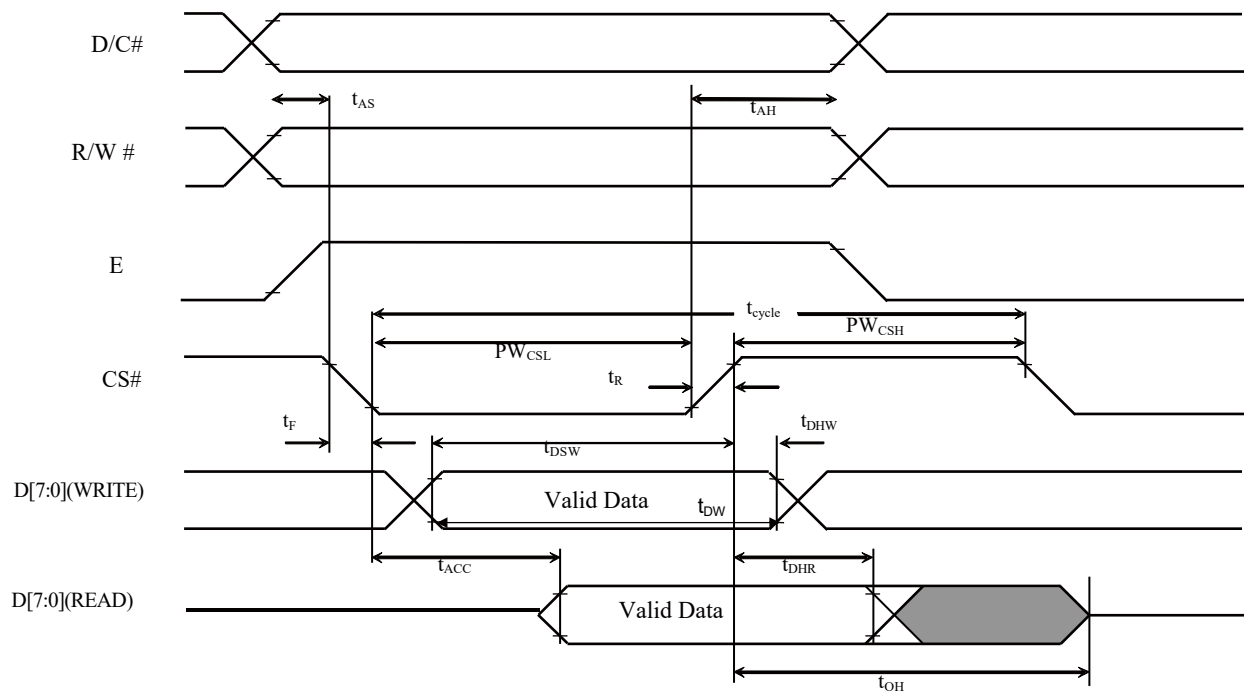

5.2 8080-Series MPU Parallel Interface Timing Characteristics

Parameter	Symbol	Min	Max	Unit
Clock Cycle Time	t_{cycle}	300	-	ns
Address Setup Time	t_{AS}	20	-	ns
Address Hold Time	t_{AH}	0	-	ns
Write Data Setup Time	t_{DSW}	40	-	ns
Write Data Hold Time	t_{DHW}	15	-	ns
Read Data Hold Time	t_{DHR}	20	-	ns
Output Disable Time	t_{OH}	-	70	ns
Access Time	t_{ACC}	-	140	ns
Read Low Time	$t_{PWL R}$	120	-	ns
Write Low Time	$t_{PWL W}$	60	-	ns
Read High Time	$t_{PWH R}$	60	-	ns
Write High Time	$t_{PWH W}$	60	-	ns
Chip Select Setup Time	t_{CS}	0	-	ns
Chip Select Hold Time to Read Signal	t_{CSH}	0	-	ns
Chip Select Hold Time	t_{CSF}	20	-	ns
Rise Time	t_r	-	40	ns
Fall Time	t_f	-	40	ns
Data Write Time	t_{DW}	70	-	ns

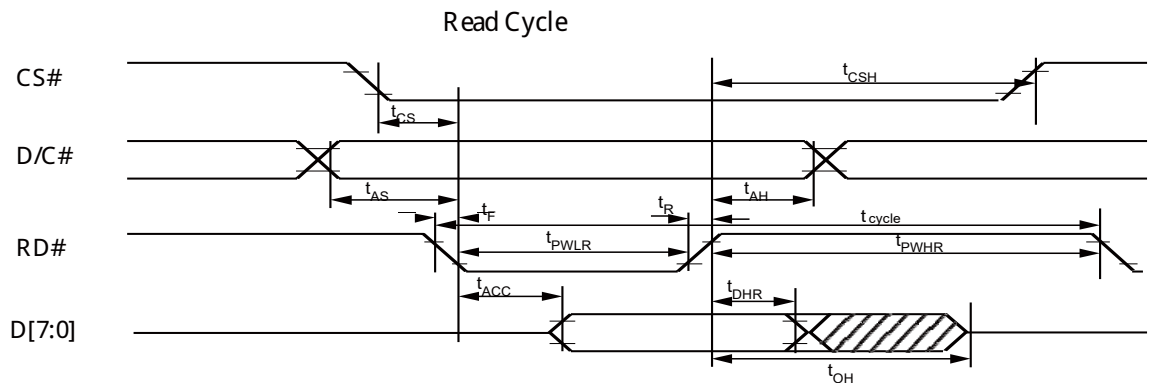
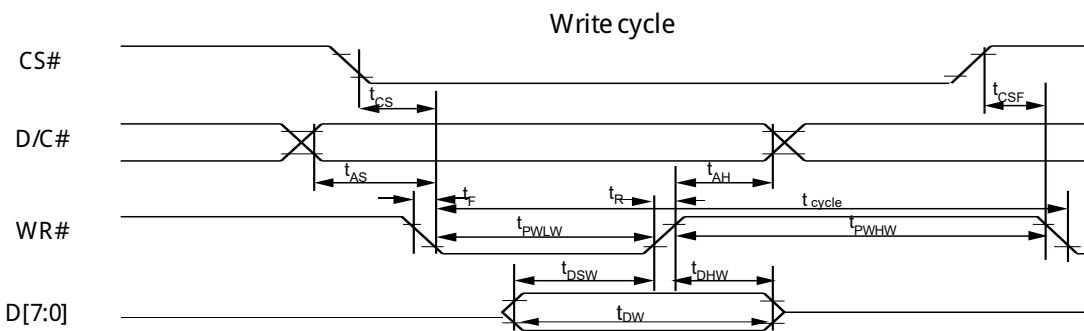

5.3 Serial Interface Timing Characteristics

Parameter	Symbol	Min	Max	Unit
Clock Cycle Time	t_{cycle}	100	-	ns
Address Setup Time	t_{AS}	15	-	ns
Address Hold Time	t_{AH}	15	-	ns
Chip Select Setup Time	t_{CSS}	20	-	ns
Chip Select Hold Time	t_{CSH}	50	-	ns
Write Data Setup Time	t_{DSW}	15	-	ns
Write Data Hold Time	t_{DHW}	15	-	ns
Clock Low Time	t_{CLKL}	50	-	ns
Clock High Time	t_{CLKH}	50	-	ns
Rise Time	t_{r}	-	40	ns
Fall Time	t_{f}	-	40	ns
Data Write Time	t_{DW}	55	-	ns

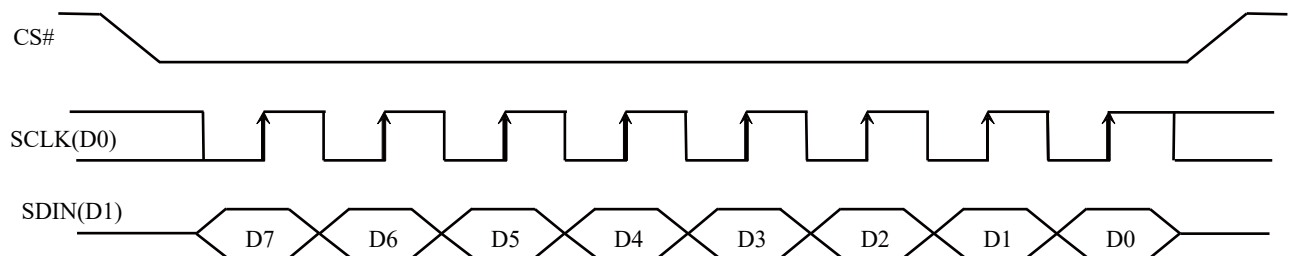
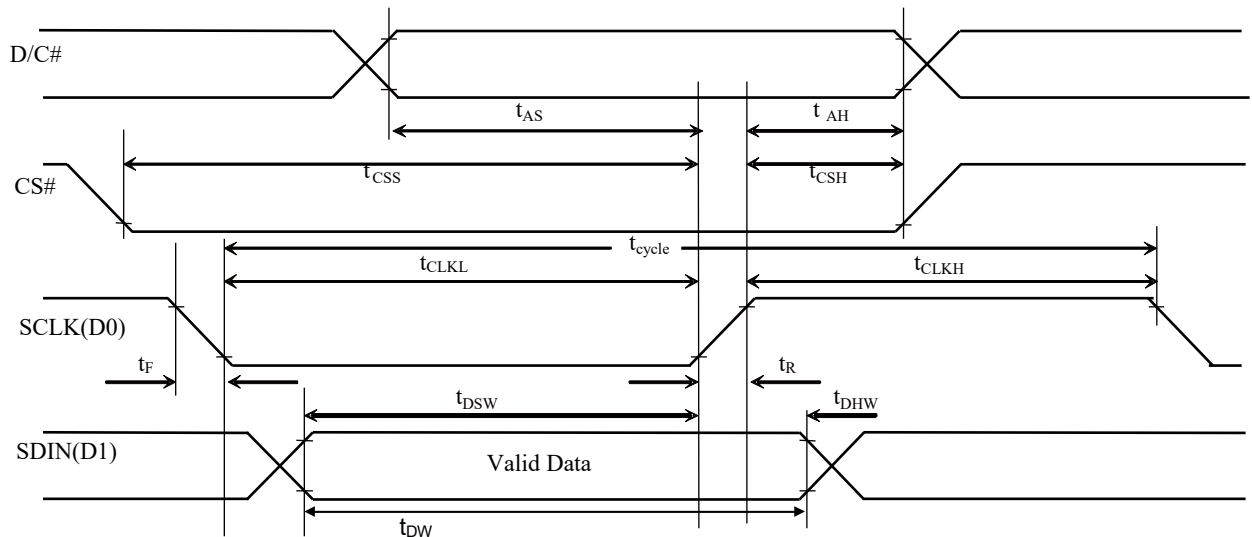

5.4 I²C Interface Timing Characteristics

Parameter	Symbol	Min	Max	Unit
Clock Cycle Time	t_{cycle}	2.5	-	μs
Start Condition Hold Time	t_{HSTART}	0.6	-	μs
Data Hold Time (for "SDA _{OUT} " Pin)	t_{HD}	0	-	ns
Data Hold Time (for "SDA _{IN} " Pin)		300		
Data Setup Time	t_{SD}	100	-	ns
Start Condition Setup Time (Only relevant for a repeated Start Condition)	t_{SSSTART}	0.6	-	μs
Stop Condition Setup Time	t_{SSSTOP}	0.6	-	μs
Rise Time for Data and Clock Pin	t_{r}	-	300	ns
Fall Time for Data and Clock Pin	t_{f}	-	300	ns
Idle Time before a New Transmission can Start	t_{IDLE}	1.3	-	μs

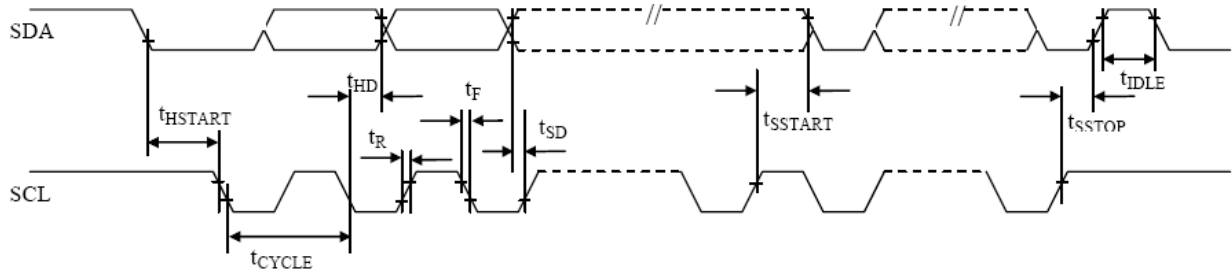

6. Cautions and Handling Precautions

6.1 Handling and Operating the Module

1. When the module is assembled, it should be attached to the system firmly. Do not warp or twist the module during assembly work.
2. Protect the module from physical shock or any force. In addition to damage, this may cause improper operation or damage to the module and back-light unit.
3. Note that polarizer is very fragile and could be easily damaged. Do not press or scratch the surface.
4. Do not allow drops of water or chemicals to remain on the display surface. If you have the droplets for a long time, staining and discoloration may occur.
5. If the surface of the polarizer is dirty, clean it using some absorbent cotton or soft cloth.
6. The desirable cleaners are water, IPA (Isopropyl Alcohol) or Hexane. Do not use ketene type materials (ex. Acetone), Ethyl alcohol, Toluene, Ethyl acid or Methyl chloride. It might permanent damage to the polarizer due to chemical reaction.
7. If the liquid crystal material leaks from the panel, it should be kept away from the eyes or mouth. In case of contact with hands, legs, or clothes, it must be washed away thoroughly with soap.
8. Protect the module from static, it may cause damage to the CMOS ICs.
9. Use finger-stalls with soft gloves in order to keep display clean during the incoming inspection and assembly process.
10. Do not disassemble the module.
11. Protection film for polarizer on the module shall be slowly peeled off just before use so that the electrostatic charge can be minimized.
12. Pins of I/F connector shall not be touched directly with bare hands.
13. Do not connect, disconnect the module in the "Power ON" condition.
14. Power supply should always be turned on/off by the item Power On Sequence & Power Off Sequence.

6.2 Storage and Transportation

1. Do not leave the panel in high temperature, and high humidity for a long time. It is highly recommended to store the module with temperature from 0 to 35 °C and relative humidity of less than 70%
2. Do not store the OLED module in direct sunlight.
3. The module shall be stored in a dark place. When storing the modules for a long time, be sure to adopt effective measures for protecting the modules from strong ultraviolet radiation, sunlight, or fluorescent light.
4. It is recommended that the modules should be stored under a condition where no condensation is allowed. Formation of dewdrops may cause an abnormal operation or a failure of the module. In particular, the greatest possible care should be taken to prevent any module from being operated where condensation has occurred inside.
5. This panel has its circuitry FPC on the bottom side and should be handled carefully in order not to be stressed.