

4

3

2

1

THIS DRAWING IS UNPUBLISHED. RELEASED FOR PUBLICATION
 © COPYRIGHT - By TYCO ELECTRONICS CORPORATION. ALL RIGHTS RESERVED.

LOC	DIST	REVISIONS			
P	LTR	DESCRIPTION	DATE	DWN	APVD
AF	50				
	C	REVISE PER ECR-13-013738	15FEB2014	GRZ	JL

1 CONTINUOUS STRIP ON REELS.

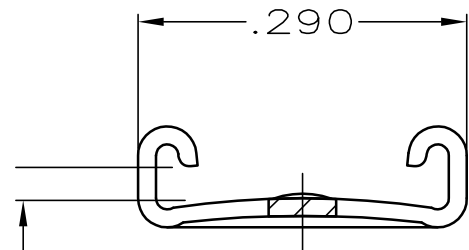
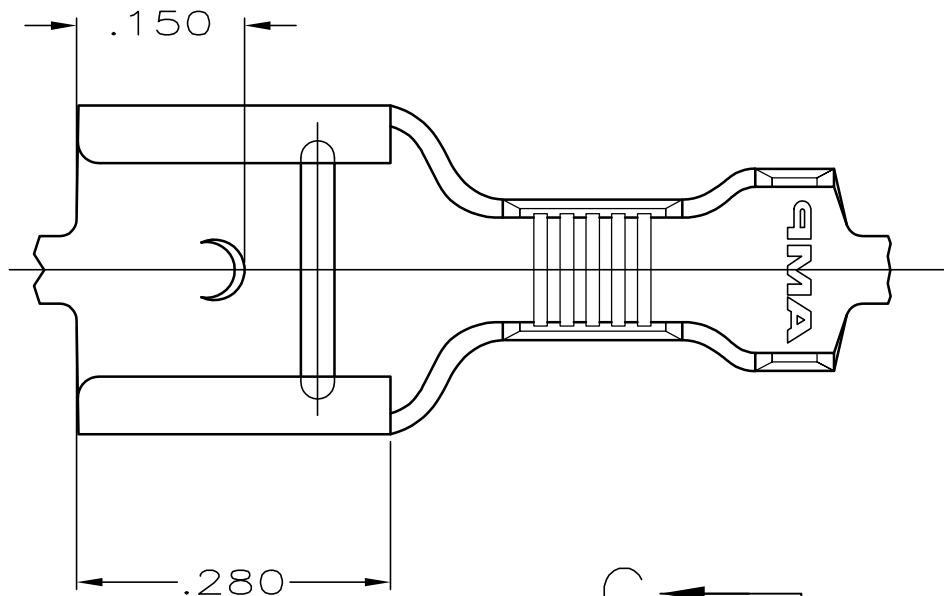

— FITS .250 SERIES FASTON TAB
 VIEW A-A

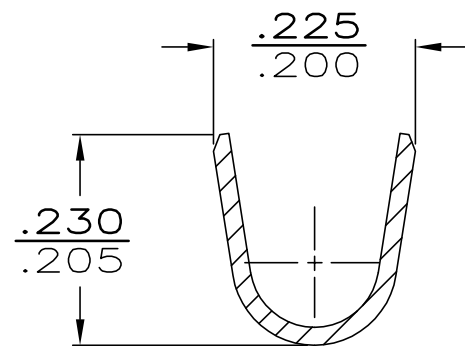
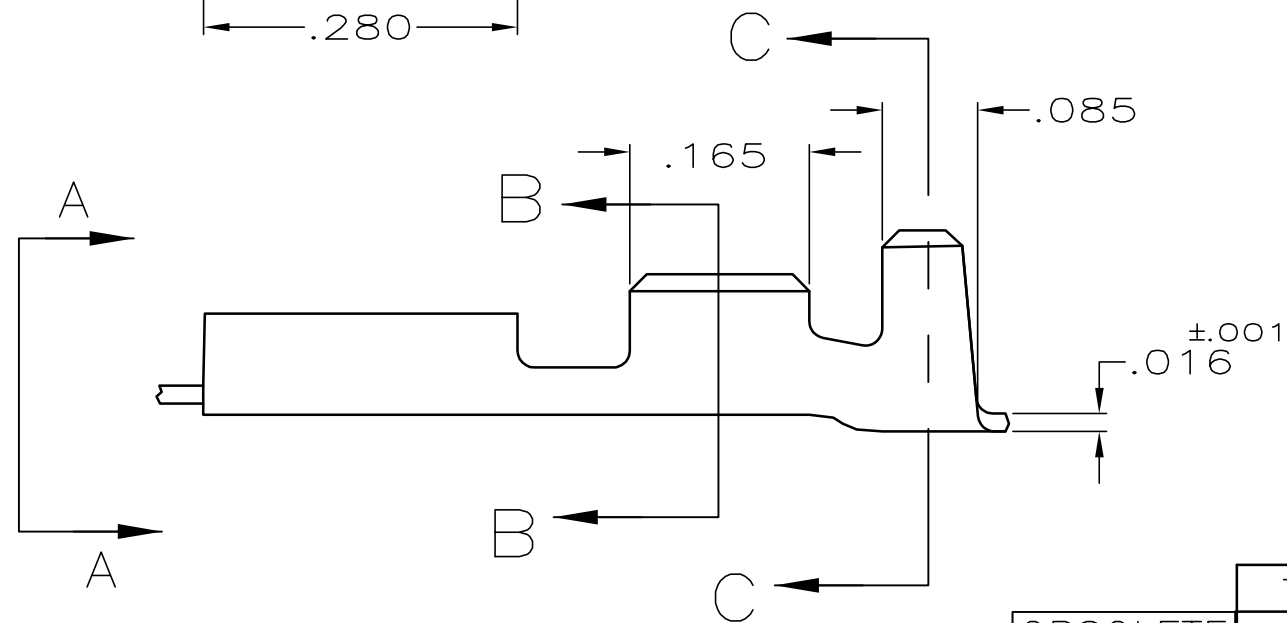

SECTION C-C

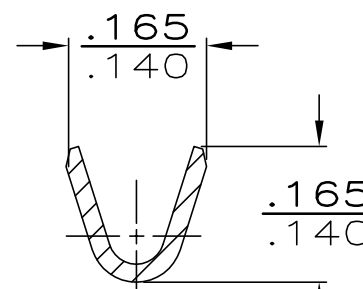

SECTION B-B

OBSOLETE	TIN	.120-.170	2000-4500	18-14 OR TWO #17's	.032	60385-2
		.120-.170	2000-4500	18-14 OR TWO #17's		60385-1
FINISH	INSULATION RANGE	CMA	MAGNET WIRE		MATING TAB THK ±.001	PART NUMBER

THIS DRAWING IS A CONTROLLED DOCUMENT.		DWN JR RUTH 5/18/90	TE TE Connectivity			
		CHK MS FEHER 5/18/90				
DIMENSIONS: INCHES	TOLERANCES UNLESS OTHERWISE SPECIFIED:	APVD C MEYERS 5/18/90	RECEPTACLE, FASTON, AMPLIVAR, .250 SERIES			
	0 PLC ± - 1 PLC ± - 2 PLC ± - 3 PLC ± .015 4 PLC ± - ANGLES ± -	PRODUCT SPEC R KUZO 5/18/90				
MATERIAL BRASS	FINISH SEE TABLE	APPLICATION SPEC	SIZE A3	CAGE CODE 00779	DRAWING NO C-60385	RESTRICTED TO
CUSTOMER DRAWING			SCALE 6:1	SHEET 1 OF 1	REV C	