

45 W high efficiency adapter evaluation board

featuring 700 V CoolMOS™ P7 in
SOT-223 package

DEMO_45W_19V_FLYB_P7

[Jared Huntington \(IFAT PMM ACDC AE\)](#)

[Florian Zechner \(IFAT PMM ACDC AE\)](#)

GD10000490



Table of contents

1

General description

2

Efficiency results

3

EMI results

Table of contents

1

General description

2

Efficiency results

3

EMI results

General description

Introduction

This evaluation board (DEMO_45W_19V_FLYB_P7) was designed in a 45 W notebook adapter form factor using the 700 V CoolMOS™ P7 in a SOT-223 package (IPN70R600P7S) and a standard flyback PWM controller. The SOT-223 package is a cost effective one-to-one drop-in alternative to DPAK that also enables footprint reduction in some designs.

This evaluation board is not only designed to meet efficiency and thermal specifications, but has also passed the necessary conducted and radiated emissions requirements. It is an evaluation board design which meets the typical notebook adapter requirements and can be produced after verification tests.

Summary of features:

- › Input voltage: 90 – 264 V_{AC}
- › Output voltage: 19 V_{DC}
- › Output current max.: 2.37 A
- › Efficiency: ~87.9% (at 115 V_{AC}, 100% load)
- › Efficiency: ~89.1% (at 230 V_{AC}, 100% load)

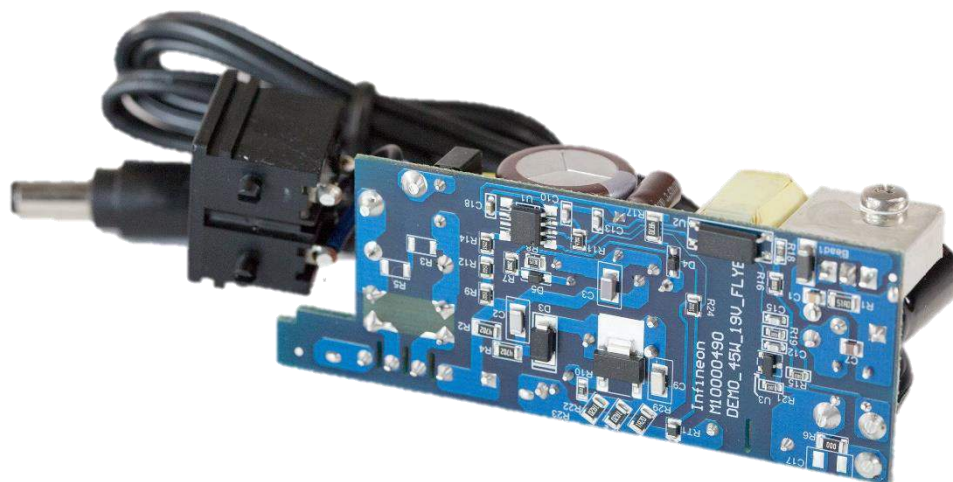

General description

Schematic

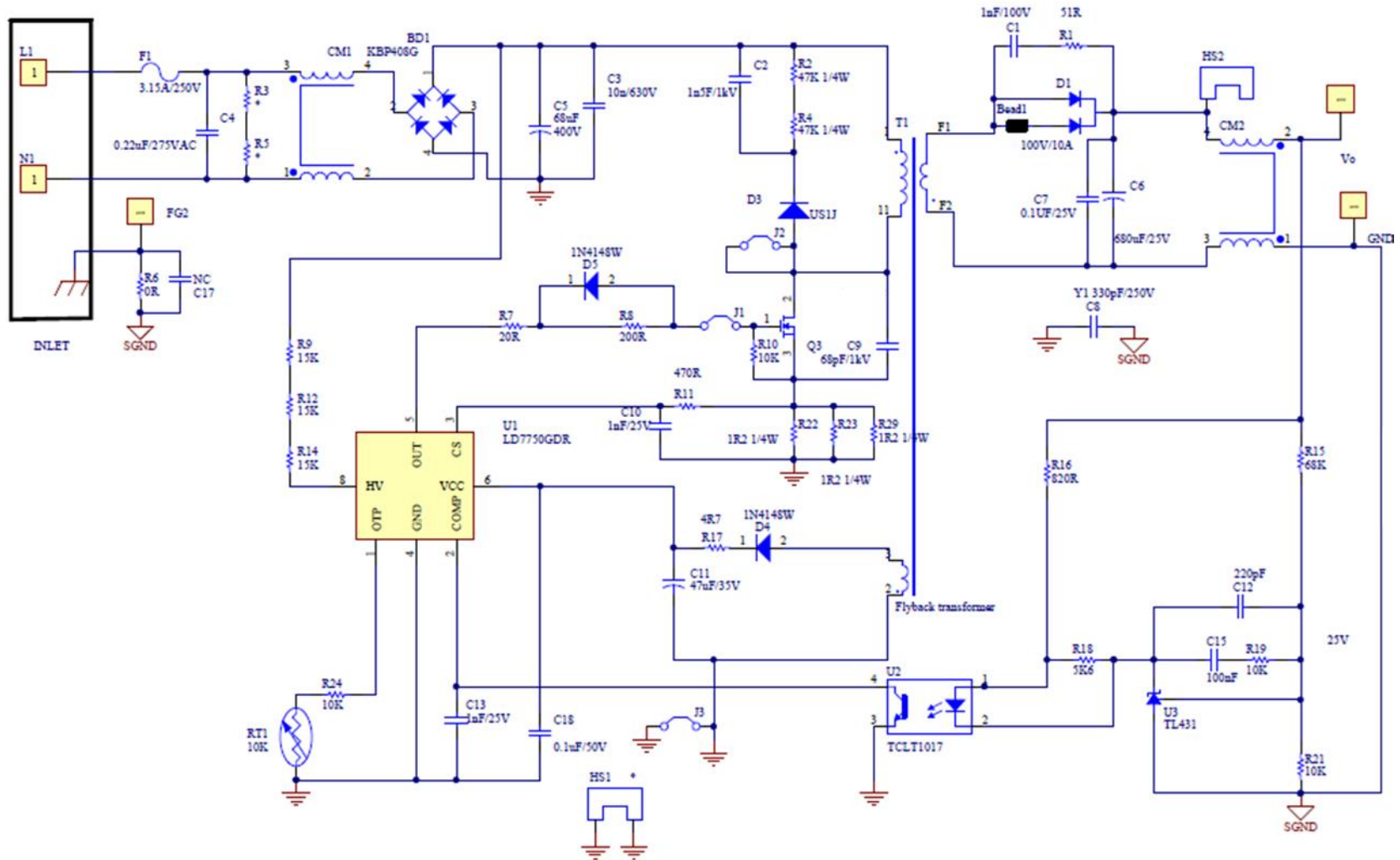

Table of contents

1

General description

2

Efficiency results

3

EMI results

Efficiency results

The table below shows the measured efficiency results of the final reference board meeting the EU CoC Version 6 requirements.

Input voltage	Rated power	P_{in}	V_{out}	I_{out}	P_{out}	Efficiency	Average η
115 V AC	25%	12.93	19.32	0.592	11.45	88.53%	88.53%
	50%	25.72	19.25	1.186	22.84	88.82%	
	75%	38.43	19.2	1.773	34.05	88.62%	
	100%	51.68	19.13	2.375	45.44	87.95%	
Input voltage	Rated power	P_{in}	V_{out}	I_{out}	P_{out}	Efficiency	Average η
230 V AC	25%	12.97	19.32	0.592	11.45	88.23%	88.79%
	50%	25.71	19.25	1.185	22.83	88.82%	
	75%	38.25	19.19	1.771	34.00	88.91%	
	100%	50.96	19.13	2.375	45.44	89.19%	

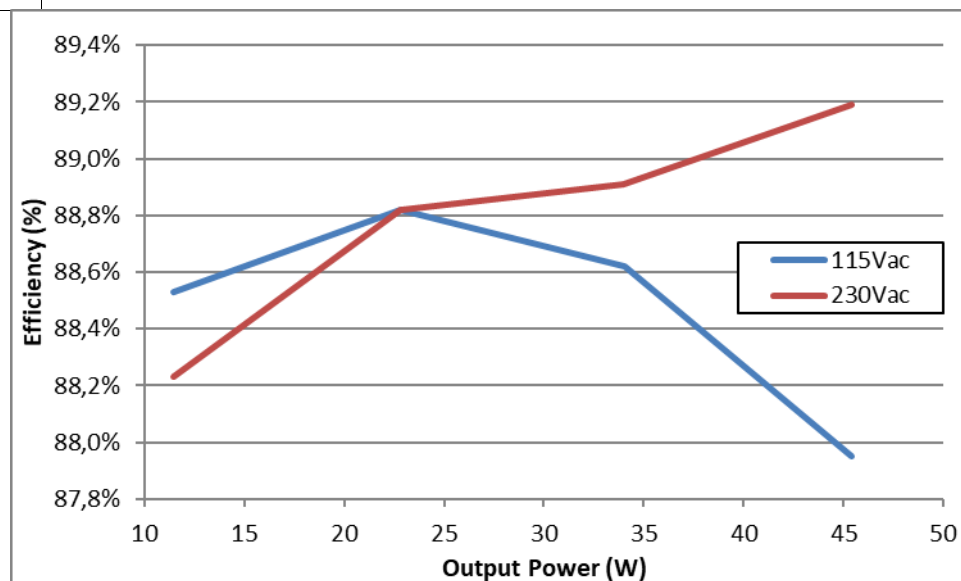

Table of contents

1

General description

2

Efficiency results

3

EMI results

Conducted EMI results

Conducted emissions results from the reference board at 115 V_{AC} (line)

Below are the conducted emissions test results. The results are tested to the EN 55022 class B limit. With the changes mentioned in the previous sections, the reference design is capable of meeting the requirements with the QP measurement 9.94 dB below the QP limit line.

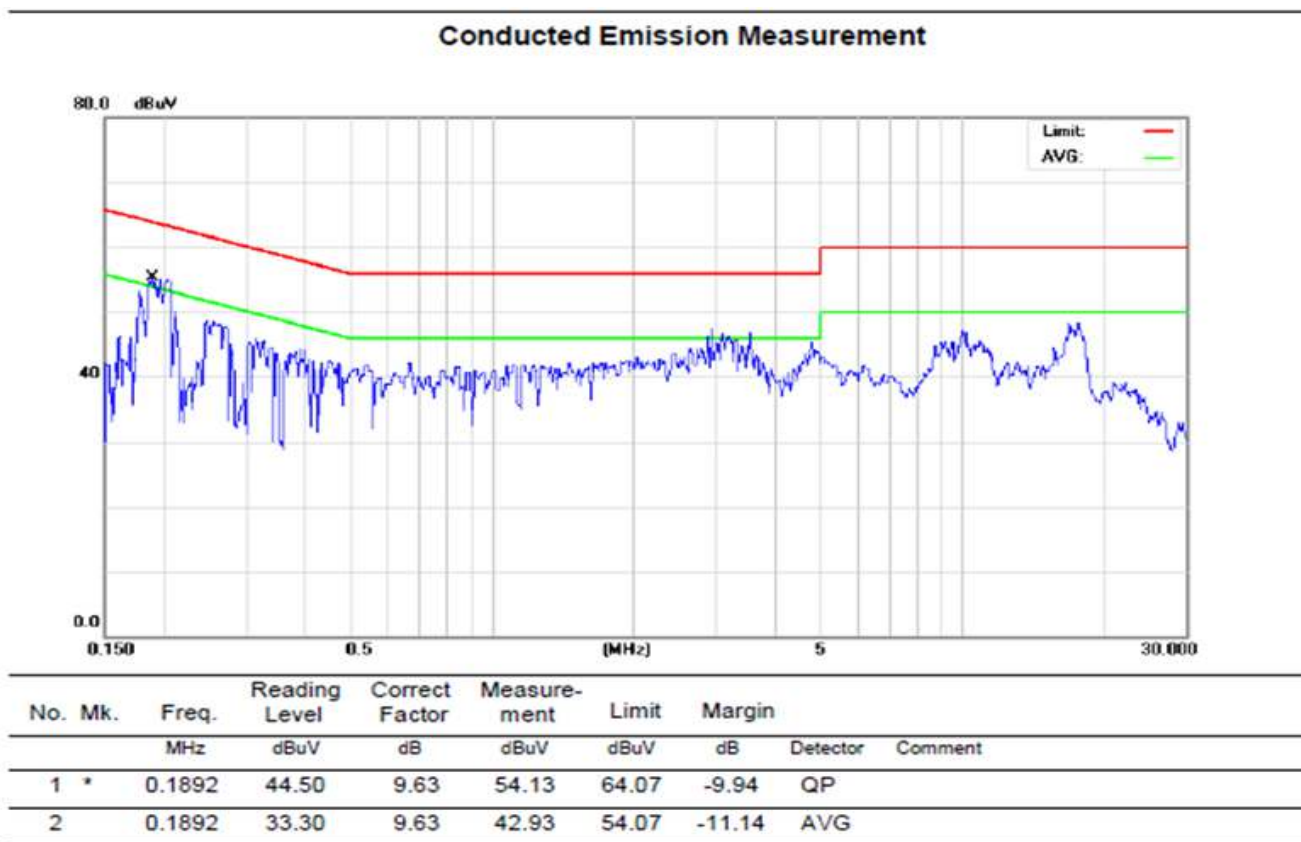

Conducted EMI results

Conducted emissions results from the reference board at 230 V_{AC} (line)

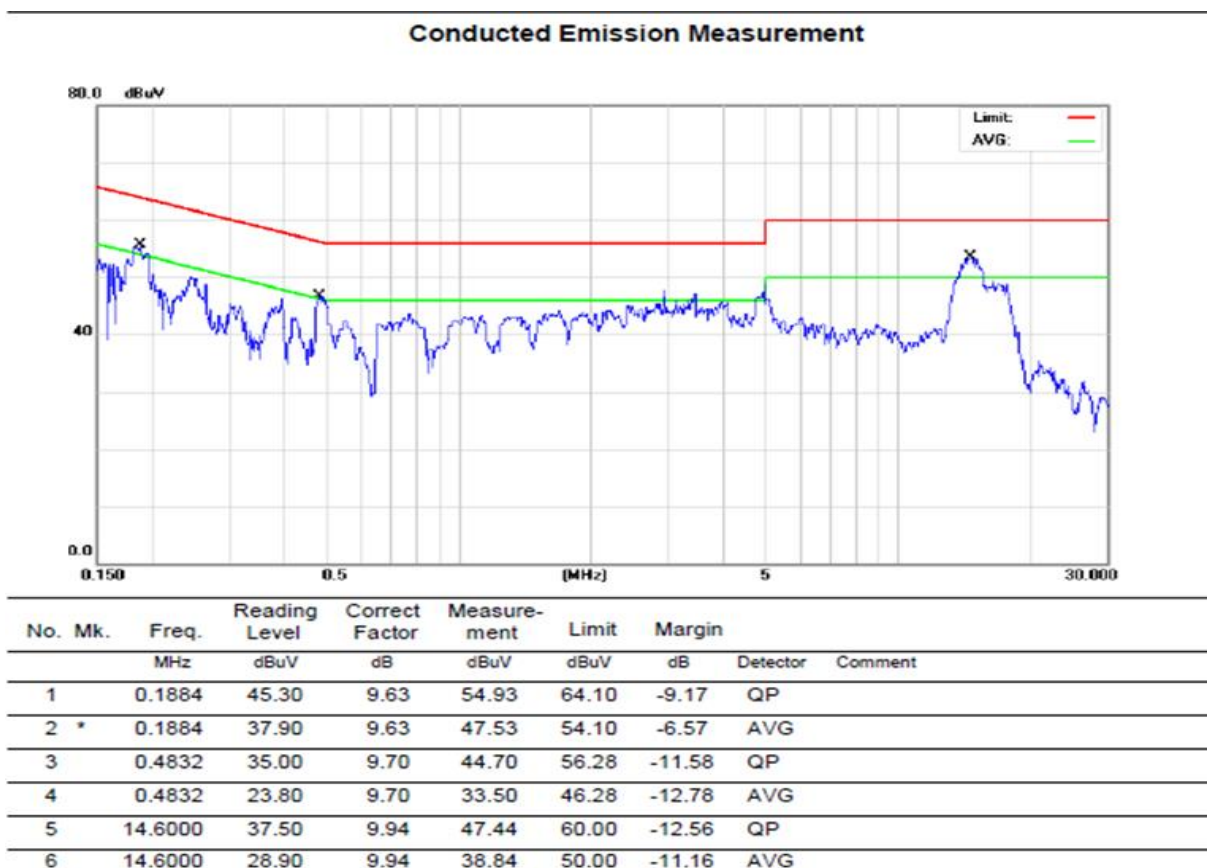

Radiated EMI results

Radiated emissions results from the reference board at 115 V_{AC} (vertical)

Below are the radiated emissions test results done in at an external EMI chamber. The results are tested to the EN 55022 class B limit. With the changes mentioned in the previous sections, the reference design is capable of meeting the requirements with the QP measurement 7.32 dB below the QP limit line.

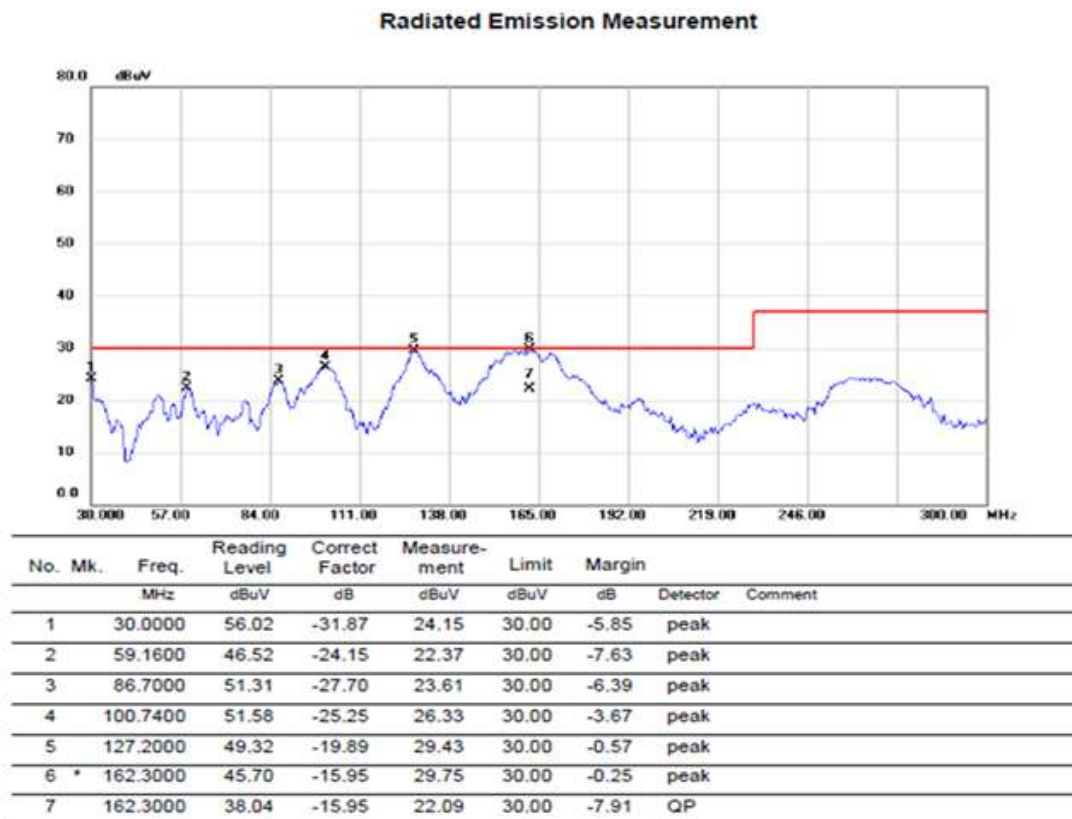

Radiated EMI results

Radiated emissions results from the reference board at 230 V_{AC} (vertical)

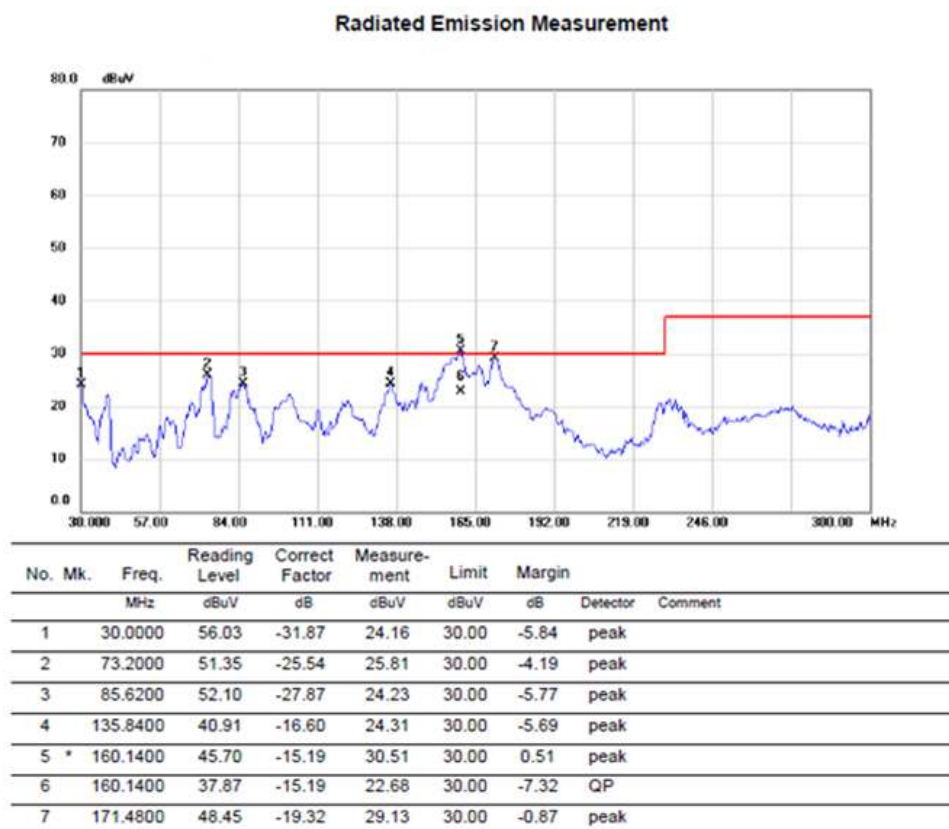



Technical Material

- > Application Notes
- > Simulation Models
- > Datasheets
- > PCB Design Data

- > [DEMO 45W 19V FLYB P7](#)
- > [IPN70R600P7S](#)

Evaluation Boards

- > Evaluation Boards
- > Demoboards
- > Reference Designs

- > www.infineon.com/evaluationboards

Videos

- > Technical Videos
- > Product Information Videos

- > www.infineon.com/mediacenter

Support

Online tools and services



The screenshot shows the Infineon website header with the following navigation links: **Products**, **Applications**, **Tools** (highlighted with a red box and a '3' in a circle), **About Infineon**, and **Careers**. On the right side of the header, there are links for **Newsletter** (highlighted with a red box and a '1' in a circle), **Contact**, **Where to Buy** (highlighted with a red box and a '2' in a circle), **English**, and **Login**. A search bar is also present. The main content area features a 'Lighting' banner with a city skyline at night. The banner text includes: 'New LED controller enables low-wattage luminaire designs August 26th 17:00 CEST' and a 'Register Now!' button. Navigation arrows are visible on the left and right sides of the banner.

- 1 **Subscribe to Newsletter**
- 2 **Where to Buy**
- 3 **Tools, Finders and Selectors**
- 4 **Support**

- **Products**
 - Applications
 - **Tools**
 - **Support** (highlighted with a red box and a '4' in a circle)
 - Technology
-
- **Power**
 - Automotive System IC
 - ESD & EMI
 - Microcontroller
 - RF & Wireless Control
 - Security IC
 - Sensor
 - Smart Card IC
 - Interface
 - Transistor & Diode
-
- **Power Overview**
 - Power MOSFET
 - IGBT
 - Smart Low-Side & High-Side Switches
 - Linear Voltage Regulator
 - DC-DC Converter
 - LED Driver | Lighting ICs
 - Silicon Carbide (SiC)
 - High Power Thyristors & Diodes
 - Motor Control & Gate Driver
 - AC-DC Supply

News & Tweets



Part of your life. Part of tomorrow.

