

# TRF1115EVM

## Contents

1	Introduction .....	1
2	EVM Test Configuration .....	2
3	Basic Test Procedure .....	3
4	Optional Configurations .....	5
5	Physical Description .....	5

## List of Figures

1	System Block Diagram.....	2
2	Test Setup Block Diagram.....	2
3	TRF1115EVM Performance.....	4
4	TRF1115 NF Performance .....	4
5	Top Layer 1.....	6
6	Ground Plane Layer 2.....	7
7	Power Plane Layer 3.....	8
8	Bottom Layer 4.....	9

## List of Tables

1	TRF1115EVM Parts List.....	9
---	----------------------------	---

## 1 Introduction

### 1.1 Overview

This is the user's guide for the TRF1115 evaluation module ( EVM). The TRF1115 is a receive LNA and down-converter with integrated amplifiers and AGC for use in a WiMAX system. The TRF1115 operates in the 2.3-GHz to 2.7-GHz band.

## 1.2 System Block Diagram

The basic radio system block diagram in [Figure 1](#) demonstrates where the TRF1115 fits in the overall transceiver. The dashed lines indicate the TRF1115 device.

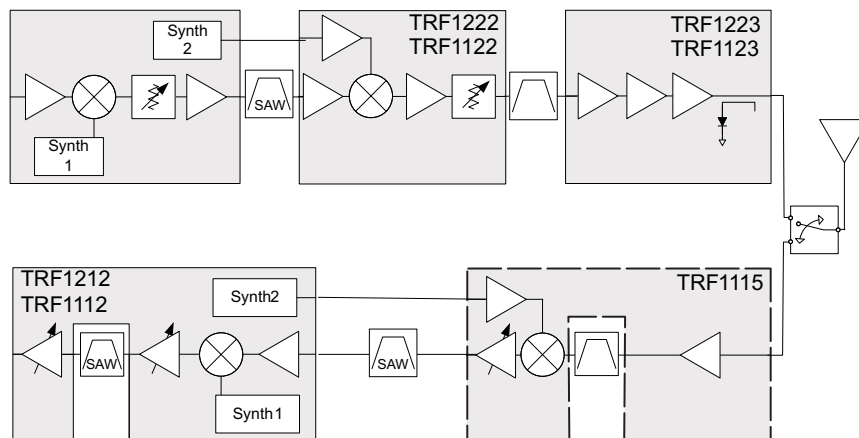
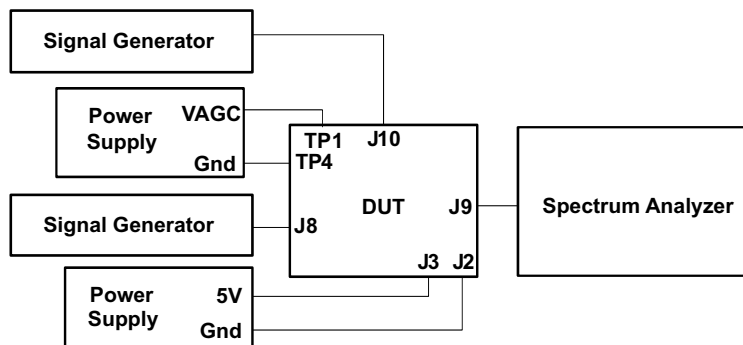

**Figure 1. System Block Diagram**

## 2 EVM Test Configuration

### 2.1 Test Block Diagram

The test setup for general testing of the TRF1115 is shown in [Figure 2](#).



**Figure 2. Test Setup Block Diagram**

### 2.2 Test Equipment

The following equipment is required for completing RF testing:

- Power supply with current readout (x2)      Agilent E3631 or equivalent
- Signal generator for input signal      Agilent E4438C or equivalent
- Signal generator for LO source      Agilent E4438C or equivalent
- Spectrum analyzer      Agilent E4440A or equivalent

## 2.3 Calibration

The output RF cable and input LO cable should be good-quality RF cables due to the high-frequency signals.

- Measure the insertion loss of the RF input cable at the frequency of operation. Compensate for the loss of this cable by incrementing the amplitude of the signal generator over the desired value by the amount of insertion loss. For example, if the insertion loss of the cable is 1.5 dB and the desired set point is  $-45$  dBm, the amplitude of the generator should be set to  $-43.5$  dB.
- Measure the insertion loss of the RF cable used to inject the LO signal at the frequency of operation. Compensate for the loss of this cable by incrementing the amplitude of the signal generator over the desired value by the amount of insertion loss. For example, if the insertion loss of the cable is 1.2 dB and the desired set point is 0 dBm, the amplitude of the generator should be set to 1.2 dB.
- Measure the insertion loss of the IF out cable at its frequency of operation. Compensate for the loss of this cable by adjusting the reference level offset in the spectrum analyzer.

## 3 Basic Test Procedure

This section outlines the basic test procedure for testing the EVM. The last section is not required for basic functionality but is included for reference.

### 3.1 Initial Inspection

- Verify that the jumper connection at J6 is at the *Ext* location.

### 3.2 DC Test

- Connect +5 V to J3; connect ground to J2.
- Engage power supplies.
- Verify that current on is  $175 \pm 25$  mA

### 3.3 Basic RF Test

- Inject 2400-MHz CW signal in at J8 at  $-45$  dBm; ensure that the RF output cable loss is compensated for.
- Connect spectrum analyzer at J9.
- Set spectrum analyzer center frequency to 456 MHz.
- Connect second power supply for AGC control to TP1: *AGCExt* and set to 1.5 V; ground can be connected at J2 or at TP4.
- Connect second signal generator at J10 and set to 0 dBm at frequency: 1944 MHz; ensure that LO cable loss is compensated for.
- Adjust AGC control for minimum gain by adjusting AGC voltage to 1.5 V.
- Measure signal at 456 MHz, and verify signal at  $-40$  dBm  $\pm 3$  dB.
- Adjust AGC control for maximum gain by adjusting AGC voltage to 0 V.
- Measure signal at 456 MHz, and verify signal at  $-30$  dBm  $\pm 3$  dB.

### 3.4 Modulated RF Performance

- Inject 3400-MHz modulated signal in at J8 at  $-45$  dBm.
- Set AGC voltage to 0 V for maximum gain.
- Inject CW LO source at J10, and set to 0 dBm at frequency 1944 MHz. Note, this should be a low-phase noise source. Verify LO cable loss is compensated for.
- Connect cable to spectrum analyzer at J9, and initiate WiMAX analysis program.
- Set spectrum analyzer center frequency to 456 MHz.
- Adjust reference level offset to appropriate range for output signal.
- Verify that output signal power is at  $-28 \pm 2$  dBm; ensure RF output cable loss is compensated for.

- Verify that EVM performance is less than  $-40$  dB; see [Figure 3](#).

### 3.5 NF Performance

The noise figure of the evaluation board measured using a noise diode under maximum gain settings over frequency is shown in [Figure 4](#).

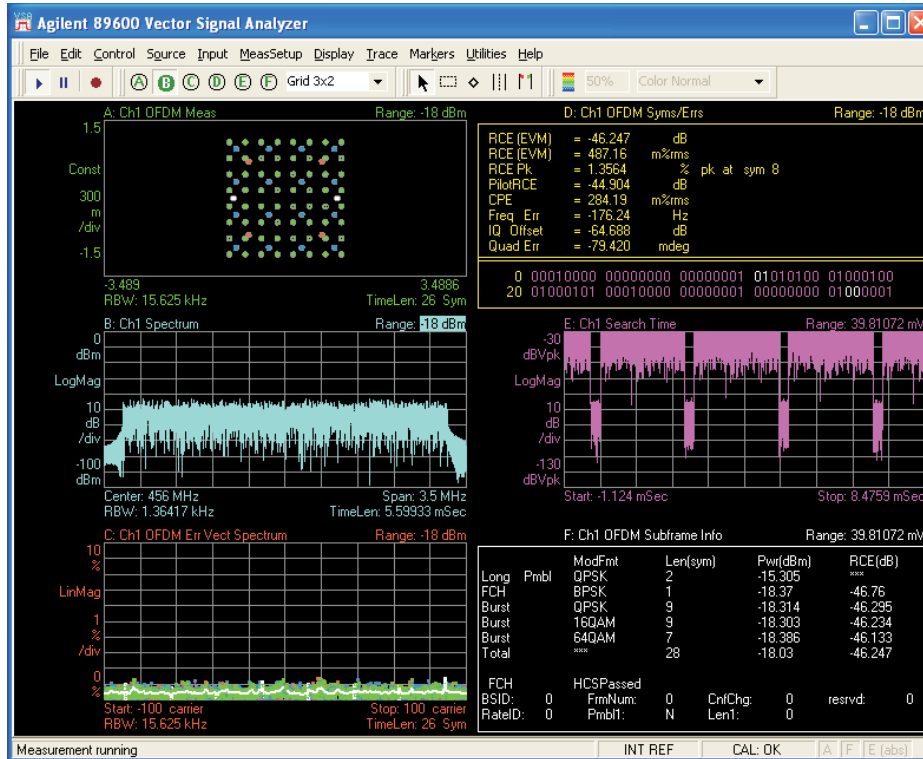

Figure 3. TRF1115EVM Performance

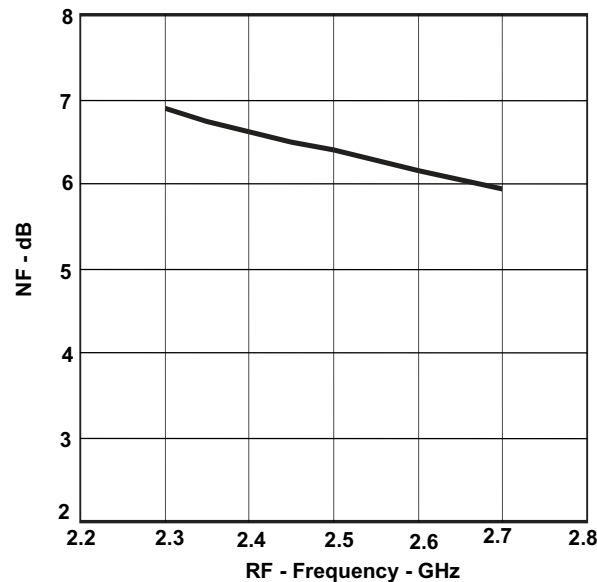

Figure 4. TRF1115 NF Performance

## 4 Optional Configurations

### 4.1 External RF Filter

The EVM is configured with the LNA output directly connected to the mixer input. These ports are intended to provide an option for an RF filter at this location. An external filter can be used by installing the jumpers to route the signal to SMA connectors. Note, this option also facilitates monitoring the LNA portion independent of the rest of the chip. To employ this option, the following modifications are required.

- Move R19 to R16 location.
- Move R8 to R18 location.
- Monitor at connectors J4 (LNA output) and J1 (mixer input).

### 4.2 Differential Inputs

The normal configuration uses transformers and baluns to convert the differential signals to single ended to facilitate laboratory testing. If desired, any of the inputs can be converted to differential operation, which may be desirable when cascading one or more of the chipset's EVMs together.

#### 4.2.1 IF Output

- Remove T1.
- Place R14: 0- $\Omega$  resistor (1210).
- Place R10: 0- $\Omega$  resistor.
- Differential outputs at J9 and J7.

#### 4.2.2 LO Input

- Remove T2.
- Jumper across pads of T2 (input to output on each side) using a 0- $\Omega$  0201 resistor.
- Place 4.7-pF capacitor at R15.
- Differential inputs at J10 and J11.

### 4.3 Internal AGC Control

The AGC control can be driven internally by adjusting the resistor potentiometer at R1. To employ this option, move the jumper at J6 to *Int*, and adjust the AGC voltage by tuning the potentiometer at R1 between 0 V and 1.5 V.

## 5 Physical Description

This section describes the physical characteristics and PCB layout of the EVM and lists the components used on the module.

## 5.1 PCB Layout

The EVM is constructed on a 4-layer, 2.5-inch × 2.5-inch, 0.062-inch thick PCB using FR4-170 material. Figure 5 through Figure 8 show the PCB layout for the EVM.

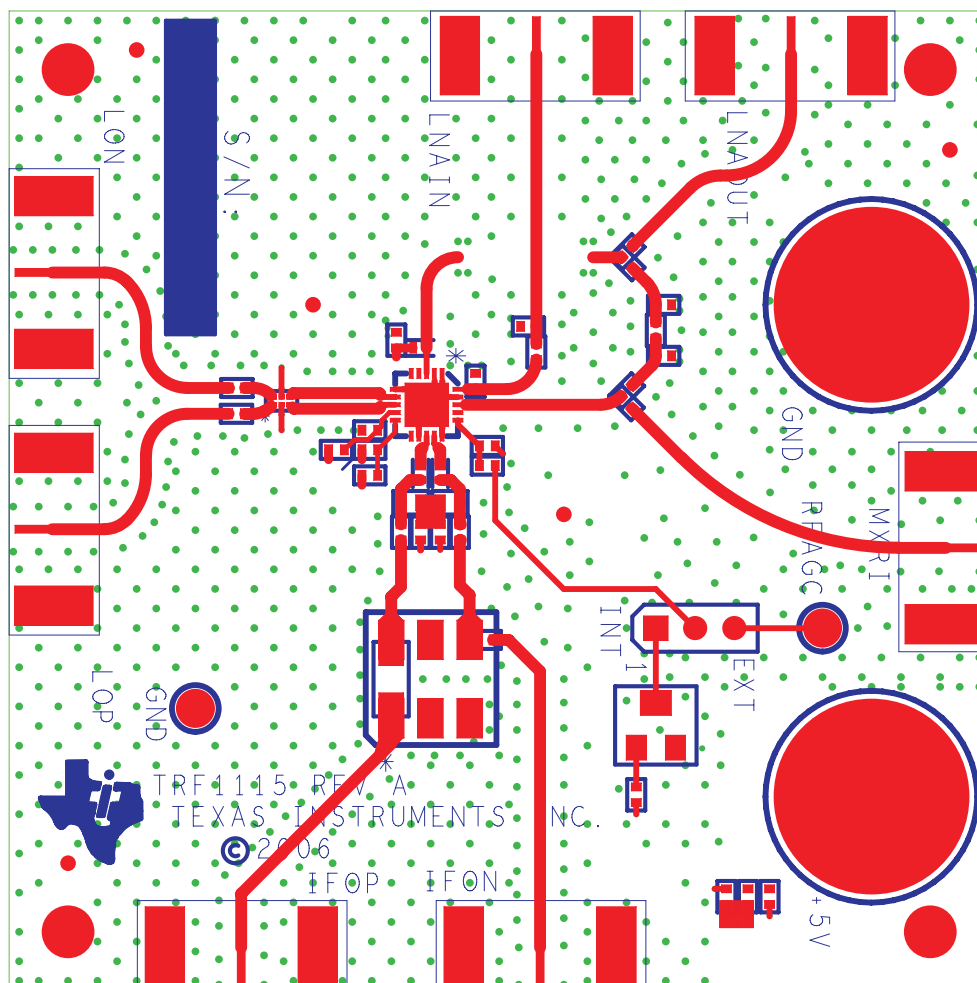
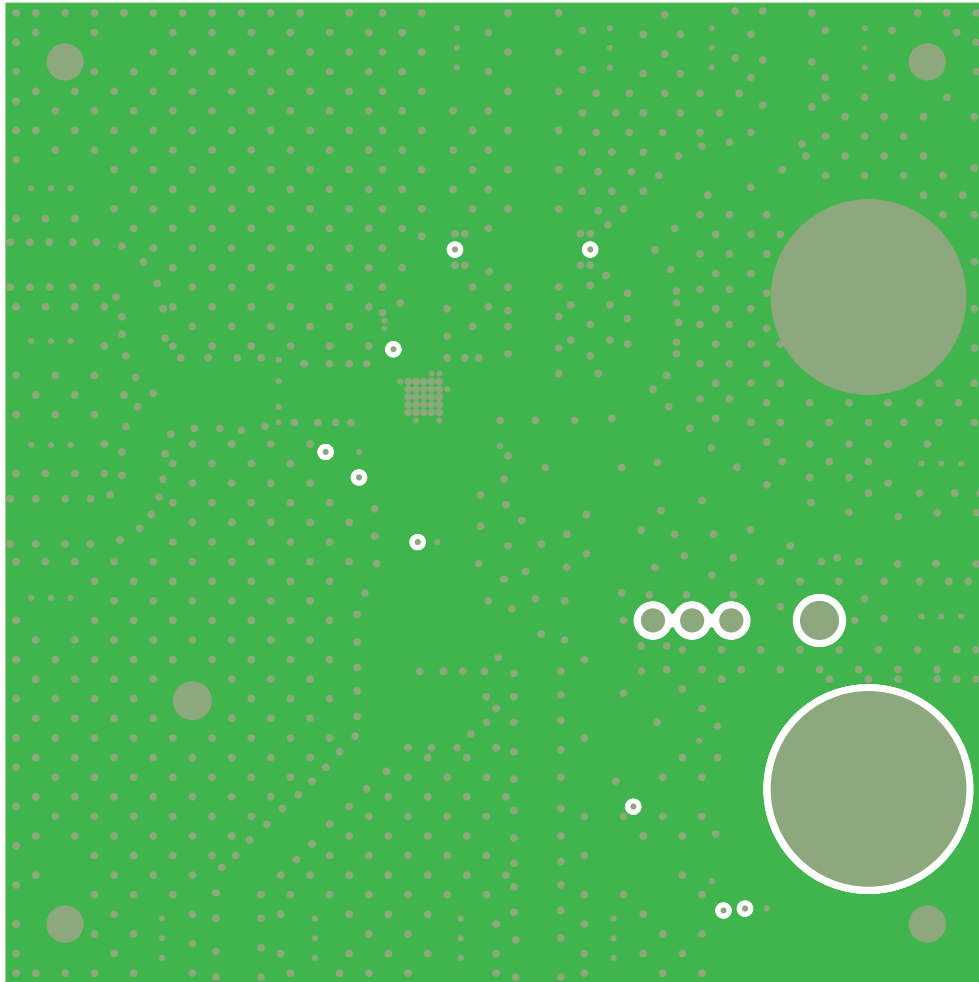
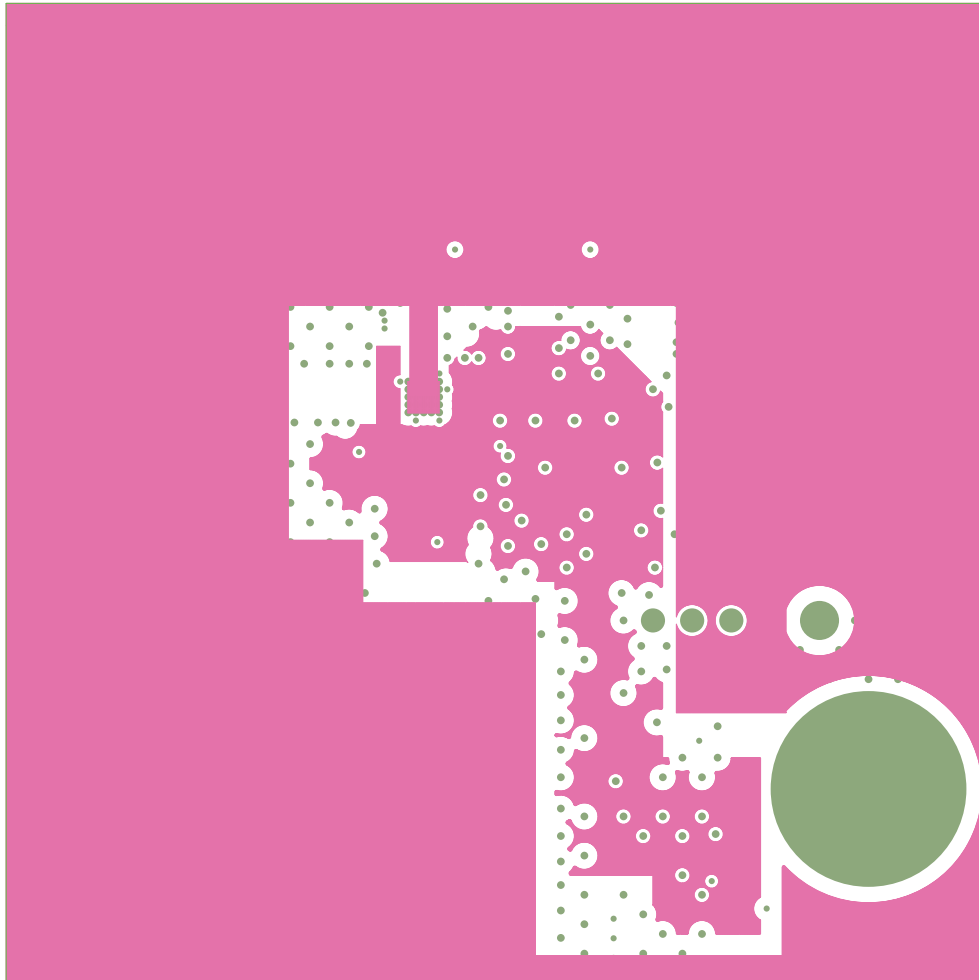

Figure 5. Top Layer 1



**Figure 6. Ground Plane Layer 2**



**Figure 7. Power Plane Layer 3**



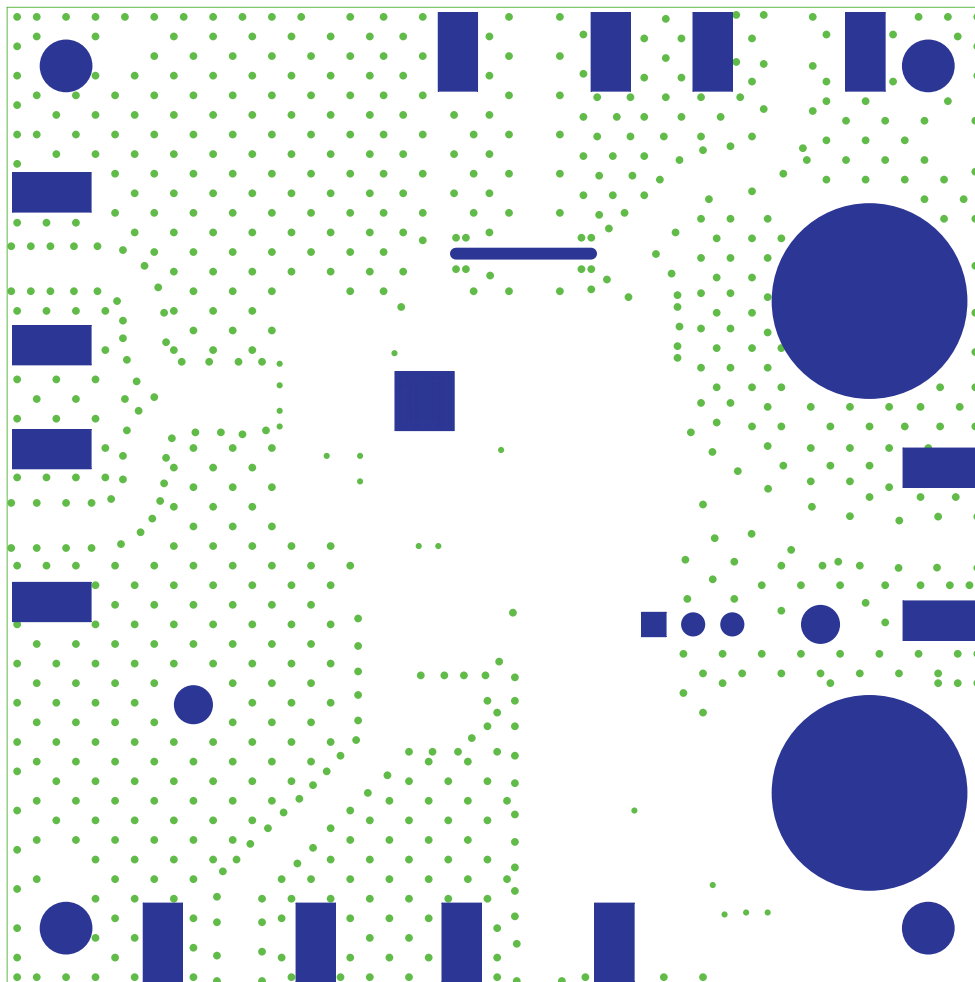

Figure 8. Bottom Layer 4

## 5.2 Parts List

Table 1 lists the parts used in constructing the EVM.

Table 1. TRF1115EVM Parts List

Qty	Reference	Value	Mfr Name	Part Number	Note
2	C1 C2	1 $\mu$ F	Panasonic	ECJ-0EB1A105M	
4	C5 C22–C24	4.7pF	Murata	GRM1555C1H4R7CZ01D	
1	C7	220pF	Murata	GRM1555C1H221JA01D	
2	C8 C9	100pF	AVX	0402A101JAT2A	
1	C55	20pF	Murata	GRM1555C1H200JZ01D	
5	FB1 FB2 FB4 FB5 FB6	120	Murata	BLM15AG121SNIB	
7	J1 J4 J7 J8 J9 J10 J11	SMA_END_FLAT	Johnson Components	142-0701-851	
1	J2	BLK	Allied Electronics	ST-351B	
1	J3	RED	Allied Electronics	ST-351A	
1	J6	Header_1x3_100	SAMTEC	TSW-103-07-L-S	
2	L1 L4	220nH	Coilcraft	0603CS-R33XJLU	
2	L2 L3	18nH	Coilcraft	0402CS-18NXKLU	

**Table 1. TRF1115EVM Parts List (continued)**

Qty	Reference	Value	Mfr Name	Part Number	Note
1	L15	22nH	Coilcraft	0402CS-22NXJL	
4	MT1 MT2 MT3 MT4	STANDOFF	Keystone	3480	STANDOFF
1	R1	10K	Bourns	3214W-1-103E	
1	R2	8.25K	Panasonic	ERJ-2RKF8251X	
3	R8 R12 R16	0	Panasonic	ERJ-2GE0R00X	
0	R10 R11 R13 R15 R18 R19	0	Panasonic	ERJ-2GE0R00X	DNI
0	R14	0	Panasonic	ERJ-8GEY0R00V	DNI
1	R55	18	Panasonic	ERJ-2GEJ180X	
2	R65 R66	300	Panasonic	ERJ-2GEJ301X	
1	T1	JTX-2-10T	Minicircuits	JTX-2-10T	
1	T2	2326MHz	Anaren	BD2326L50100A00	
1	TP1	Red	Keystone	5000	
1	TP4	Blk	Keystone	5001	
1	U1	TRF1115	TI	TRF1115	

### 5.3 Schematic

The TRF1115EVM schematic appears on the following page.

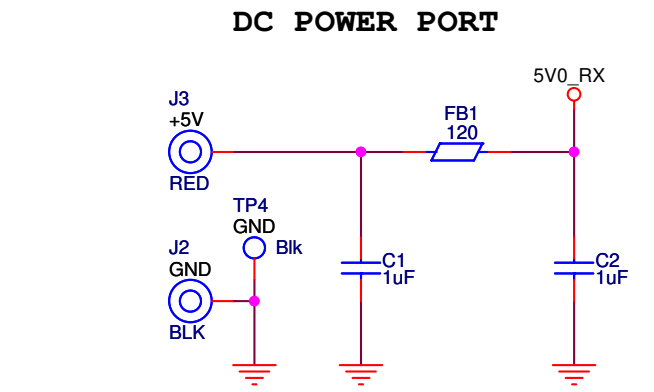
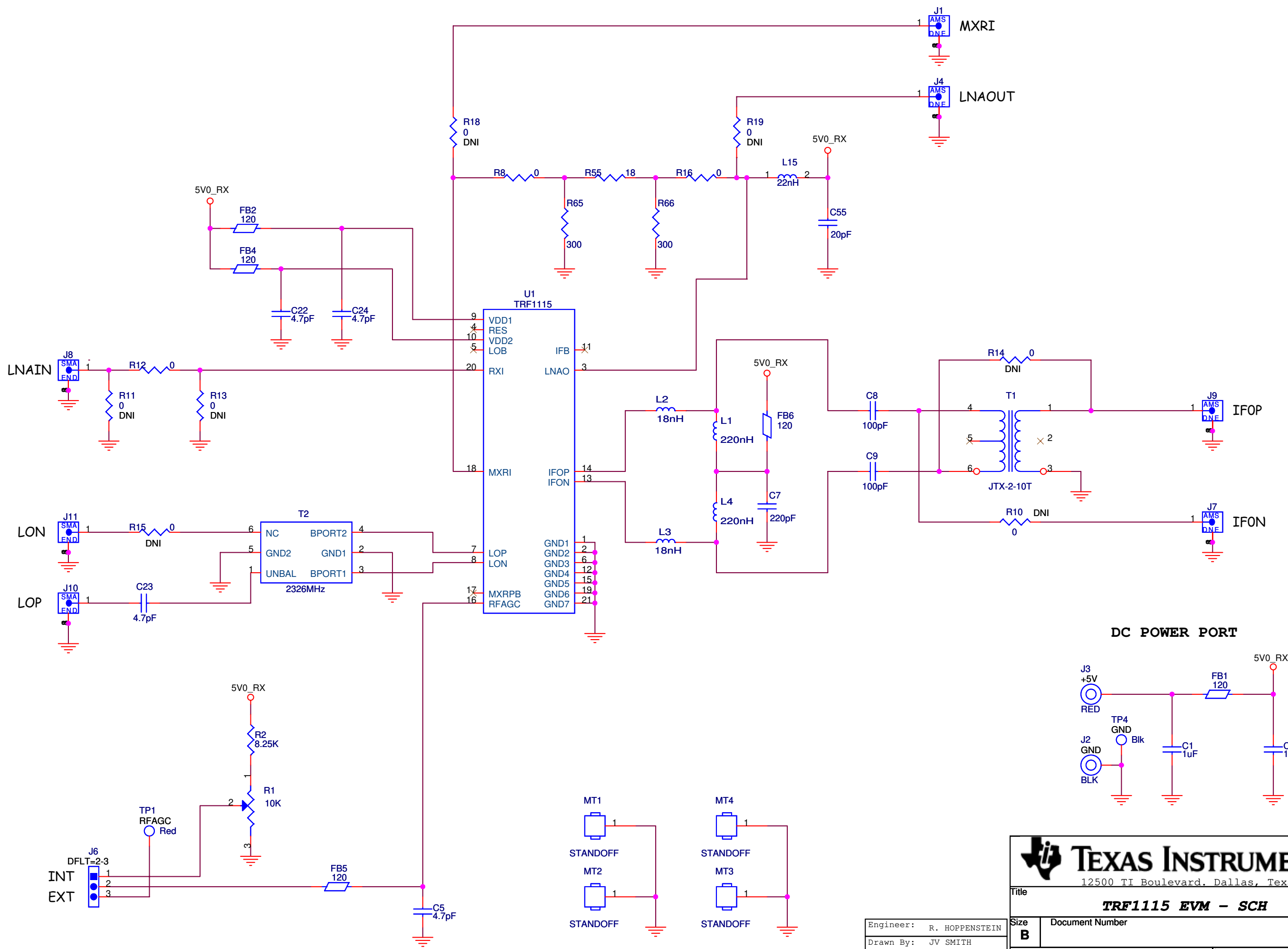

**TEXAS INSTRUMENTS**  
 12500 TI Boulevard, Dallas, Texas 75243

**TRF1115 EVM - SCH**

Engineer: R. HOPPENSTEIN	Document Number	Rev A
Drawn By: JV SMITH	Date: Thursday, August 03, 2006	Sheet 1 of 1

Engineer: R. HOPPENSTEIN  
 Drawn By: JV SMITH

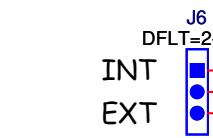
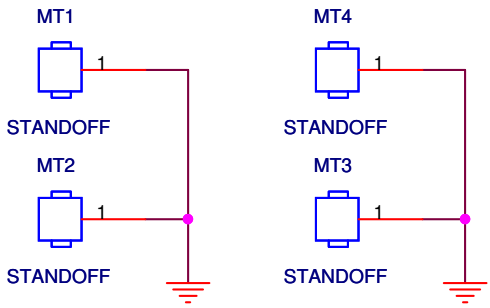

## EVALUATION BOARD/KIT IMPORTANT NOTICE

Texas Instruments (TI) provides the enclosed product(s) under the following conditions:

This evaluation board/kit is intended for use for **ENGINEERING DEVELOPMENT, DEMONSTRATION, OR EVALUATION PURPOSES ONLY** and is not considered by TI to be a finished end-product fit for general consumer use. Persons handling the product(s) must have electronics training and observe good engineering practice standards. As such, the goods being provided are not intended to be complete in terms of required design-, marketing-, and/or manufacturing-related protective considerations, including product safety and environmental measures typically found in end products that incorporate such semiconductor components or circuit boards. This evaluation board/kit does not fall within the scope of the European Union directives regarding electromagnetic compatibility, restricted substances (RoHS), recycling (WEEE), FCC, CE or UL, and therefore may not meet the technical requirements of these directives or other related directives.

Should this evaluation board/kit not meet the specifications indicated in the User's Guide, the board/kit may be returned within 30 days from the date of delivery for a full refund. **THE FOREGOING WARRANTY IS THE EXCLUSIVE WARRANTY MADE BY SELLER TO BUYER AND IS IN LIEU OF ALL OTHER WARRANTIES, EXPRESSED, IMPLIED, OR STATUTORY, INCLUDING ANY WARRANTY OF MERCHANTABILITY OR FITNESS FOR ANY PARTICULAR PURPOSE.**

The user assumes all responsibility and liability for proper and safe handling of the goods. Further, the user indemnifies TI from all claims arising from the handling or use of the goods. Due to the open construction of the product, it is the user's responsibility to take any and all appropriate precautions with regard to electrostatic discharge.

**EXCEPT TO THE EXTENT OF THE INDEMNITY SET FORTH ABOVE, NEITHER PARTY SHALL BE LIABLE TO THE OTHER FOR ANY INDIRECT, SPECIAL, INCIDENTAL, OR CONSEQUENTIAL DAMAGES.**

TI currently deals with a variety of customers for products, and therefore our arrangement with the user **is not exclusive.**

TI assumes **no liability for applications assistance, customer product design, software performance, or infringement of patents or services described herein.**

Please read the User's Guide and, specifically, the Warnings and Restrictions notice in the User's Guide prior to handling the product. This notice contains important safety information about temperatures and voltages. For additional information on TI's environmental and/or safety programs, please contact the TI application engineer or visit [www.ti.com/esh](http://www.ti.com/esh).

No license is granted under any patent right or other intellectual property right of TI covering or relating to any machine, process, or combination in which such TI products or services might be or are used.

### FCC Warning

This evaluation board/kit is intended for use for **ENGINEERING DEVELOPMENT, DEMONSTRATION, OR EVALUATION PURPOSES ONLY** and is not considered by TI to be a finished end-product fit for general consumer use. It generates, uses, and can radiate radio frequency energy and has not been tested for compliance with the limits of computing devices pursuant to part 15 of FCC rules, which are designed to provide reasonable protection against radio frequency interference. Operation of this equipment in other environments may cause interference with radio communications, in which case the user at his own expense will be required to take whatever measures may be required to correct this interference.

### EVM WARNINGS AND RESTRICTIONS

It is important to operate this EVM within the input voltage range of 0 V to 5 V and the output voltage range of 0 V to 5 V.

Exceeding the specified input range may cause unexpected operation and/or irreversible damage to the EVM. If there are questions concerning the input range, please contact a TI field representative prior to connecting the input power.

Applying loads outside of the specified output range may result in unintended operation and/or possible permanent damage to the EVM. Please consult the EVM User's Guide prior to connecting any load to the EVM output. If there is uncertainty as to the load specification, please contact a TI field representative.

During normal operation, some circuit components may have case temperatures greater than 85°C. The EVM is designed to operate properly with certain components above 85°C as long as the input and output ranges are maintained. These components include but are not limited to linear regulators, switching transistors, pass transistors, and current sense resistors. These types of devices can be identified using the EVM schematic located in the EVM User's Guide. When placing measurement probes near these devices during operation, please be aware that these devices may be very warm to the touch.

Mailing Address: Texas Instruments, Post Office Box 655303, Dallas, Texas 75265  
Copyright © 2006, Texas Instruments Incorporated

## IMPORTANT NOTICE

Texas Instruments Incorporated and its subsidiaries (TI) reserve the right to make corrections, modifications, enhancements, improvements, and other changes to its products and services at any time and to discontinue any product or service without notice. Customers should obtain the latest relevant information before placing orders and should verify that such information is current and complete. All products are sold subject to TI's terms and conditions of sale supplied at the time of order acknowledgment.

TI warrants performance of its hardware products to the specifications applicable at the time of sale in accordance with TI's standard warranty. Testing and other quality control techniques are used to the extent TI deems necessary to support this warranty. Except where mandated by government requirements, testing of all parameters of each product is not necessarily performed.

TI assumes no liability for applications assistance or customer product design. Customers are responsible for their products and applications using TI components. To minimize the risks associated with customer products and applications, customers should provide adequate design and operating safeguards.

TI does not warrant or represent that any license, either express or implied, is granted under any TI patent right, copyright, mask work right, or other TI intellectual property right relating to any combination, machine, or process in which TI products or services are used. Information published by TI regarding third-party products or services does not constitute a license from TI to use such products or services or a warranty or endorsement thereof. Use of such information may require a license from a third party under the patents or other intellectual property of the third party, or a license from TI under the patents or other intellectual property of TI.

Reproduction of information in TI data books or data sheets is permissible only if reproduction is without alteration and is accompanied by all associated warranties, conditions, limitations, and notices. Reproduction of this information with alteration is an unfair and deceptive business practice. TI is not responsible or liable for such altered documentation.

Resale of TI products or services with statements different from or beyond the parameters stated by TI for that product or service voids all express and any implied warranties for the associated TI product or service and is an unfair and deceptive business practice. TI is not responsible or liable for any such statements.

TI products are not authorized for use in safety-critical applications (such as life support) where a failure of the TI product would reasonably be expected to cause severe personal injury or death, unless officers of the parties have executed an agreement specifically governing such use. Buyers represent that they have all necessary expertise in the safety and regulatory ramifications of their applications, and acknowledge and agree that they are solely responsible for all legal, regulatory and safety-related requirements concerning their products and any use of TI products in such safety-critical applications, notwithstanding any applications-related information or support that may be provided by TI. Further, Buyers must fully indemnify TI and its representatives against any damages arising out of the use of TI products in such safety-critical applications.

TI products are neither designed nor intended for use in military/aerospace applications or environments unless the TI products are specifically designated by TI as military-grade or "enhanced plastic." Only products designated by TI as military-grade meet military specifications. Buyers acknowledge and agree that any such use of TI products which TI has not designated as military-grade is solely at the Buyer's risk, and that they are solely responsible for compliance with all legal and regulatory requirements in connection with such use.

TI products are neither designed nor intended for use in automotive applications or environments unless the specific TI products are designated by TI as compliant with ISO/TS 16949 requirements. Buyers acknowledge and agree that, if they use any non-designated products in automotive applications, TI will not be responsible for any failure to meet such requirements.

Following are URLs where you can obtain information on other Texas Instruments products and application solutions:

<b>Products</b>		<b>Applications</b>	
Amplifiers	<a href="http://amplifier.ti.com">amplifier.ti.com</a>	Audio	<a href="http://www.ti.com/audio">www.ti.com/audio</a>
Data Converters	<a href="http://dataconverter.ti.com">dataconverter.ti.com</a>	Automotive	<a href="http://www.ti.com/automotive">www.ti.com/automotive</a>
DSP	<a href="http://dsp.ti.com">dsp.ti.com</a>	Broadband	<a href="http://www.ti.com/broadband">www.ti.com/broadband</a>
Interface	<a href="http://interface.ti.com">interface.ti.com</a>	Digital Control	<a href="http://www.ti.com/digitalcontrol">www.ti.com/digitalcontrol</a>
Logic	<a href="http://logic.ti.com">logic.ti.com</a>	Military	<a href="http://www.ti.com/military">www.ti.com/military</a>
Power Mgmt	<a href="http://power.ti.com">power.ti.com</a>	Optical Networking	<a href="http://www.ti.com/opticalnetwork">www.ti.com/opticalnetwork</a>
Microcontrollers	<a href="http://microcontroller.ti.com">microcontroller.ti.com</a>	Security	<a href="http://www.ti.com/security">www.ti.com/security</a>
RFID	<a href="http://www.ti-rfid.com">www.ti-rfid.com</a>	Telephony	<a href="http://www.ti.com/telephony">www.ti.com/telephony</a>
Low Power Wireless	<a href="http://www.ti.com/lpw">www.ti.com/lpw</a>	Video & Imaging	<a href="http://www.ti.com/video">www.ti.com/video</a>
		Wireless	<a href="http://www.ti.com/wireless">www.ti.com/wireless</a>

Mailing Address: Texas Instruments, Post Office Box 655303, Dallas, Texas 75265  
Copyright © 2007, Texas Instruments Incorporated