

LOC		DIST		REVISIONS			
GP	00	REV	DATE	BY	CHKD	APVD	
C2	REVISED PER ECO-11-004835		11MAR11	RK	HMR		

- CONNECTORS COMPLY WITH AMP SPEC. 108-40012 AND MATE WITH ANY SAME NUMBER POSITION PLUG CONNECTOR IN AMPLIMITE SERIES.
- CONNECTOR DESIGNED FOR 28 AND 26 AWG STRANDED AND SOLID CONDUCTOR RIBBON CABLE ON .050t.
- FASTENERS WILL WITHSTAND 6 IN. LBS. TORQUE AND 50 LBS PULL OUT FORCE FROM MATING FACE SIDE.
- MOLDED PARTS: UL RATED 94 V-O THERMOPLASTIC, COLOR: BLACK.
- SHELL: STEEL PER QQ-S-698.
- CONTACTS: PHOSPHOR BRONZE PER QQ-B-750.
- FASTENERS: BRASS PER QQ-B-626.
- GOLD PLATING PER MIL-G-45204, TIN PLATING PER MIL-T-10727, NICKEL PLATING PER QQ-N-290.
- SHELL: BRIGHT TIN PLATED.
- CONTACTS: PLATED WITH .000030 GOLD IN LOCALIZED GOLD PLATE AREA, .000100-.000200 MATTE TIN ON TERMINATION END, ALL OVER .000050 NICKEL ON ENTIRE CONTACT.
- LOCKING FASTENER IS COLOR CODED BLUE TO IDENTIFY SELF-LOCKING FEATURE.
- LOCKING FEATURE PROVIDES A RESISTIVE TORQUE OF 10 TO 80 IN-OZ, USING A 4-40 GAUGE SCREW.

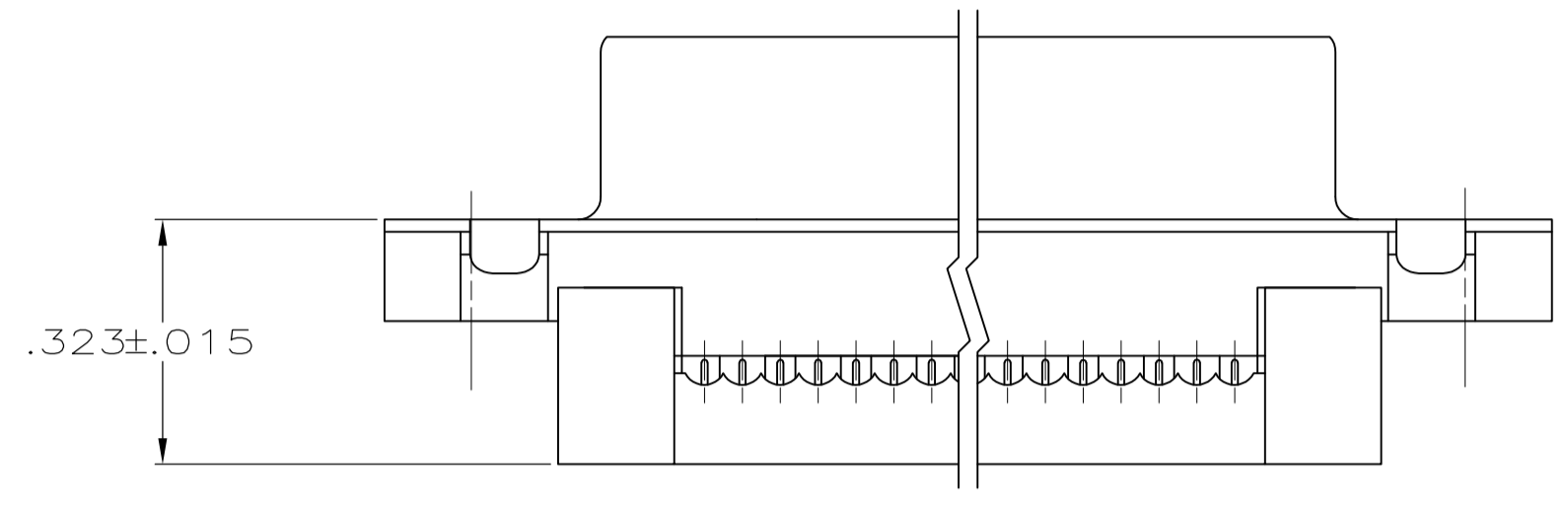

TERMINATED VIEW
W/COVER ASSEMBLED

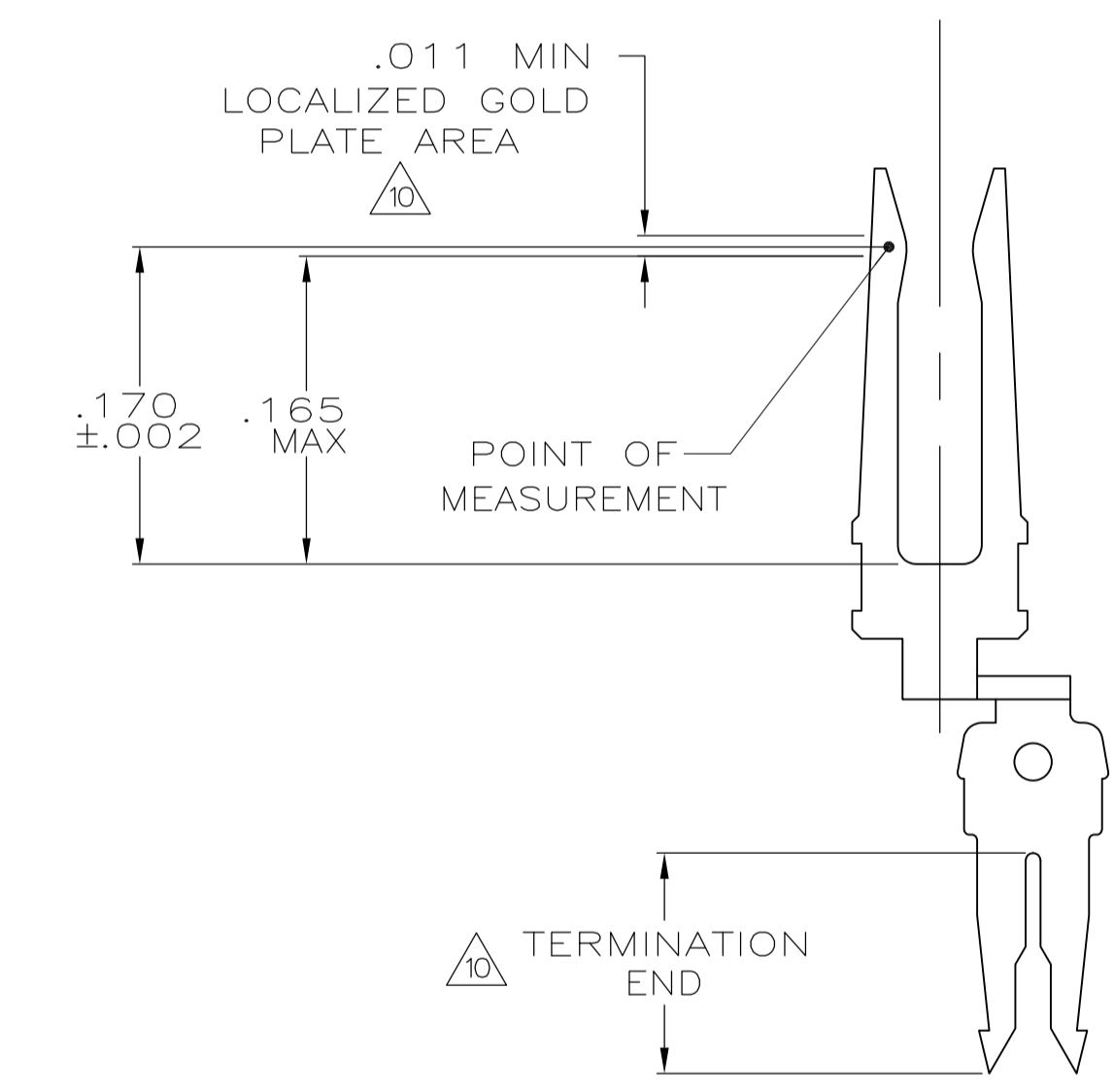
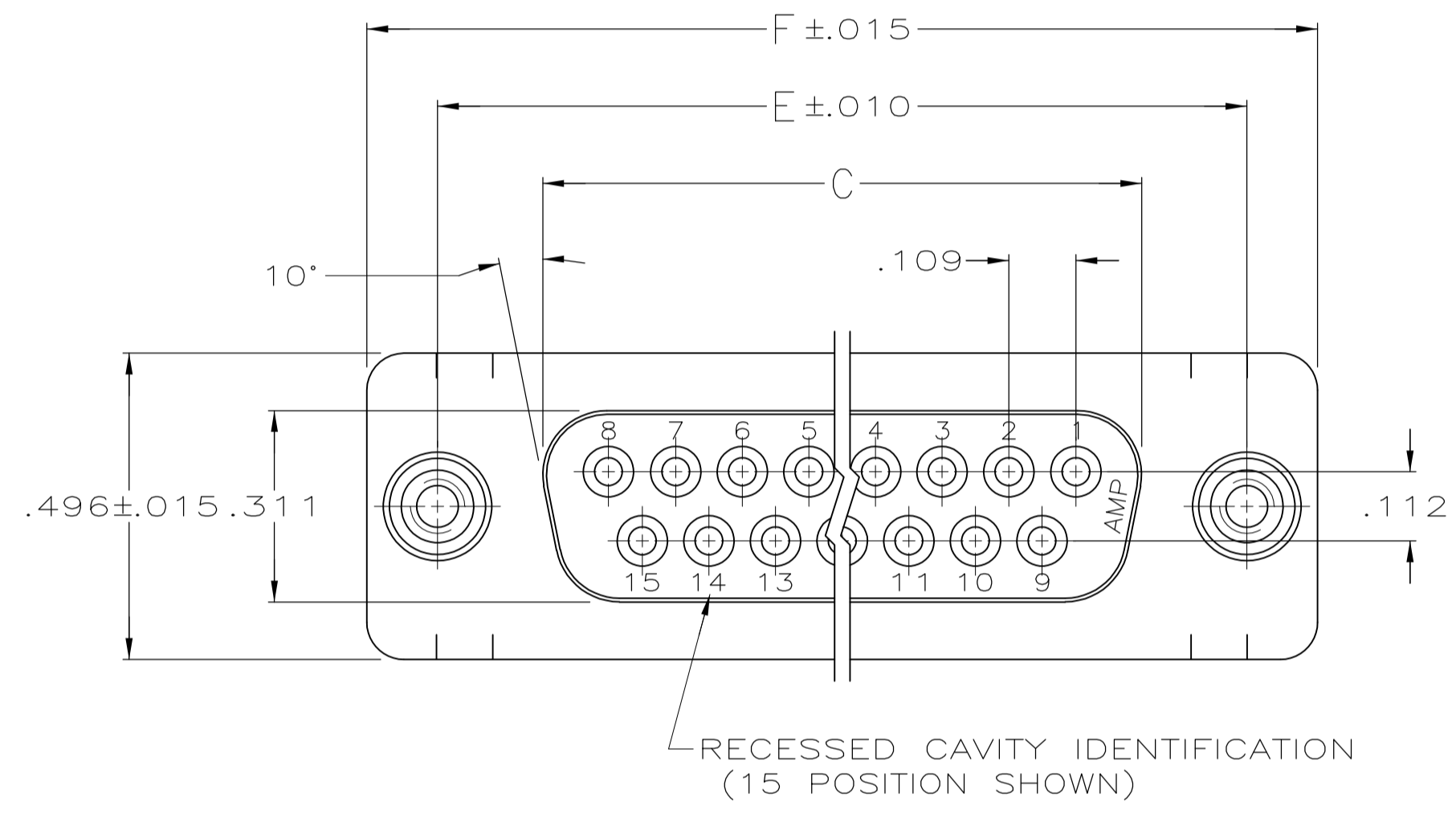

CONTACT DETAIL

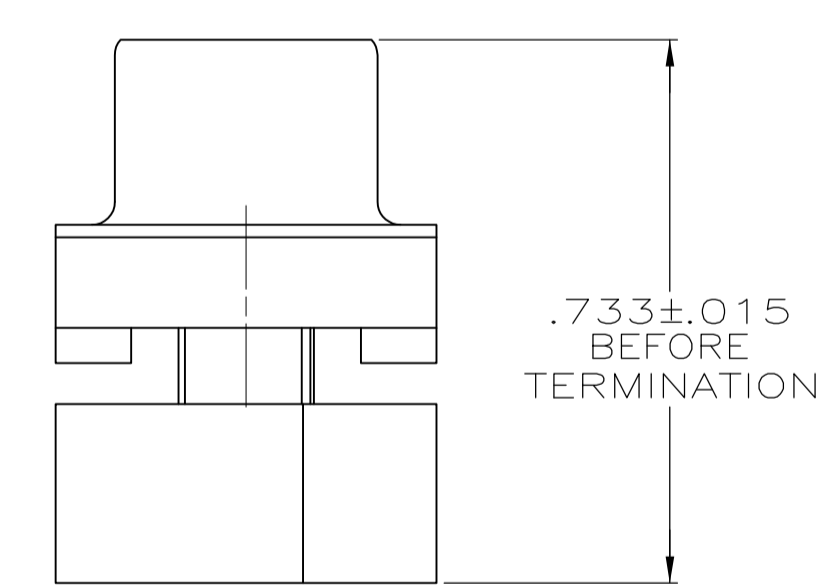
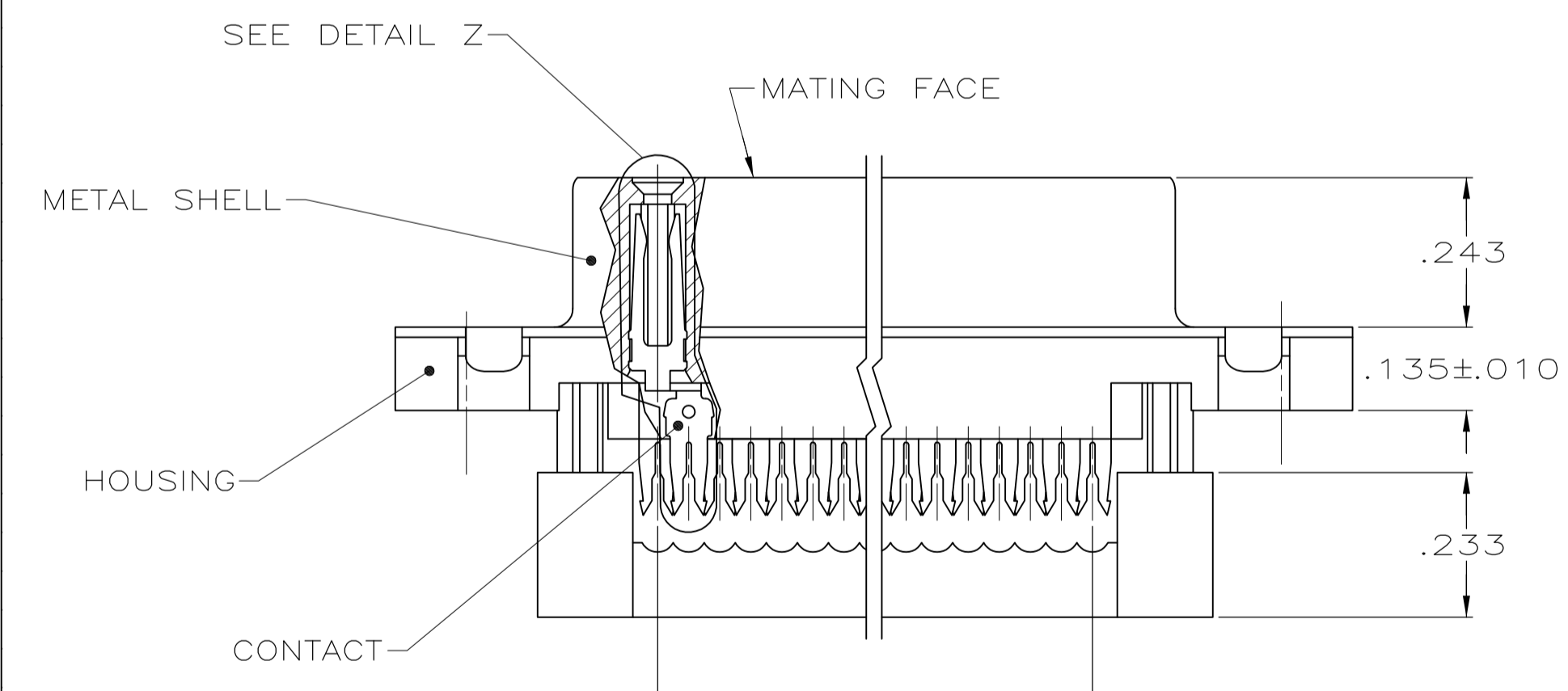

A SPACES AT .050 STAGGERED SPACING = B REF

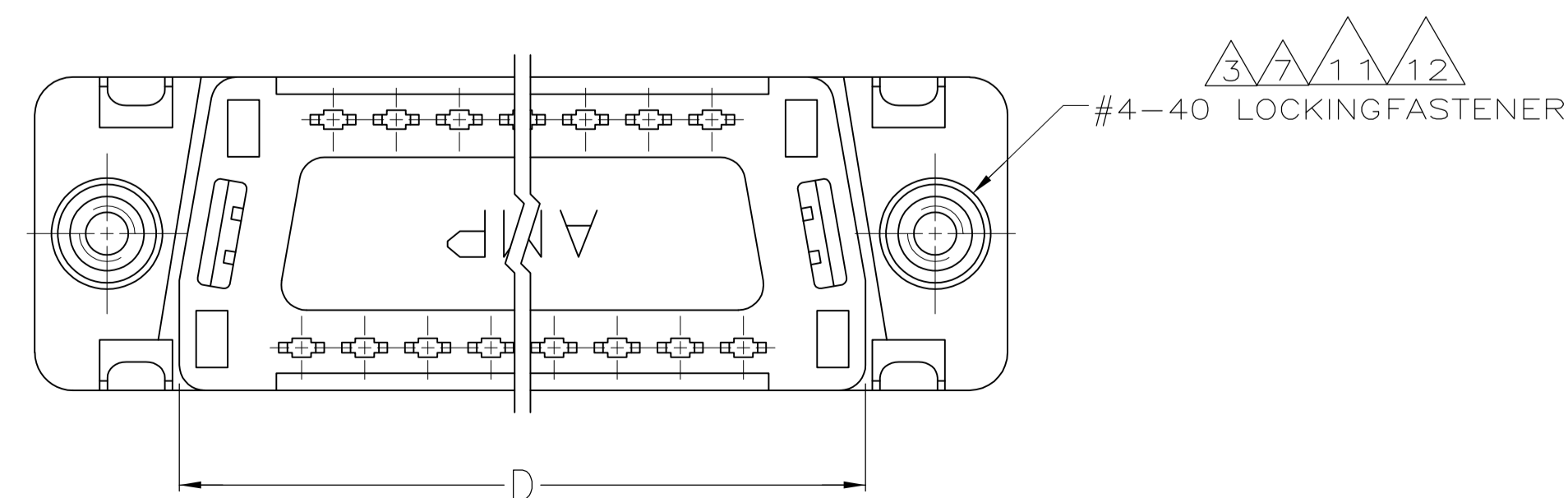

OBsolete	F	E	D	C	B	A	NO OF POS	PART NUMBER
	1.216	.984	.759	.643	.400	8	9	5746861-4
	1.541	1.312	1.087	.971	.700	14	15	5746861-3
	2.090	1.852	1.623	1.511	1.200	24	25	5746861-2

THIS DRAWING IS A CONTROLLED DOCUMENT.		DIN B MCMASITER 31MAR04	TE Connectivity
DIMENSIONS: INCHES		CIK C ROHDE 31MAR04	
TOLERANCES UNLESS OTHERWISE SPECIFIED:		APVD M WALMSLEY 31MAR04	NAME
0 PLC ± -			RECEPTACLE ASSY, LOW PROFILE HDF, FRONT METAL SHELL, W/PREASSEMBLED COVER & LOCKING FASTENERS
1 PLC ± -			PRODUCT SPEC
2 PLC ± -			APPLICATION SPEC
3 PLC ± .005			SIZE
4 PLC ± - # 2			WEIGHT
ANGLES ± - # 2			SCALE
MATERIAL	FINISH	WEIGHT	RESTRICTED TO
4 5 6 7 8 9 10 11		A1 00779 C=5746861	1 OF 1 REV C2