

Figure 1

1. INTRODUCTION

Housing Removal Tool 1338744-1 shown in Figure 1 is designed to remove the receptacle housing from a 6- or 10-row Z-PACK* HM or HS3 backplane receptacle connector on a printed circuit (pc) board.

The removal tool is designed for use in Pistol Grip Manual Handle Assembly 58074-1. For set up and operation of the manual hand assembly, refer to instruction sheet 408-6790.

NOTE *Dimensions on this instruction sheet are in metric [with U.S. customary units in brackets]. Figures are not drawn to scale.*

Reasons for reissue of this instruction sheet are provided in Section 7, REVISION SUMMARY.

2. DESCRIPTION

When properly inserted into the manual handle assembly, the removal tool will clamp the receptacle housing while removing it from the remaining part of the connector. Features of the removal tool and their functions are as follows:

Upper and Lower Clamps — used to clamp the housing into the removal tool.

Screw Clamp — used to adjust the clamps for the different housing sizes.

Insertion Adjuster Rod — used to mount into the manual handle assembly and to adjust stroke length.

Side Push Bars — used to push on the pc board.

3. ADJUSTMENT

If the removal tool requires more travel to remove the receptacle housing, remove the removal tool from the manual handle assembly and turn the insertion adjuster rod *counterclockwise* to increase the travel.

NOTE *This setting is normally pre-set and will not need adjustment.*

4. HOUSING REMOVAL PROCEDURE

1. Select the connector that requires housing removal.
2. Position the removal tool over the connector as shown in Figure 2.
3. Using the screw clamp, close the upper clamp onto the housing until the latches on the clamps lock behind the front edge of the housing and the connector is held firmly with the tool. See Figure 2.
4. Activate the manual handle assembly. This will remove the housing from the remaining part of the connector.
5. Loosen the screw clamp, and remove the connector from removal tool.

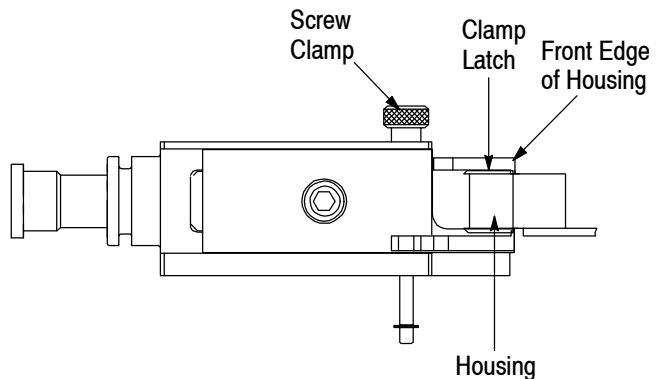

Figure 2

5. MAINTENANCE AND INSPECTION

5.1. Daily Maintenance

It is recommended that each operator of the removal tool be made aware of, and responsible for, the following steps of daily maintenance:

1. Remove dust, moisture, and other contaminants with a clean brush or a soft, lint-free cloth.
2. Make sure all components are in place and properly secured.
3. Actuate the removal tool to ensure all mechanisms of the tool move smoothly.

5.2. Periodic Inspection

Regular inspections should be performed by quality control personnel. A record of scheduled inspections should remain with the removal tool or be supplied to personnel responsible for the removal tool. Though recommendations call for at least one inspection a month, the inspection frequency should be based on the amount of use, ambient working conditions, operator training and skill, and established company standards. These inspections should include a visual inspection and should be performed in the sequence listed:

1. Remove any accumulated dirt and debris that could affect the operation of the removal tool.
2. Make sure all components are in place and are properly secured.
3. Check for chipped, cracked, worn, or broken areas. If damage is evident, repair is necessary. See Section 6, REPLACEMENT AND REPAIR.

6. REPLACEMENT AND REPAIR

Replacement parts are listed in Figure 3. Parts other than those listed in Figure 3 should be replaced by Tyco Electronics to ensure quality and reliability of the removal tool. Order replacement parts through your representative, or call 1-800-526-5142, or send a facsimile of your purchase order to 1-717-986-7605, or write to:

CUSTOMER SERVICE (38-35)
 TYCO ELECTRONICS CORPORATION
 PO BOX 3608
 HARRISBURG PA 17105-3608

For customer repair service, call 1-800-526-5136.

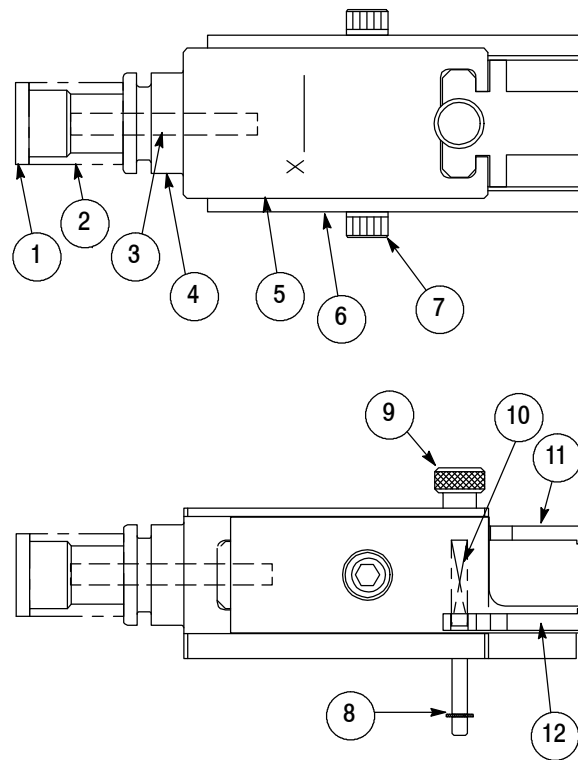

REPLACEMENT PARTS			
ITEM	PART NUMBER	DESCRIPTION	QTY PER TOOL
1	312149-1	ROD, Insertion Adjuster	1
2	22488-5	SPRING, Compression	1
3	1-21007-2	SCREW, Set	1
4	1320254-1	HEAD, Machined	1
5	1338748-1	BAR, Drive	1
6	1338749-1	BAR, Side Push	2
7	21000-7	SCREW, Socket Head Cap	2
8	21986-4	RING, Retaining	2
9	1320261-1	SCREW, Clamp	1
10	2-22278-1	SPRING, Compression	2
11	1338753-1	CLAMP, Upper	1
12	1338754-1	CLAMP, Lower	1

Figure 3

7. REVISION SUMMARY

Revisions to this instruction sheet include:

- Updated instruction sheet to corporate requirements