

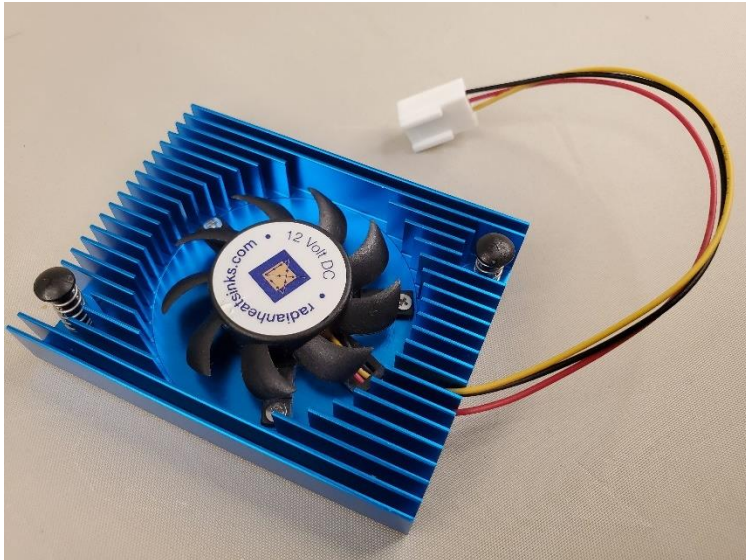

# radian

## Sub-Zero PCIe Fansink – SZ12L

Radian Thermal Products has been committed to helping our customers with full-service mechanical and thermal solutions since 1974. Radian offers a range of standard PCIe active and passive cooling solutions as well as custom designs to meet customer requirements.



### Description:

- Sub-Zero PCIe Fansink, 50 x 63.4 x 10.5mm, 12V

Buy Online at:

[Radianheatsinks.com](http://Radianheatsinks.com)

<b>PART</b>	SZ12L
<b>MOUNTING</b>	Push Pin
<b>MATERIAL</b>	Aluminum
<b>LENGTH (mm)</b>	63.4
<b>WIDTH (mm)</b>	50.0
<b>HEIGHT (mm)</b>	10.5
<b>VOLTAGE (V DC)</b>	12.0

### Model Numbering System

Part numbers can be customized as follows:

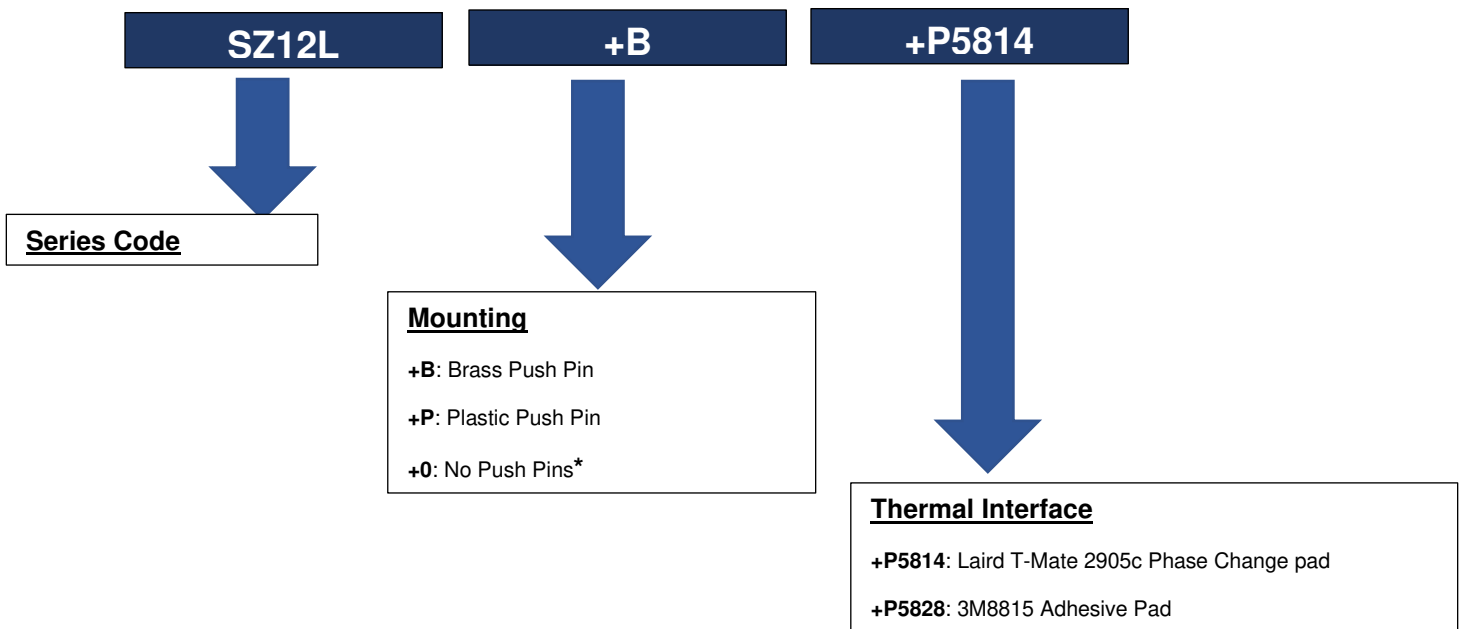

**\*Must be combined with 3M8815 Adhesive Pad.**

## Fansink Specifications

### Thermal Data

$\Theta_{SA}^1$ (°C/W)	1.85
TIM Options	3M 8815 Adhesive Pad
	LAIRD T-MATE 2905c
	Contact Radian for other options

### Mechanical Data

Assembly Dimensions	See Figure 1
Heatsink Material	Aluminum
Surface Finish	Radian Blue Anodized
Force per Push Pin (lb <sub>r</sub> )	Brass: 1.6 ±15% Maximum
	Plastic: 1.6 ±15% Maximum
Push Pin Effective Length (mm) (See Figure 2)	Brass: 13.72 ±0.127
	Plastic: 12.29 ±0.127
Maximum Combined Thickness (mm) <sup>2</sup>	Brass: 11
	Plastic: 9.5
Push Pin Extension Length under PCB (mm) (See Figure 2)	Brass: 2.16 ±0.127
	Plastic: 3.2 ±0.127
Recommended PCB Hole Diameter for Push Pin (mm)	Brass: 3.0
	Plastic: 3.2
Connector	Molex 22-01-3037
Connector Receptacle	Mates KK 254 PCB Headers
Mass (g)	30
Noise (dB)	33.85

### Electrical Data

Operating Voltage (V <sub>DC</sub> )	12
	13.8 Max
Connector Pins	08-50-0114 OR EQUIVALENT
Starting Voltage (VDC)	9 (ON/OFF)
Input Current (A)	0.1 (Max. 0.12)
Wire Description	See Figure 1
Signal Circuit	See Figure 3
Fan Speed (RPM)	7,500 ±15%

### Environmental Data

Operating Temperature (°C)	-10 to +70
Storage Temperature (°C)	-40 to +75
Operating Humidity (%RH)	35 to 85
Storage Humidity (%RH)	35 to 85
Average Life Expectancy	70,000 hours operation at rated voltage in 40°C with 15~65%RH

<sup>1</sup> Typical value, actual performance may vary depending on application environment.

<sup>2</sup> Combined thickness is the sum of the PCB, chip, thermal pad and heatsink base thicknesses.

## Fansink Assembly Drawings

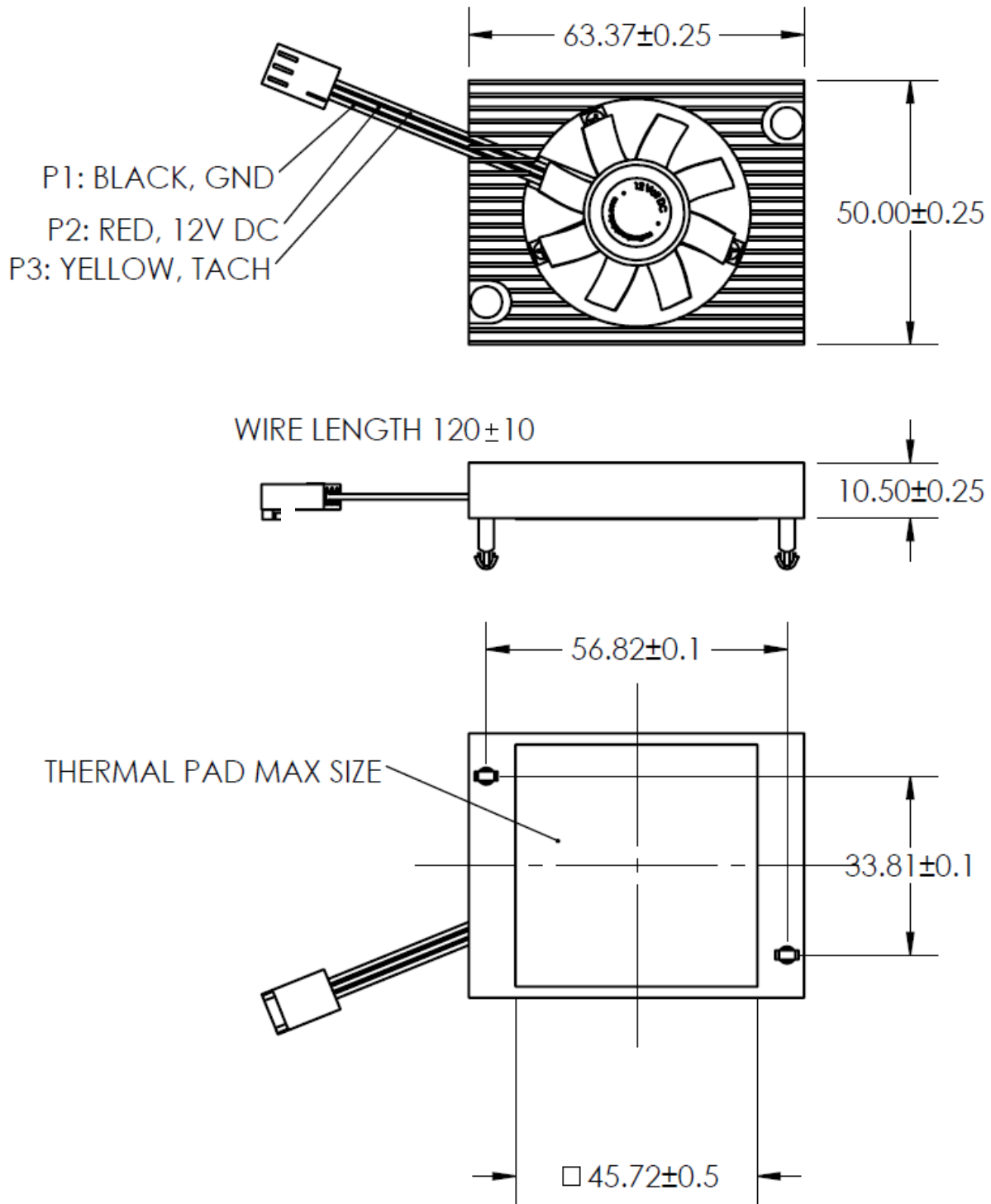

Figure 1: SZ12L Mechanical Drawings

## Push Pin Illustration

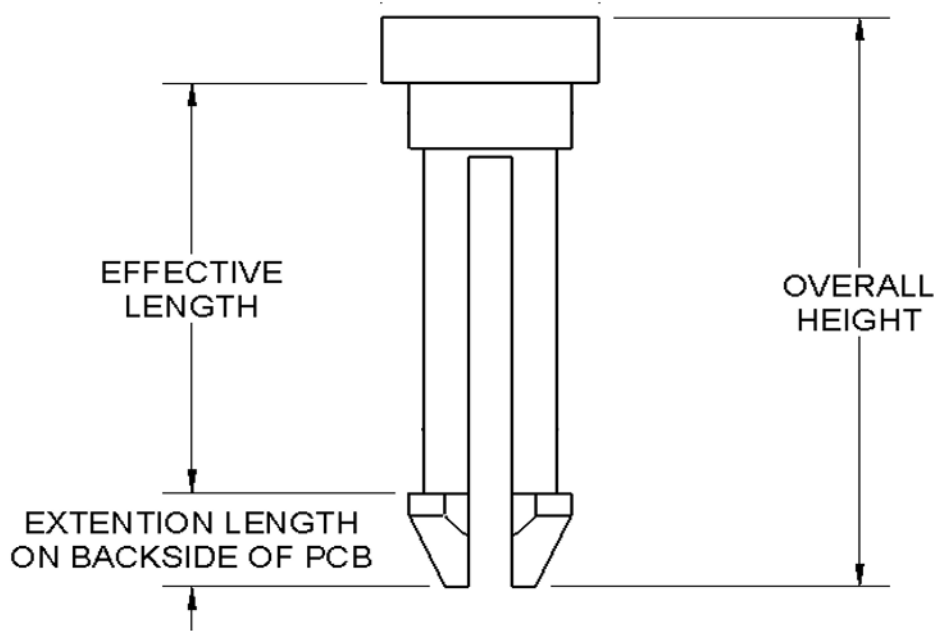
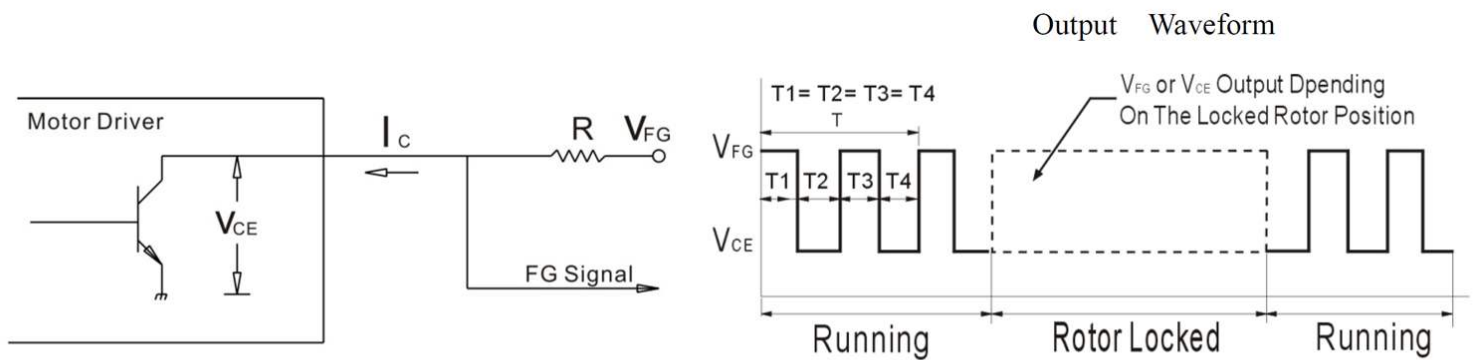

Figure 2: Push Pin Illustration

## Fan Circuit Schematic



Output Type : Open Collect

$V_{CE(sat)} = 0.5V(\text{Max.})$

$I_C = 5mA(\text{Max.})$

$V_{FG} = \text{Maximum operation voltage}$

$R \geq V_{FG} / I_C$

$N = \text{R.P.M}$  ;  $T = 60/N(\text{Sec.})$  ;  $FG = 1/T * 2(\text{Hz})$  ;  $N = FG * 30$

Figure 3: SZ12L Signal Circuit Schematic