

FMS6146

Low-Cost Six-Channel 4th-Order Standard Definition Video Filter Driver

Features

- Six 4th-Order 8MHz (SD) Filters
- Drives Single, AC- or DC-Coupled, Video Loads ($2V_{pp}$, 150Ω)
- Drives Dual, AC- or DC-Coupled, Video Loads ($2V_{pp}$, 75Ω)
- Transparent Input Clamping
- AC- or DC-Coupled Inputs
- AC- or DC-Coupled Outputs
- DC-Coupled Outputs Eliminate AC-Coupling Capacitors
- 5V Only
- Robust 8kV ESD Protection
- Lead-free TSSOP-14 Package

Applications

- Cable Set-Top Boxes
- Satellite Set-Top Boxes
- DVD Players
- HDTV
- Personal Video Recorders (PVR)
- Video On Demand (VOD)

Description

The FMS6146 Low-Cost Video Filter (LCVF) is intended to replace passive LC filters and drivers with a low-cost integrated device. Six 4th-order filters provide improved image quality compared to typical 2nd or 3rd-order passive solutions.

The FMS6146 may be directly driven by a DC-coupled DAC output or an AC-coupled signal. Internal diode clamps and bias circuitry may be used if AC-coupled inputs are required (*see the Applications section for details*).

The outputs can drive AC- or DC-coupled single (150Ω) or dual (75Ω) loads. DC coupling the outputs removes the need for output coupling capacitors. The input DC levels are offset approximately $+280\text{mV}$ at the output (*see the Applications section for details*).

Functional Block Diagram

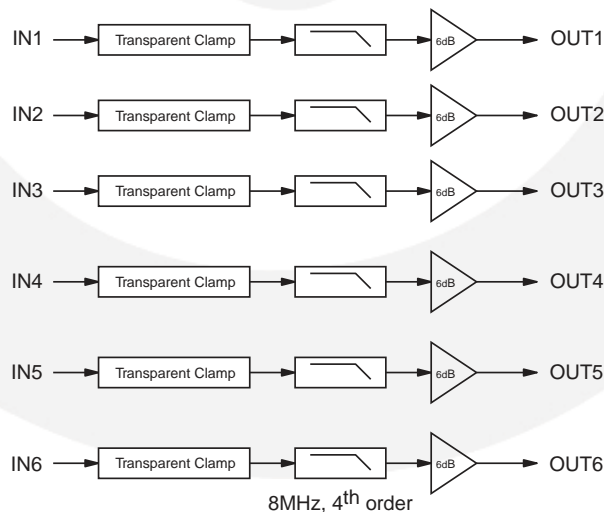

Ordering Information

Part Number	Operating Temperature Range	Eco Status	Package	Packaging Method
FMS6146MTC14X	-40°C to +85°C	RoHS	TSSOP-14	Tape and Reel

 For Fairchild's definition of Eco Status, please visit: http://www.fairchildsemi.com/company/green/rohs_green.html.

Pin Configuration

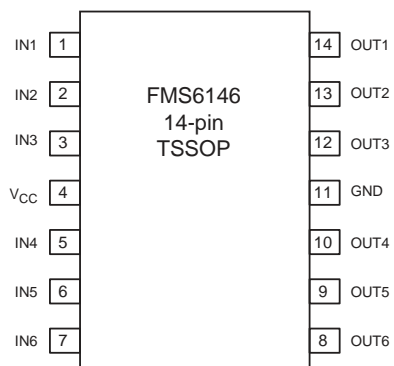

Pin Assignments

Pin#	Pin Name	Type	Description
1	IN1	Input	Video input, Channel 1
2	IN2	Input	Video input, Channel 2
3	IN3	Input	Video input, Channel 3
4	V _{CC}	Input	+5V supply, do not float
5	IN4	Input	Video input, Channel 4
6	IN5	Input	Video input, Channel 5
7	IN6	Input	Video input, Channel 6
8	OUT6	Output	Filtered video output, Channel 6
9	OUT5	Output	Filtered video output, Channel 5
10	OUT4	Output	Filtered video output, Channel 4
11	GND	Output	Must be tied to ground, do not float
12	OUT3	Output	Filtered video output, Channel 3
13	OUT2	Output	Filtered video output, Channel 2
14	OUT1	Output	Filtered video output, Channel 1

Absolute Maximum Ratings

Stresses exceeding the absolute maximum ratings may damage the device. The device may not function or be operable above the recommended operating conditions and stressing the parts to these levels is not recommended. In addition, extended exposure to stresses above the recommended operating conditions may affect device reliability. The absolute maximum ratings are stress ratings only.

Parameter	Min.	Max.	Unit
DC Supply Voltage	-0.3	6	V
Analog and Digital I/O	-0.3	$V_{CC} + 0.3$	V
Output Channel - Any One Channel (Do Not Exceed)		50	mA

Reliability Information

Symbol	Parameter	Min.	Typ.	Max.	Unit
T_J	Junction Temperature			+150	°C
T_{STG}	Storage Temperature Range	-65		+150	°C
T_L	Lead Temperature (Soldering, 10 seconds)			+300	°C
Θ_{JA}	Thermal Resistance, JEDEC Standard Multi-layer Test Boards, Still Air		90		°C/W

Electrostatic Discharge Information

Symbols	Parameter	Max.	Unit
ESD	Human Body Model, JESD22-A114	4	kV
	Charged Device Model, JESD22-C101	2	

Recommended Operating Conditions

The Recommended Operating Conditions table defines the conditions for actual device operation. Recommended operating conditions are specified to ensure optimal performance to the datasheet specifications. Fairchild does not recommend exceeding them or designing to absolute maximum ratings.

Parameter	Min.	Typ.	Max.	Unit
Operating Temperature Range	-40		+85	°C
V_{CC} Range	+4.75	+5.0	+5.25	V

DC Electrical Characteristics

$T_A = 25^\circ\text{C}$, $V_{CC} = 5\text{V}$, $R_{SOURCE} = 37.5\Omega$; all inputs are AC coupled with $0.1\mu\text{F}$; all outputs are AC coupled with $220\mu\text{F}$ into 150Ω loads; unless otherwise noted.

Symbol	Parameter	Conditions	Min.	Typ.	Max.	Units
I_{CC}	Supply Current ⁽¹⁾	FMS6146 (No Load)		35	55	mA
V_{IN}	Video Input Voltage Range	Referenced to GND if DC coupled		1.4		V_{pp}
PSRR	Power Supply Rejection	DC (All Channels)		-50		dB

Note:

1. 100% tested at 25°C .

AC Electrical Characteristics

$T_A = 25^\circ\text{C}$, $V_{IN} = 1V_{pp}$, $V_{CC} = 5\text{V}$, $R_{SOURCE} = 37.5\Omega$; all inputs are AC coupled with $0.1\mu\text{F}$; all outputs are AC coupled with $220\mu\text{F}$ into 150Ω loads; unless otherwise noted.

Symbol	Parameter	Conditions	Min.	Typ.	Max.	Units
AV	Channel Gain ⁽¹⁾	All Channels	6.0	6.2	6.4	dB
f_{1dB}	-1dB Bandwidth ⁽¹⁾	All Channels	4.5	6.8		MHz
f_c	-3dB Bandwidth	All Channels		7.8		MHz
f_{SB}	Attenuation (Stopband Reject)	All Channels at $f = 27\text{MHz}$		48		dB
dG	Differential Gain	All Channels		0.3		%
$d\phi$	Differential Phase	All Channels		0.6		$^\circ$
THD	Output Distortion (All Channels)	$V_{OUT} = 1.8V_{pp}$, 1MHz		0.4		%
X_{TALK}	Crosstalk (Channel-to-Channel)	at 1MHz		-60		dB
SNR	Signal-to-Noise Ratio	All Channels NTC-7 Weighting: 100kHz to 4.2MHz		75		dB
t_{pd}	Propagation Delay	Delay from Input-to-Output, 4.5MHz		59		ns

Note:

1. 100% tested at 25°C .

Typical Performance Characteristics

$T_A = 25^\circ\text{C}$, $V_{CC} = 5\text{V}$, $R_{SOURCE} = 37.5\Omega$; all inputs AC coupled with $0.1\mu\text{F}$; all outputs are AC coupled with $220\mu\text{F}$ into 150Ω loads; unless otherwise noted.

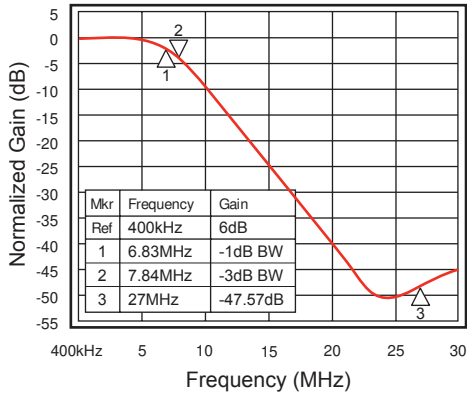

Figure 1. Frequency Response

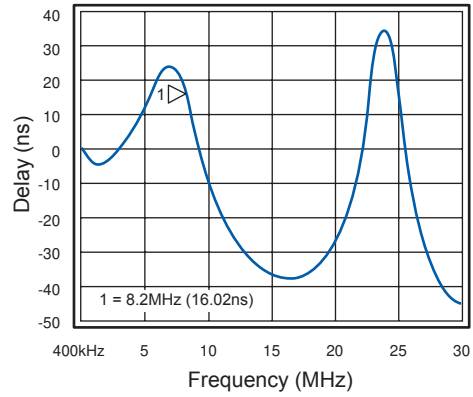

Figure 2. Group Delay vs. Frequency

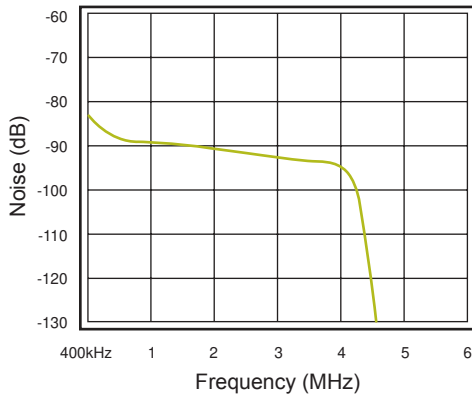

Figure 3. Noise vs. Frequency

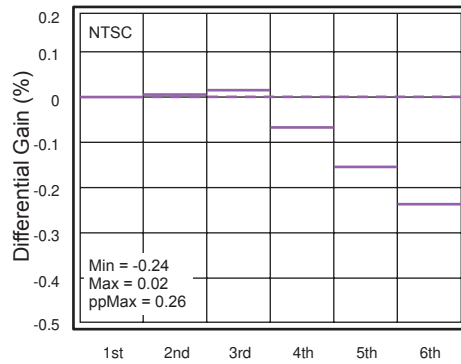

Figure 4. Differential Gain

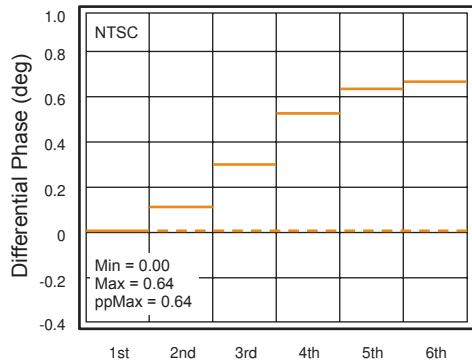

Figure 5. Differential Phase

Typical Application Diagrams

The following circuit may be used for direct DC-coupled drive by DACs with an output voltage range of 0V to 1.4V. AC-coupled or DC-coupled outputs may be used with AC-coupled outputs, offering slightly lower power dissipation.

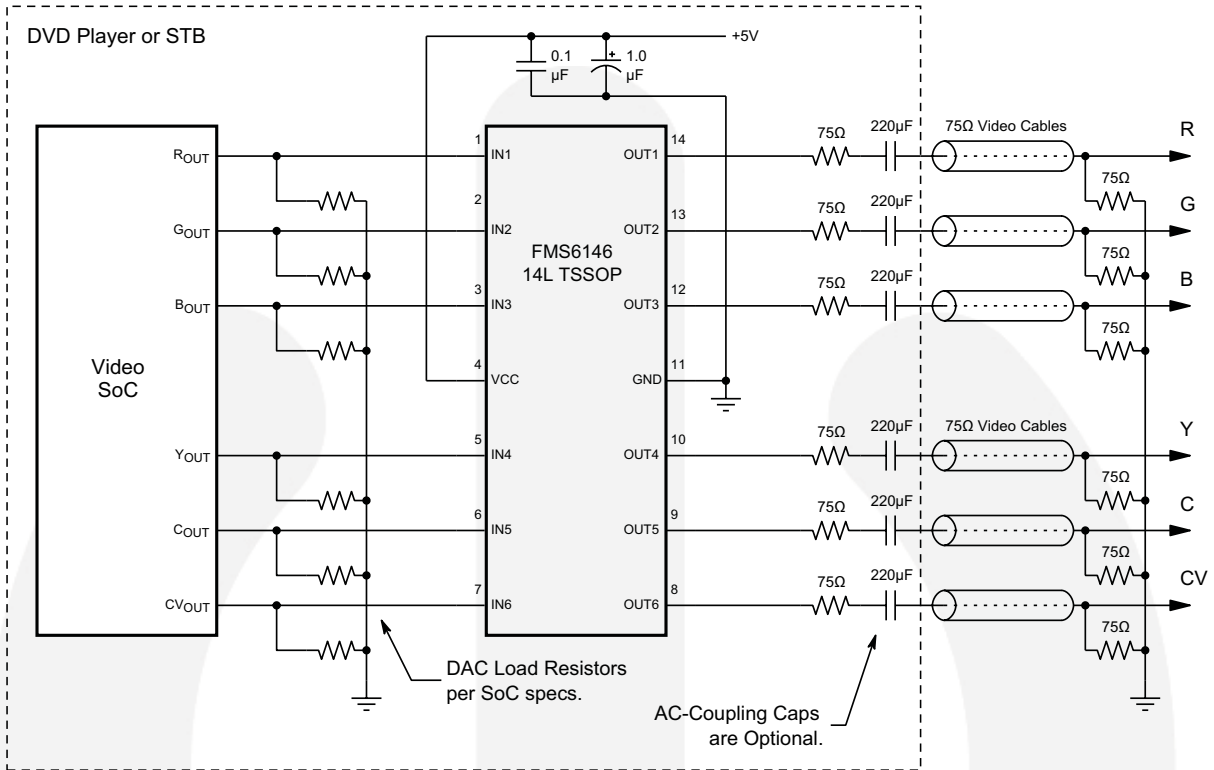
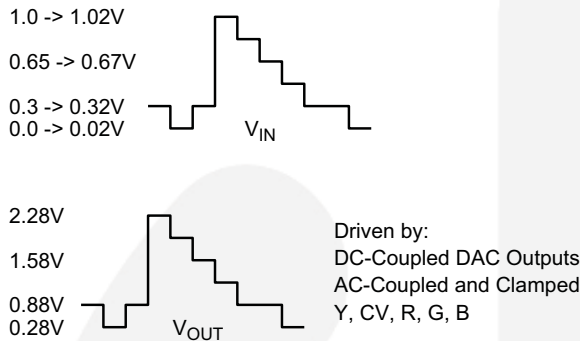

Figure 6. Typical Application Diagram

Application Information

Application Circuits

The FMS6146 Low Cost Video Filter (LCVF) provides 6dB gain from input to output. In addition, the input is slightly offset to optimize the output driver performance. The offset is held to the minimum required value to decrease the standing DC current into the load. Typical voltage levels are shown in the diagram below:



There is a 280mV offset from the DC input level to the DC output level. $V_{OUT} = 2 * V_{IN} + 280mV$.

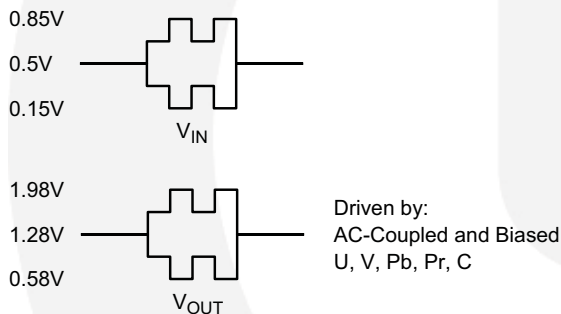

Figure 7. Typical Voltage Levels

The FMS6146 provides an internal diode clamp to support AC-coupled input signals. If the input signal does not go below ground, the input clamp does not operate. This allows DAC outputs to directly drive the FMS6146 without an AC coupling capacitor. When the input is AC coupled, the diode clamp sets the sync tip (or lowest voltage) just below ground. The worst-case sync tip compression due to the clamp cannot exceed 7mV. The input level set by the clamp, combined with the internal DC offset, keeps the output within its acceptable range.

For symmetric signals like Chroma, U, V, Pb, and Pr, the average DC bias is fairly constant and the inputs can be AC coupled with the addition of a pull-up resistor to set the DC input voltage. DAC outputs can also drive these same signals without the AC coupling capacitor. A conceptual illustration of the input clamp circuit is shown in Figure 8.

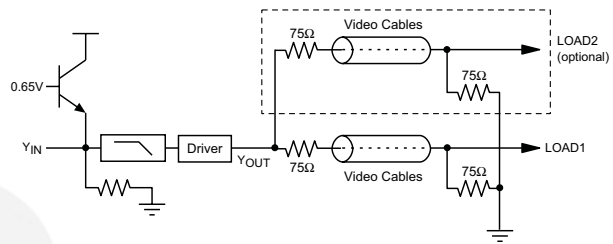

Figure 8. Input Clamp Circuit

I/O Configurations

For a DC-coupled DAC drive with DC-coupled outputs, use the configuration shown in Figure 9.

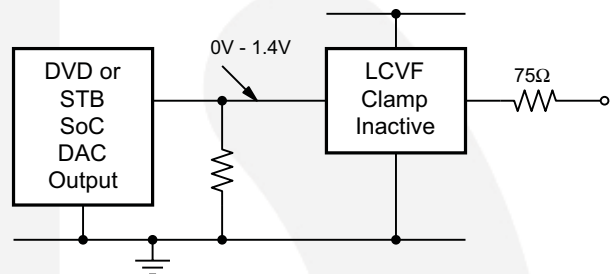

Figure 9. DC-Coupled Inputs and Outputs

Alternatively, if the DAC's average DC output level causes the signal to exceed the range of 0V to 1.4V, it can be AC coupled as shown in Figure 10.

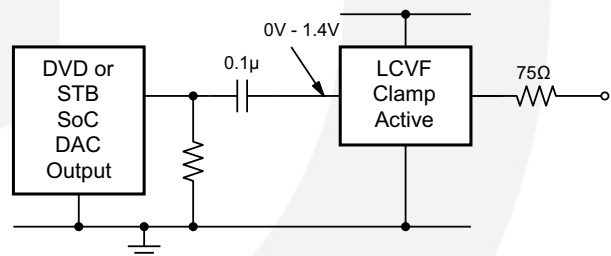

Figure 10. AC-Coupled Inputs, DC-Coupled Outputs

When the FMS6146 is driven by an unknown external source or a SCART switch with its own clamping circuitry, the inputs should be AC coupled as shown in Figure 11.

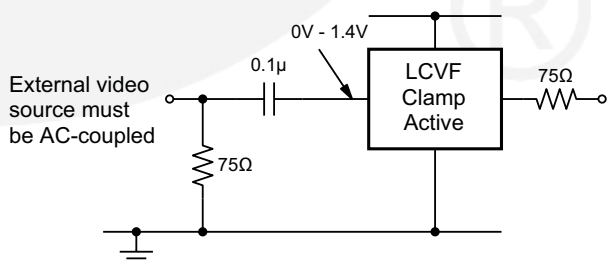

Figure 11. SCART with DC-Coupled Outputs

The same method can be used for biased signals, with the addition of a pull-up resistor to make sure the clamp never operates. The internal pull-down resistance is $800k\Omega \pm 20\%$, so the external resistance should be $7.5M\Omega$ to set the DC level to $500mV$ as shown in Figure 12.

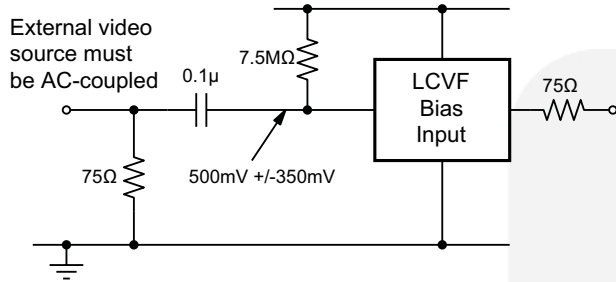

Figure 12. Biased SCART with DC-Coupled Outputs

The same circuits can be used with AC-coupled outputs if desired.

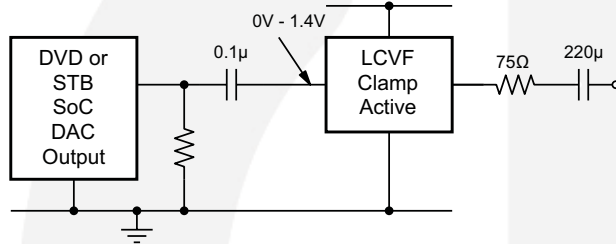

Figure 13. DC-Coupled Inputs, AC-Coupled Outputs

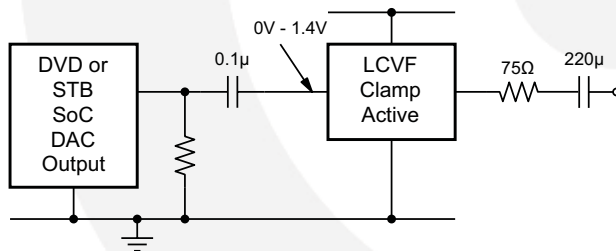

Figure 14. AC-Coupled Inputs and Outputs

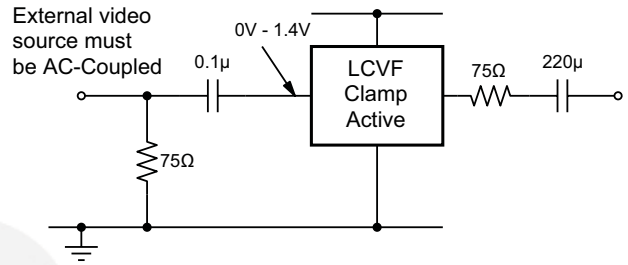

Figure 15. Biased SCART with AC-Coupled Outputs

NOTE: The video tilt or line time distortion is dominated by the AC-coupling capacitor. The value may need to be increased beyond $220\mu F$ to obtain satisfactory operation in some applications.

Power Dissipation

The FMS6146 output drive configuration must be considered when calculating overall power dissipation. Care must be taken not to exceed the maximum die junction temperature. The following example can be used to calculate the FMS6146's power dissipation and internal temperature rise.

$$T_j = T_A + P_d \cdot \theta_{JA} \quad \text{EQ. 1}$$

$$\text{where: } P_d = P_{CH1} + P_{CH2} + P_{CH3} \quad \text{and} \quad \text{EQ. 2}$$

$$P_{CHx} = V_{CC} \cdot I_{CH} - (V_O^2/R_L) \quad \text{EQ. 3}$$

$$\text{where: } V_O = 2V_{IN} + 0.280V \quad \text{EQ. 4}$$

$$I_{CH} = (I_{CC}/3) + (V_O/R_L) \quad \text{EQ. 5}$$

V_{IN} = RMS value of input signal

I_{CC} = 35mA

V_{CC} = 5V

R_L = channel load resistance

Board layout can also affect thermal characteristics. Refer to *Layout Considerations* for more information.

The FMS6146 is specified to operate with output currents typically less than 50mA, more than sufficient for a dual (75Ω) video load. Internal amplifiers are current limited to a maximum of 100mA and should withstand brief-duration short-circuit conditions; this capability is not guaranteed.

Layout Considerations

General layout and supply bypassing play major roles in high-frequency performance and thermal characteristics. Fairchild offers a demonstration board, FMS6146DEMO, to guide layout and aid device testing and characterization. The FMS6146DEMO is a four-layer board with full power and ground planes. Following this layout configuration provides the optimum performance and thermal characteristics. For optimum results, follow the guidelines below as a basis for high-frequency layout:

- Include 1 μ F and 0.1 μ F ceramic bypass capacitors.
- Place the 1 μ F capacitor within 0.75 inches of the power pin.
- Place the 0.1 μ F capacitor within 0.1 inches of the power pin.
- For multi-layer boards, use a large ground plane to help dissipate heat.
- For two-layer boards, use a ground plane that extends beyond the device by at least 0.5 inches.
- Minimize all trace lengths to reduce series inductances.

Output Considerations

The FMS6146 outputs are DC offset from the input by 150mV. Therefore, $V_{OUT} = 2 \cdot V_{IN} DC + 150mV$. This offset is required to obtain optimal performance from the output driver and is held at the minimum value to decrease the standing DC current into the load. Since the FMS6146 has a 2x (6dB) gain, the output is typically connected via a 75 Ω -series back-matching resistor, followed by the 75 Ω video cable. Due to the inherent divide by two of this configuration, the blanking level at the load of the video signal is always less than 1V. When AC-coupling the output, ensure that the coupling capacitor of choice passes the lowest frequency content in the video signal and that line time distortion (video tilt) is kept as low as possible.

The selection of the coupling capacitor is a function of the subsequent circuit input impedance and the leakage current of the input being driven. To obtain the highest quality output video signal, the series termination resistor must be placed as close to the output pin as possible. This reduces the parasitic capacitance and inductance effect on the output driver. The distance from the device pin to the series termination resistor should be no greater than 0.1 inches.

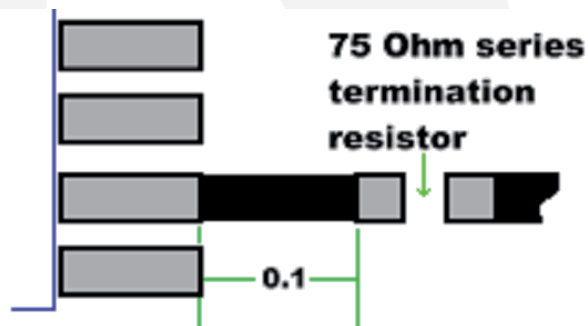
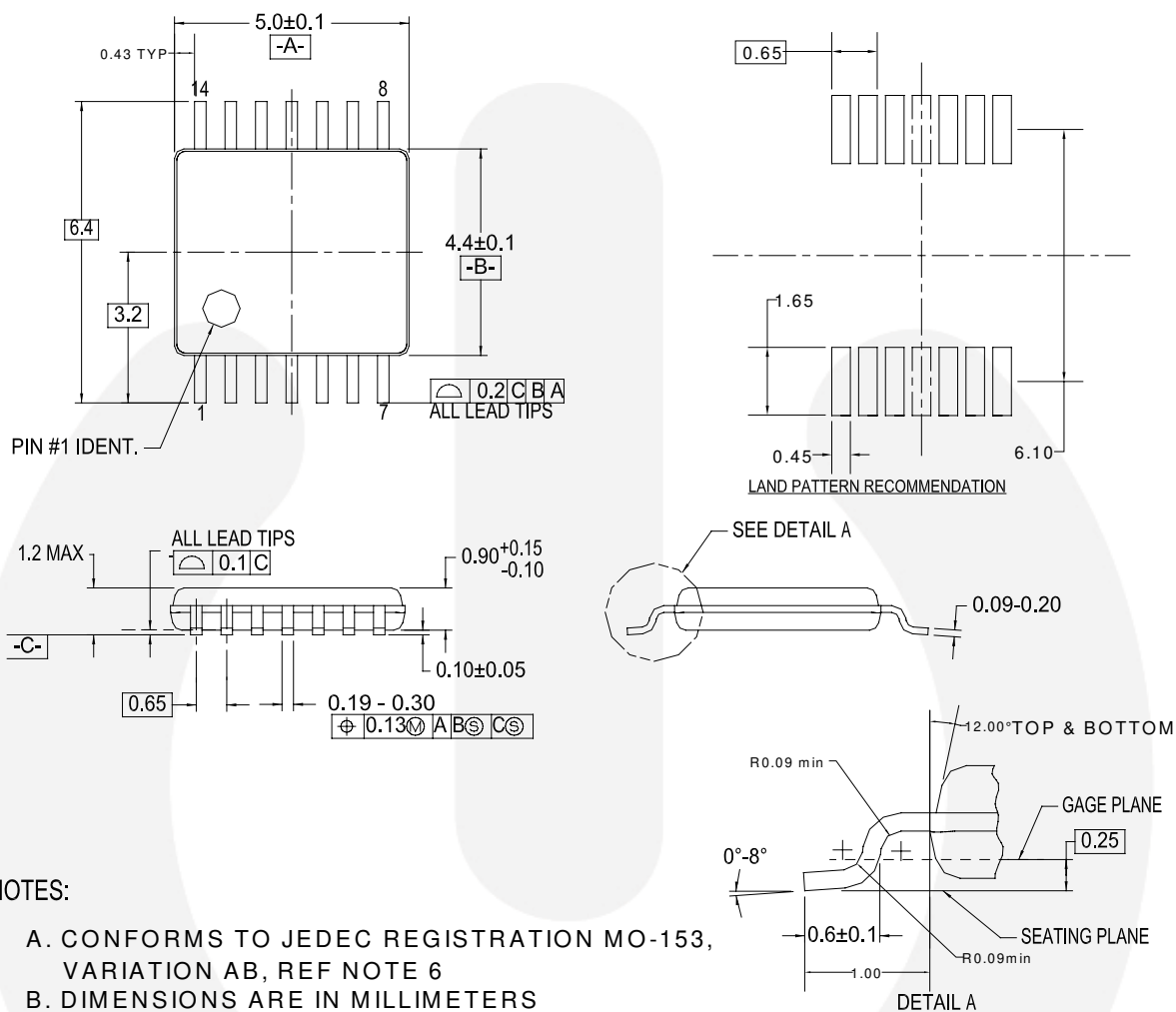

Figure 16. Distance from Device Pin to Series Termination Resistor

Physical Dimensions



NOTES:

- A. CONFORMS TO JEDEC REGISTRATION MO-153, VARIATION AB, REF NOTE 6
- B. DIMENSIONS ARE IN MILLIMETERS
- C. DIMENSIONS ARE EXCLUSIVE OF BURRS, MOLD FLASH, AND TIE BAR EXTRUSIONS
- D. DIMENSIONING AND TOLERANCES PER ANSI Y14.5M, 1982
- E. LANDPATTERN STANDARD: SOP65P640X110-14M
- F. DRAWING FILE NAME: MTC14REV6

Figure 17. TSSOP-14 Package

Package drawings are provided as a service to customers considering Fairchild components. Drawings may change in any manner without notice. Please note the revision and/or date on the drawing and contact a Fairchild Semiconductor representative to verify or obtain the most recent revision. Package specifications do not expand the terms of Fairchild's worldwide terms and conditions, specifically the warranty therein, which covers Fairchild products.

Always visit Fairchild Semiconductor's online packaging area for the most recent package drawings:

<http://www.fairchildsemi.com/packaging/>.



TRADEMARKS

The following includes registered and unregistered trademarks and service marks, owned by Fairchild Semiconductor and/or its global subsidiaries, and is not intended to be an exhaustive list of all such trademarks.

AccuPower™	FlashWriter®*	Power-SPM™	<p>SYSTEM GENERAL The Power Franchise® the power franchise TinyBoost™ TinyBuck™ TinyCalc™ TinyLogic® TINYOPTO™ TinyPower™ TinyPWM™ TinyWire™ TriFault Detect™ TRUECURRENT™* µSerDes™ SerDes UHC® Ultra FRFET™ UniFET™ VCX™ VisualMax™ XS™</p>
Auto-SPM™	FPS™	PowerTrench®	
Build it Now™	F-PFS™	PowerXS™	
CorePLUS™	FRFET®	Programmable Active Droop™	
CorePOWER™	Global Power Resource™ SM	QFET®	
CROSSVOL7™	Green FPS™	QS™	
CTL™	Green FPS™ e-Series™	Quiet Series™	
Current Transfer Logic™	Gmax™	RapidConfigure™	
EcoSPARK®	GTO™	Saving our world, 1mW/W/KW at a time™	
EfficientMax™	IntelliMAX™	SignalWise™	
EZSWITCH™**	ISOPLANAR™	SmartMax™	
™**	MegaBuck™	SMART START™	
DEUXPEED™	MICROCOUPLER™	SPM®	
™	MicroFET™	STEALTH™	
Fairchild®	MicroPak™	SuperFET™	
Fairchild Semiconductor®	MillerDrive™	SuperSOT™-3	
FACT Quiet Series™	MotionMax™	SuperSOT™-6	
FACT®	Motion-SPM™	SuperSOT™-8	
FAST®	OPTOLOGIC®	SupreMOS™	
FastvCore™	OPTOPLANAR®	SyncFET™	
FETBench™	PDP SPM™	Sync-Lock™	

* Trademarks of System General Corporation, used under license by Fairchild Semiconductor.

DISCLAIMER

FAIRCHILD SEMICONDUCTOR RESERVES THE RIGHT TO MAKE CHANGES WITHOUT FURTHER NOTICE TO ANY PRODUCTS HEREIN TO IMPROVE RELIABILITY, FUNCTION, OR DESIGN. FAIRCHILD DOES NOT ASSUME ANY LIABILITY ARISING OUT OF THE APPLICATION OR USE OF ANY PRODUCT OR CIRCUIT DESCRIBED HEREIN. NEITHER DOES IT CONVEY ANY LICENSE UNDER ITS PATENT RIGHTS, NOR THE RIGHTS OF OTHERS. THESE SPECIFICATIONS DO NOT EXPAND THE TERMS OF FAIRCHILD'S WORLDWIDE TERMS AND CONDITIONS, SPECIFICALLY THE WARRANTY THEREIN, WHICH COVERS THESE PRODUCTS.

LIFE SUPPORT POLICY

FAIRCHILD'S PRODUCTS ARE NOT AUTHORIZED FOR USE AS CRITICAL COMPONENTS IN LIFE SUPPORT DEVICES OR SYSTEMS WITHOUT THE EXPRESS WRITTEN APPROVAL OF FAIRCHILD SEMICONDUCTOR CORPORATION.

As used herein:

1. Life support devices or systems are devices or systems which, (a) are intended for surgical implant into the body or (b) support or sustain life, and (c) whose failure to perform when properly used in accordance with instructions for use provided in the labeling, can be reasonably expected to result in a significant injury of the user.
2. A critical component in any component of a life support, device, or system whose failure to perform can be reasonably expected to cause the failure of the life support device or system, or to affect its safety or effectiveness.

ANTI-COUNTERFEITING POLICY

Fairchild Semiconductor Corporation's Anti-Counterfeiting Policy. Fairchild's Anti-Counterfeiting Policy is also stated on our external website, www.fairchildsemi.com, under Sales Support.

Counterfeiting of semiconductor parts is a growing problem in the industry. All manufacturers of semiconductor products are experiencing counterfeiting of their parts. Customers who inadvertently purchase counterfeit parts experience many problems such as loss of brand reputation, substandard performance, failed applications, and increased cost of production and manufacturing delays. Fairchild is taking strong measures to protect ourselves and our customers from the proliferation of counterfeit parts. Fairchild strongly encourages customers to purchase Fairchild parts either directly from Fairchild or from Authorized Fairchild Distributors who are listed by country on our web page cited above. Products customers buy either from Fairchild directly or from Authorized Fairchild Distributors are genuine parts, have full traceability, meet Fairchild's quality standards for handling and storage and provide access to Fairchild's full range of up-to-date technical and product information. Fairchild and our Authorized Distributors will stand behind all warranties and will appropriately address any warranty issues that may arise. Fairchild will not provide any warranty coverage or other assistance for parts bought from Unauthorized Sources. Fairchild is committed to combat this global problem and encourage our customers to do their part in stopping this practice by buying direct or from authorized distributors.

PRODUCT STATUS DEFINITIONS

Definition of Terms

Datasheet Identification	Product Status	Definition
Advance Information	Formative / In Design	Datasheet contains the design specifications for product development. Specifications may change in any manner without notice.
Preliminary	First Production	Datasheet contains preliminary data; supplementary data will be published at a later date. Fairchild Semiconductor reserves the right to make changes at any time without notice to improve design.
No Identification Needed	Full Production	Datasheet contains final specifications. Fairchild Semiconductor reserves the right to make changes at any time without notice to improve the design.
Obsolete	Not In Production	Datasheet contains specifications on a product that is discontinued by Fairchild Semiconductor. The datasheet is for reference information only.

Rev. 143