

REVISIONS					
P	LTR	DESCRIPTION	DATE	DWN	APVD
B		REVISED PER ECR-19-009721	01JUL2019	M.G	D.Z

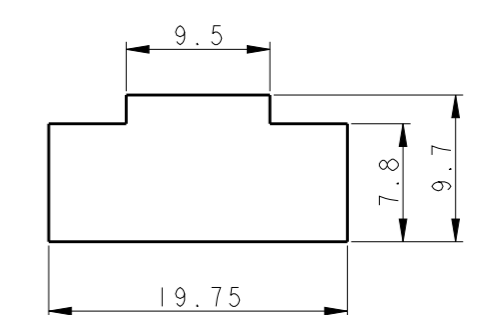
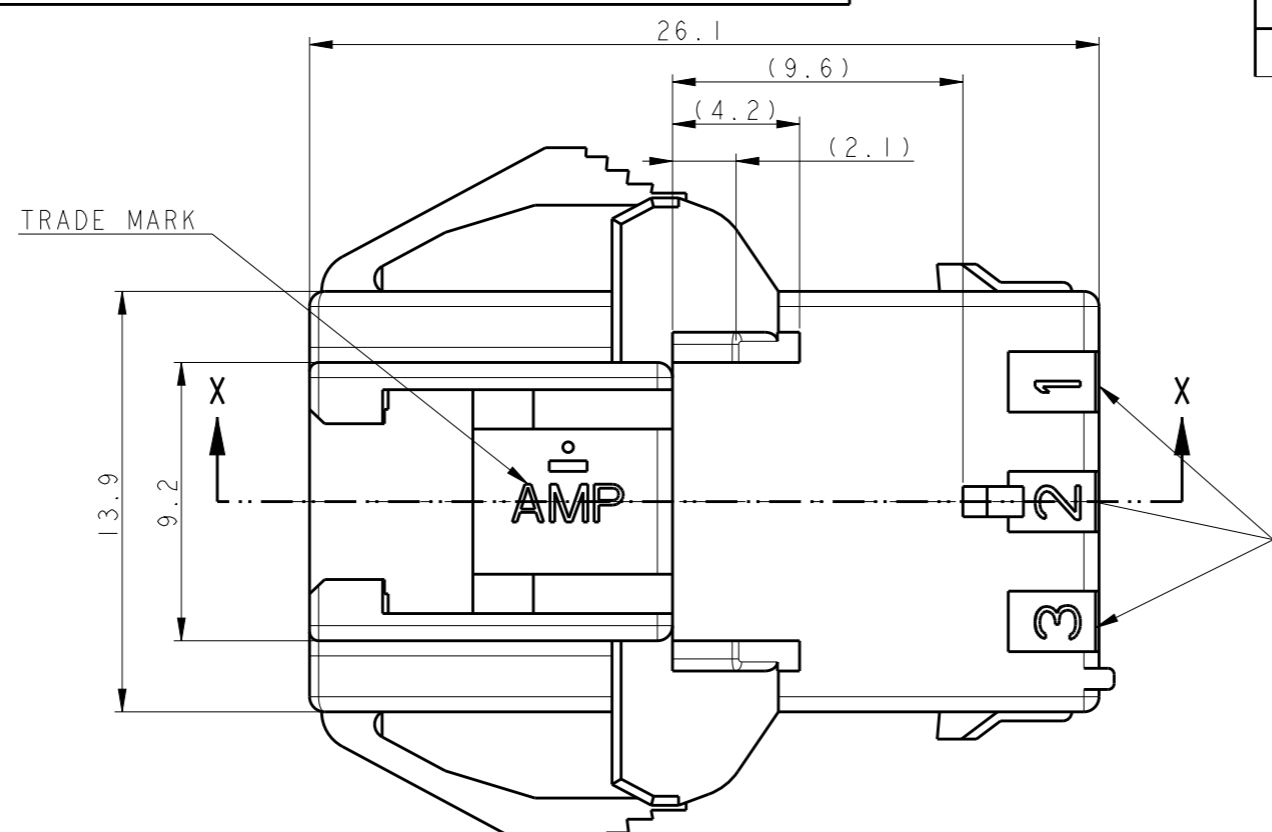
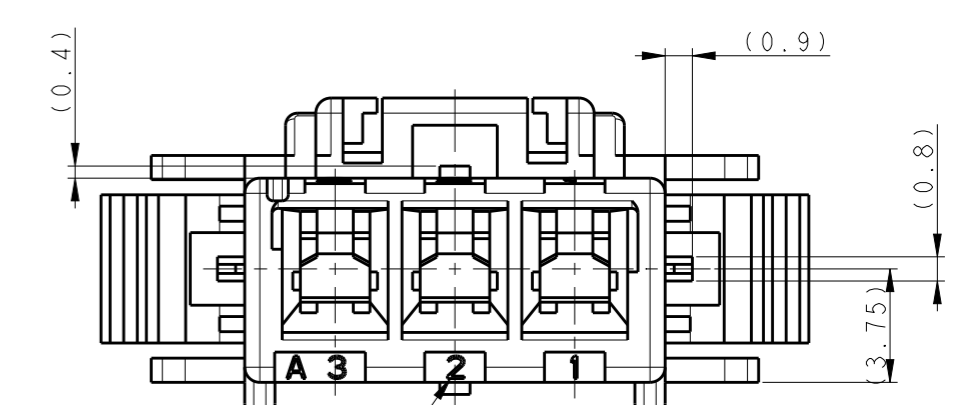
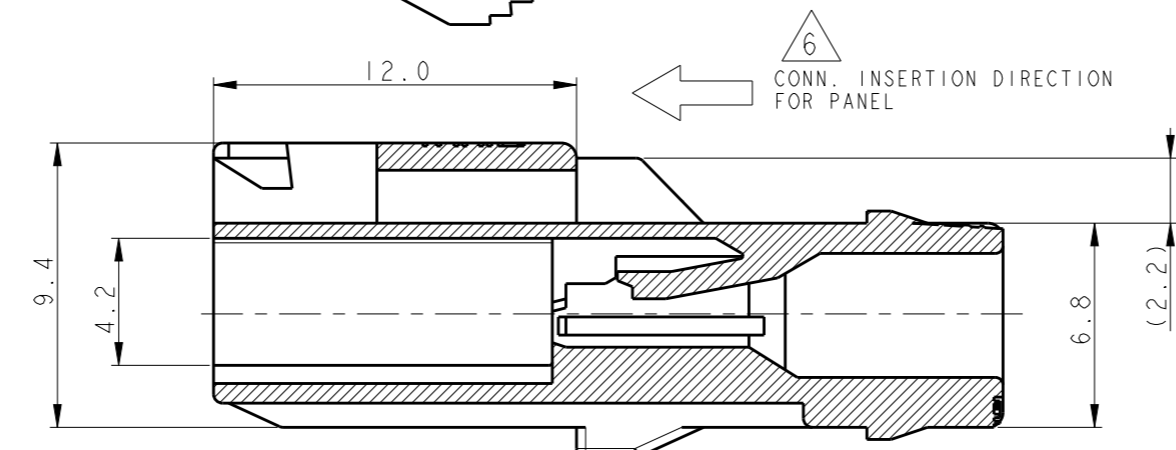
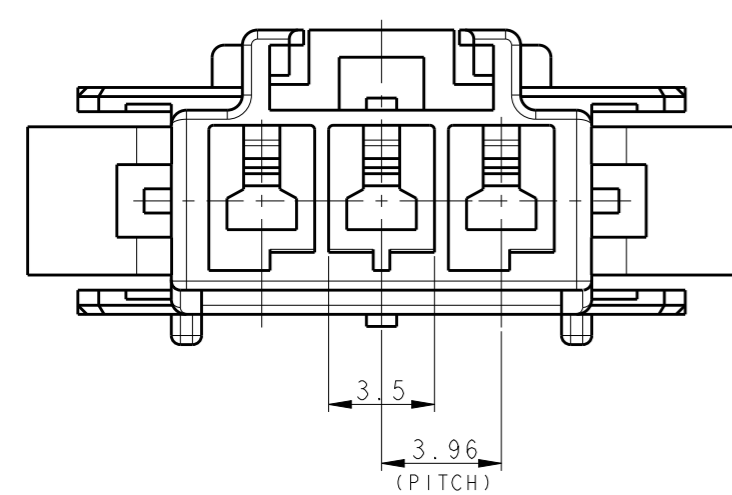

FIG 1.5
 RECOMMENDED PANEL OPENING DIMENSION
 TOLERANCES: ±0.13



- NOTE;
- THIS HOUSING ACCEPTS TAB TERMINAL:
 -TAB CONTACT: 177917-□ (AWG#16-#20)
 177916-□ (AWG#22-#26)
 - MATING CONN. P/N
 -PLUG HSG: 368571-□
 -REC CONTACT: 177915-□ (AWG#16-#20)
 : 177914-□ (AWG#22-#26)
 - APPLICABLE DOUBLE LOCK PLATE: 177919-1
 *IT SHOULD BE USED CERTAINLY WHEN CABLE ASS'Y
 - GENERAL TOLERANCES: ±0.3
 - APPLICATOIN PANEL THICKNESS: 0.8~2.0 (SEE FIG 1.)
 - INSERT CONN. FROM PRESS DIRECTION SIDE FOR METAL PANEL.
 - EDGE OF THICKNESS MAY MUST NOT ROUND FOR MOLDED PANEL.
 - MATERIAL: PA66 UL94V-0
 COMPLY WITH GLOW WIREREQUIREMENT FOR PARTS OF NON-METALLIC MATERIALSUPPORTING A CURRENT-CARRYING CONNECTION DETAILED IN IEC 60335-1, SECTION 30(GWT).

2005250-9	BLACK
2005250-6	BLUE
2005250-4	YELLOW
2005250-2	RED
2005250-1	NATURAL
P/N	COLOR

THIS DRAWING IS A CONTROLLED DOCUMENT.		DWN SC KIM		TE Connectivity	
DIMENSIONS: mm		CHK BW KANG			
TOLERANCES UNLESS OTHERWISE SPECIFIED:		APVD JK SONG		NAME PDL 3P CAP HSG 3.96mm P/M (GWT)	
0 PLC ±-		PRODUCT SPEC 108-5410		SIZE	
1 PLC ±-		APPLICATION SPEC 114-5175		CAGE CODE	
2 PLC ±-		WEIGHT -		DRAWING NO	
3 PLC ±-		CUSTOMER DRAWING		A300779	
4 PLC ±-		SCALE 4:1		SHEET 1 OF 1	
ANGLES ±-		REV B		DRAWING NO C-2005250	
MATERIAL		RESTRICTED TO		REV B	
FINISH		SCALE 4:1		SHEET 1 OF 1	
8		REV B		DRAWING NO C-2005250	