

© 1962 BY AMP INCORPORATED. ALL RIGHTS RESERVED. AMP PRODUCTS COVERED BY PATENTS AND/OR PATENTS PENDING. APPROVED PER GOVT CONTRACT NO.

LOCATION FOR AMP-TAB FEMALE CONTACT

CAVITY IDENTIFICATION ON P/N (1) 582585-1 ONLY.

REVISIONS					
ZONE	LTR	DESCRIPTION	DATE	APPROVED	
✓	5	REVISED PER 0600-3683-95	TA	10-95	JWARNER

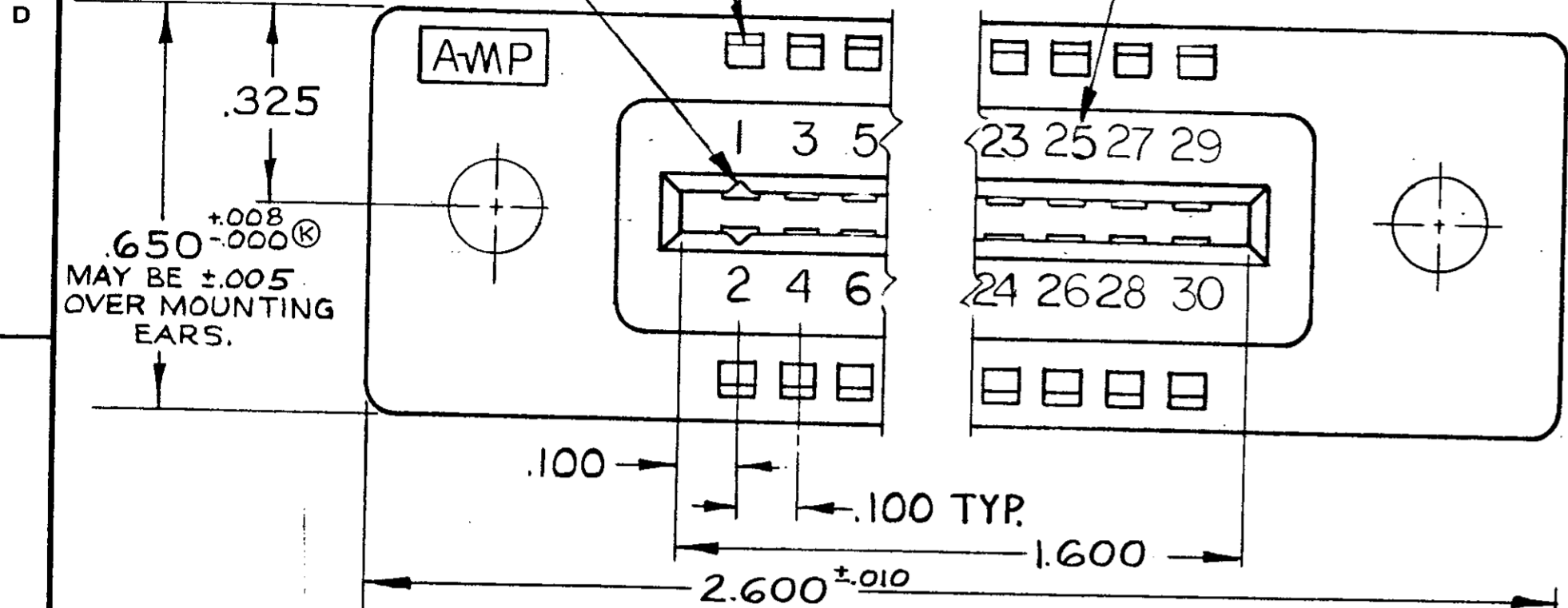

582585-1 1. AS SHOWN "J" DIA. HOLES = .128  
 OBSOLETE 582585-2 1. SAME AS 1 EXCEPT.  
 2. "J" DIA. HOLES = .156

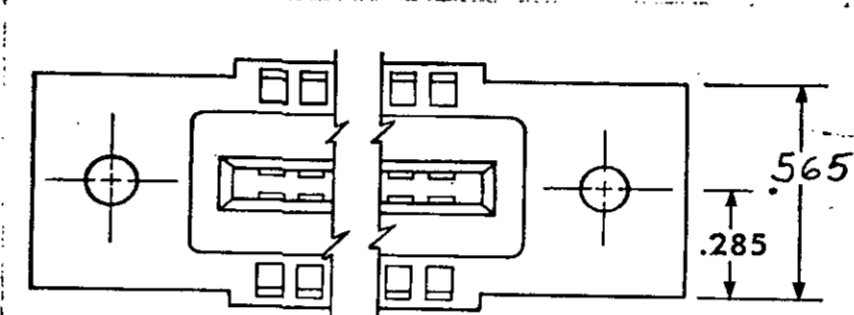

ALTERNATE MOUNTING EAR CONFIGURATION  $\Delta$

OBS  
~~582585-4 1. SAME AS -1 EXCEPT: FLOATING BUSHINGS~~  
 1) 582585-1 1. SAME AS -1 EXCEPT TO HAVE CAVITY IDENT. ON TOP SURFACE OF HOUSING.

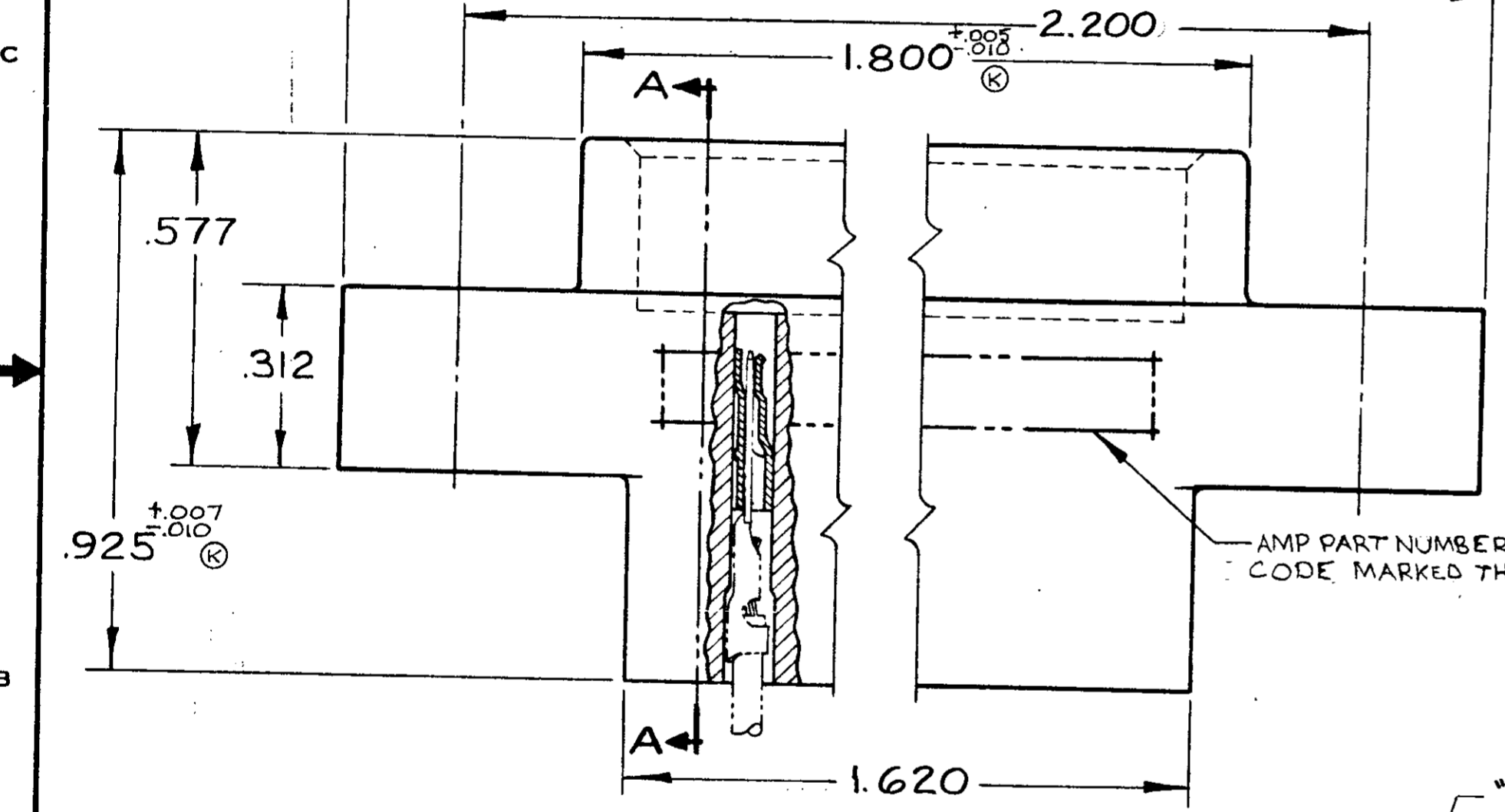

AMP PART NUMBER AND DATE CODE MARKED THIS AREA

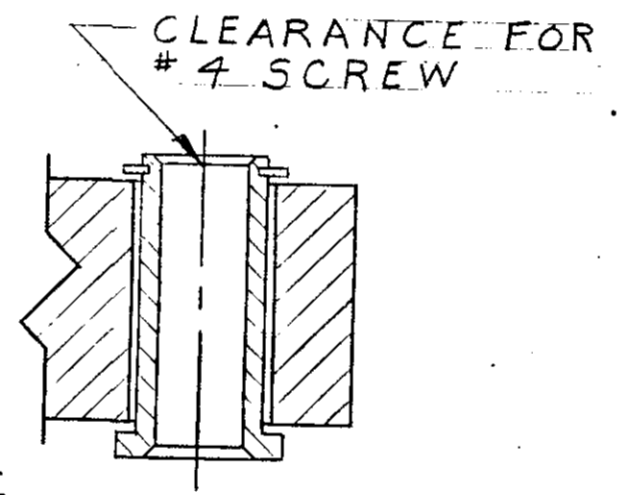

- 4 ONLY

±.003 (M)  
 "J" DIA. HOLES

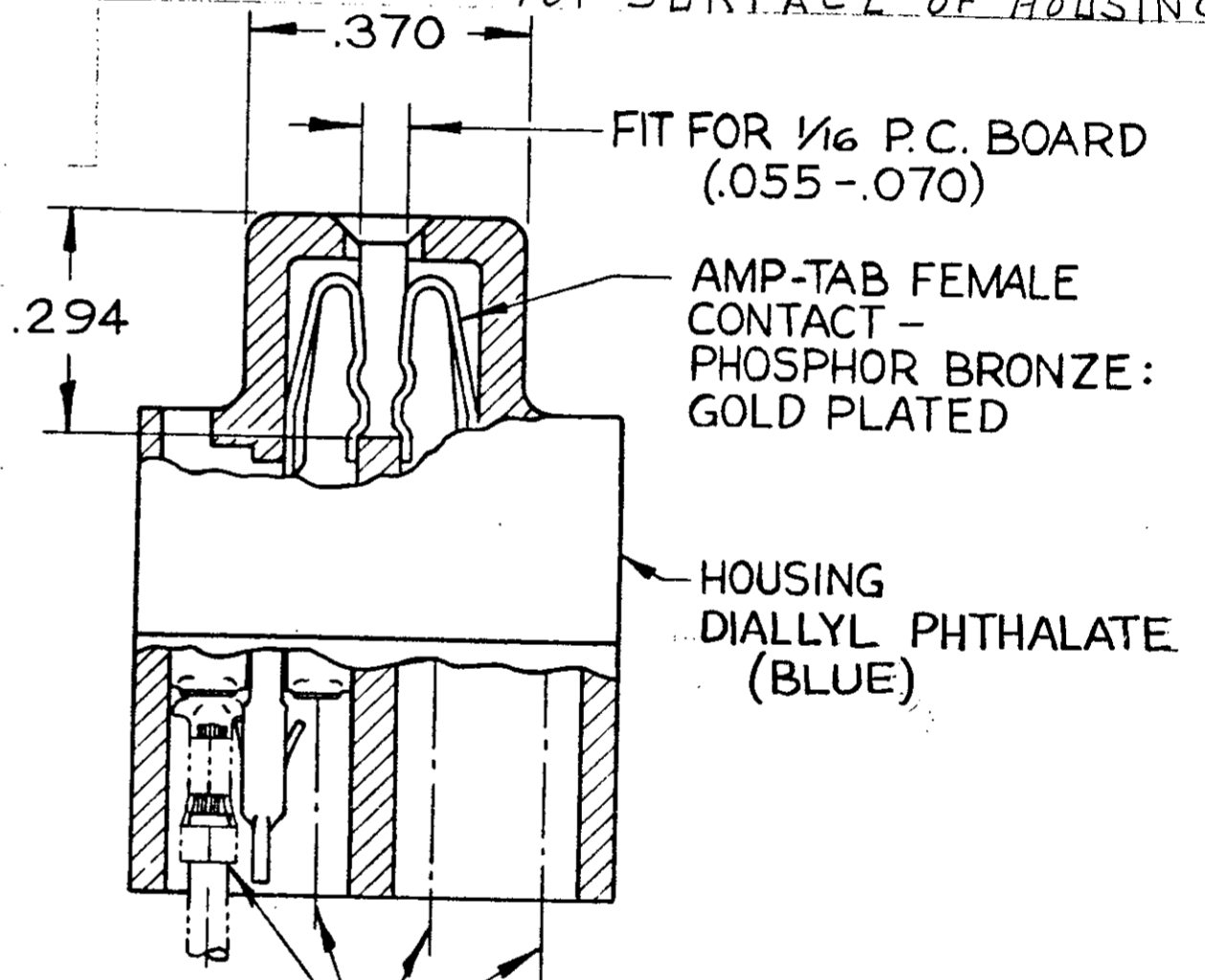

CONTACT #66143 OR #66144  
 (NOTE: MAX. WIRE SIZE #20)  
 (MUST BE ORDERED SEPARATELY)

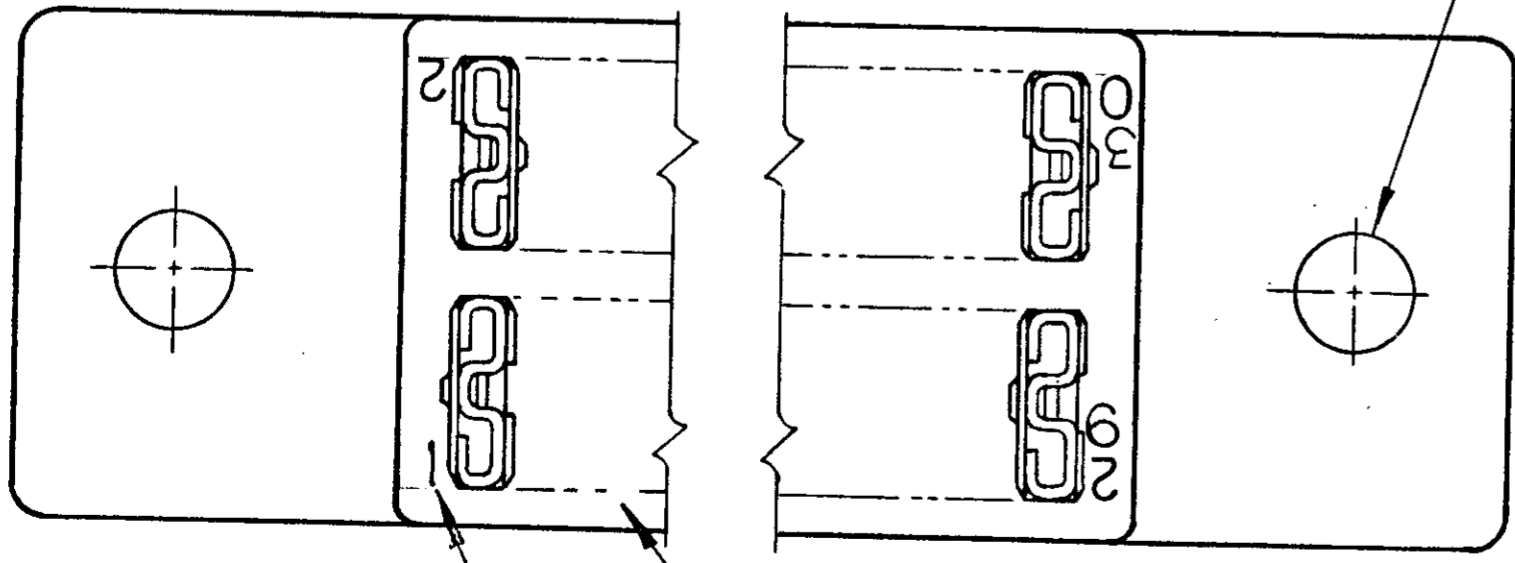

CIRCUIT CAVITY IDENTIFICATION MARKING PER MIL-C-21097

MARK FIRST 5 POSITIONS, NEXT 5 POSITIONS PLAIN

SECTION A-A

- $\Delta$  GROOVES FOR "ON CONTACT KEYING" AMP'S OPTION DEPENDING ON METHOD OF MANUFACTURE. FOR "ON CONTACT" KEYING USE KEYING PLUG P/N 583487-1. (MUST BE ORDERED SEPARATELY.)
- $\Delta$  MOUNTING EAR CONFIGURATION AMP'S OPTION DEPENDS ON METHOD OF MANUFACTURE.

UNLESS OTHERWISE SPECIFIED DIMENSIONS ARE IN INCHES TOLERANCES ON		CONTRACT NO.		AMP INCORPORATED HARRISBURG, PENNSYLVANIA	
FRACTIONS ±	DECIMALS ±.005	ANGLES ±	DR J. Asick	DATE 12-16-66	AMP TRADEMARK
MATERIAL SEE CALLOUT			CHK L. Burns	DATE 1-5-67	15- POSITION AMP-TAB CONNECTOR .100 CENTERS QUAD
HEAT TREAT —			APPD J. Kaufman	DATE 1-11-67	
FINISH SEE CALLOUT			DSGN APPD R. Showman	DATE 1/10/67	NUMBER 582585
OTHER APPD			SIZE C	CODE IDENT NO 00779	SCALE 4-1
			WT	CALC	ACTUAL
			SHEET		

AMP INFO	
LOC	PRINT/DIST
DF	FO

NUMBER 582585  
CUS. 582585