

NO.	DESCRIPTION	PART NO.	QTY	MATERIAL	DRW NO.	REMARKS
1	CONNECTOR	00 5036 006 XXX 862	500			
2	EMBOSSSED TAPE		1	POLYSTYRENE		
3	TOP COVER TAPE		1	POLYSTYRENE		
4	REEL		1	POLYSTYRENE		

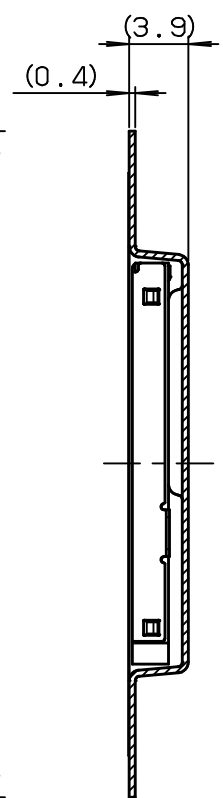

注 記 NOTE

- 1. 納入数量 : 500個/reel
QUANTITY : 500 ea/reel
- 2. 納入時のリール巻き方向
REELING DIRECTION
IN DELIVERY

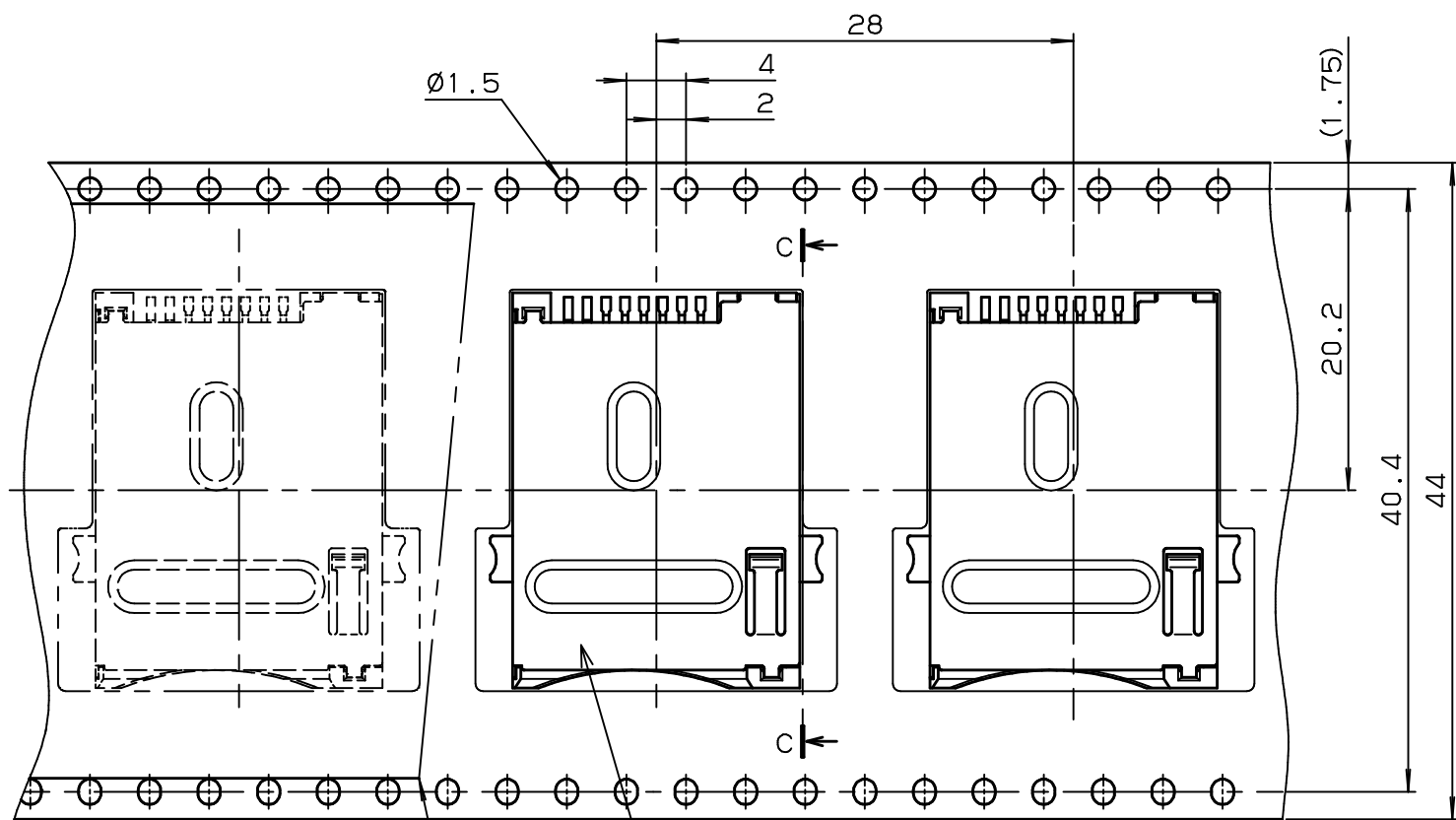
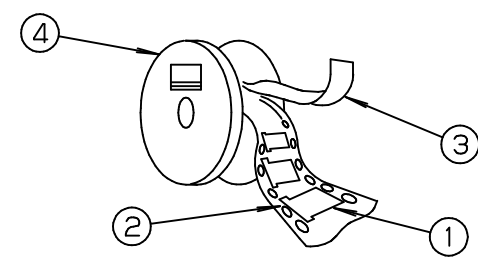

3. 引出し方向

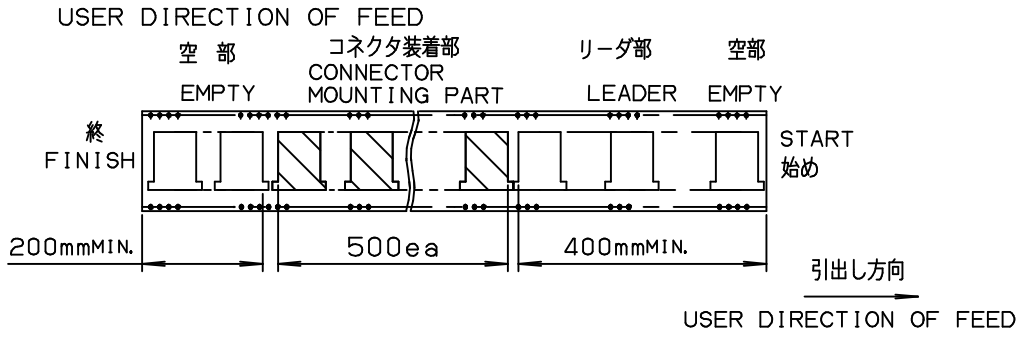

SECT. C-C

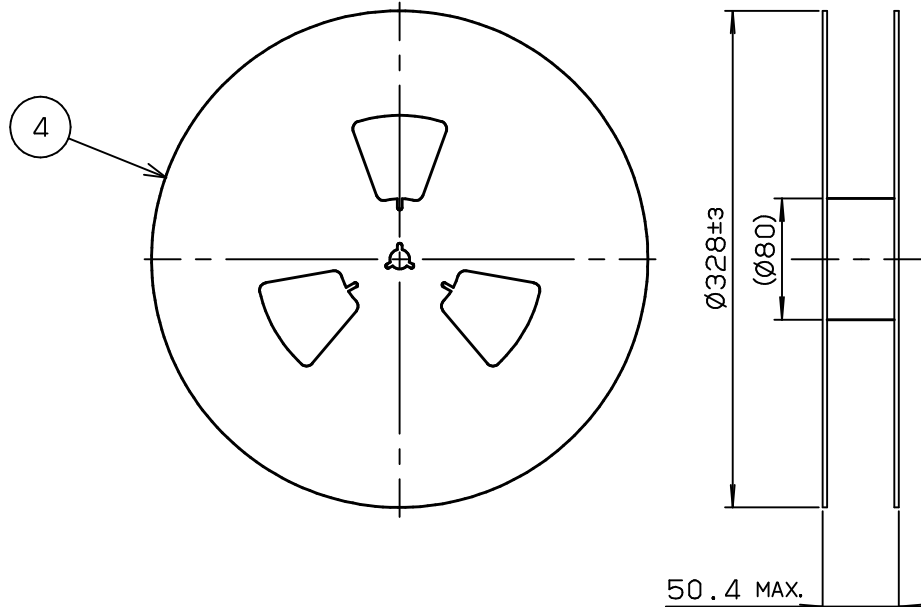

REEL DIMENSION (S=1/5)

ORDERING CODE 04 5036 006 XXX 862
 SERIES 5036:SERIES 5036
 NO. of CONT 006:6P
 VARIATION 1
 099:With BOSS (PITCH 15.54)
 100:With BOSS (PITCH 13.52)
 101:Without BOSS
 FINISH CODE
 862:UNDER COATED:Ni 1.5~2.5µm
 CONTACT AREA:Au0.5µm MIN
 TAIL AREA:SnPb 2~4µm (Sn:Pb=9:1)

TOLERANCE / 一般公差 (S)		PRODUCT SPEC / 製品規格							
X < 10	±0.2	UNIT	ANGLE	0	EDN-137	2-26-03			
10 ≤ X < 30	±0.25	mm	3RD	NO.	EDN/DCN	DATE	ISSUE	CHECKED	APPROVED
30 ≤ X	±0.3	SCALE	DATE	PART NAME / 品名					
ANGLE / 角度	±3°	2 / 1	2-26-03	SERIES 5036 TYPE S/E METAL SHELL SIM CONNECTOR ASSY SMT 44mm TAPING					
DRAWN	DESIGNED	CHECKED	APPROVED	PART NO. / 型番					
T. MORI	T. MORI			04 5036 006 XXX 862					

NO.	DESCRIPTION	PART NO.	QTY	MATERIAL	DRW NO.	REMARKS
1	INSULATOR		1	LCP	UL94-V0	
2	CONTACT		6	PHOS-BRONZE	CONT. AREA: Au TAIL: Sn-Pb	
3	C/D CONT UPPER		1	PHOS-BRONZE	CONT. AREA: Au TAIL: Sn-Pb	
4	C/D CONT LOWER		1	PHOS-BRONZE	CONT. AREA: Au TAIL: Sn-Pb	
5	SHELL		1	SUS		
6	COIL SPRING		1	SWP		
7	E/J BAR		1	LCP		
8	CUM BAR		1	SUS	UL94-V0	

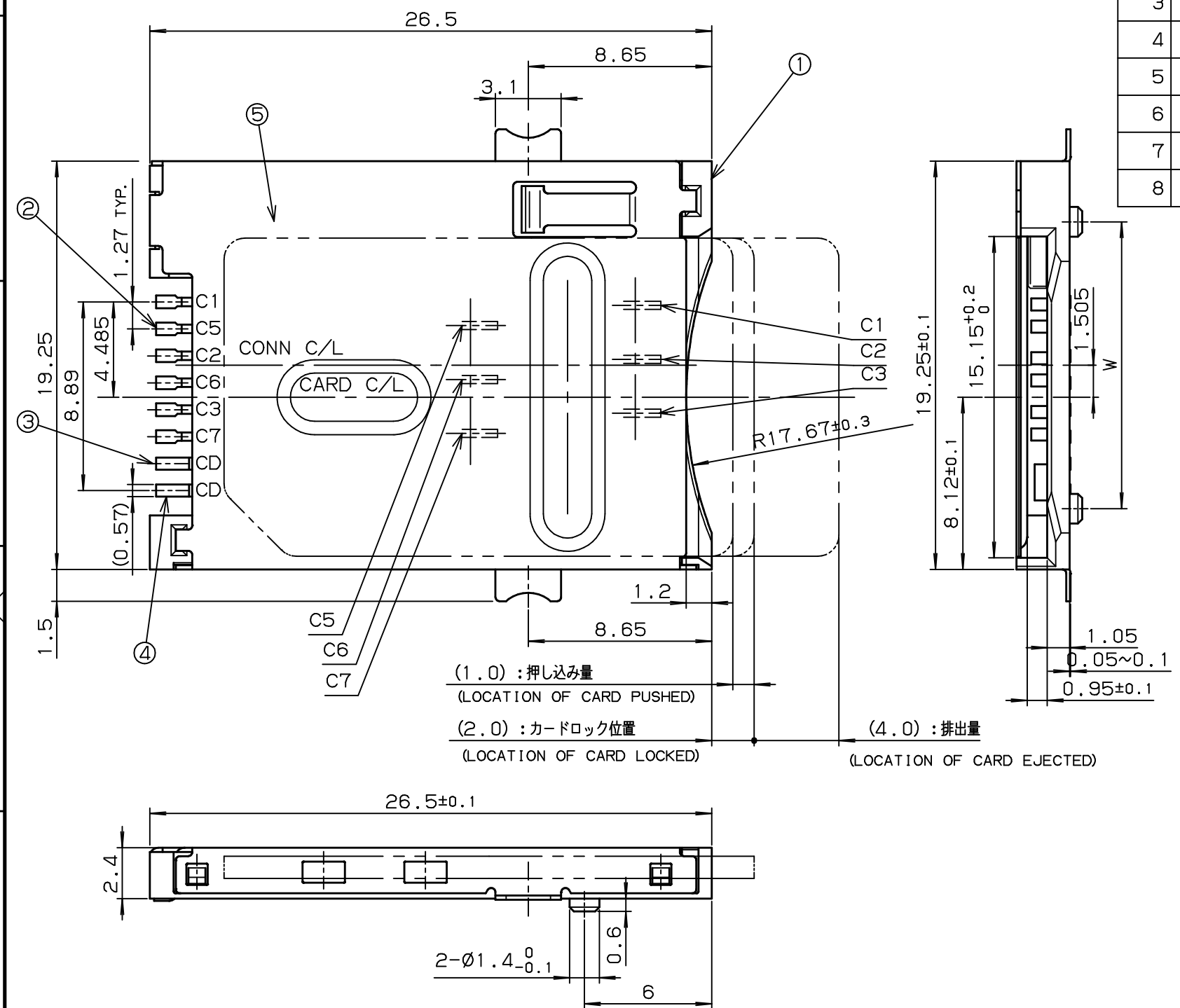

(1.0) : 押し込み量
(LOCATION OF CARD PUSHED)

(2.0) : カードロック位置
(LOCATION OF CARD LOCKED)

(4.0) : 排出量
(LOCATION OF CARD EJECTED)

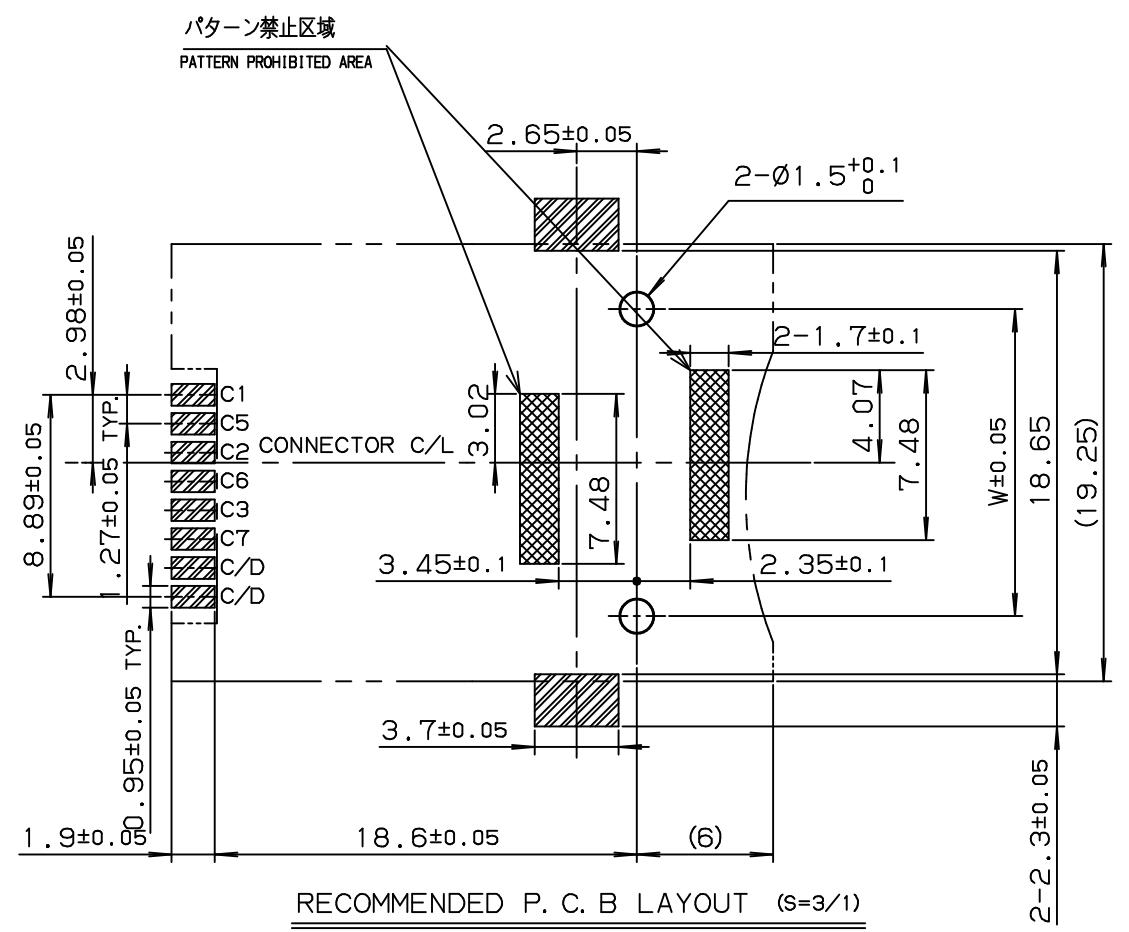

RECOMMENDED P. C. B LAYOUT (S=3/1)

ORDERING CODE 00 5036 006 XXX 862

SERIES 5036: SERIES 5036

NO. of CONT 006: 6P

VARIATION 1
099: With BOSS (W=15.54)
100: With BOSS (W=13.52)
101: Without BOSS

FINISH CODE 862: UNDER COATED: Ni 1.5~2.5μm
CONTACT AREA: Au 0.5μm MIN
TAIL AREA: SnPb 2~4μm (Sn:Pb=9:1)

注記 NOTES

- テールコプラナリティー: 0.1mmMAX.
COPLANARITY: 0.1mmMAX.
- 回路構成
CIRCUIT

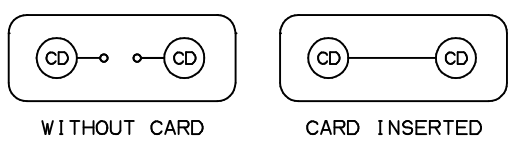

TOLERANCE / 一般公差 (S)		PRODUCT SPEC / 製品規格							
X < 10	±0.2	UNIT	ANGLE	O EDN-137		2-26-03			
10 ≤ X < 30	±0.25	mm	3RD	NO.	EDN/DCN	DATE	ISSUE	CHECKED	APPROVED
30 ≤ X	±0.3			PART NAME / 品名					
ANGLE / 角度 ±3°		SCALE	DATE	SERIES 5036 SIM CONNECTOR ASSY SMT					
DRAWN	DESIGNED	CHECKED	APPROVED	PART NO. / 型番					
T. MORI	T. MORI			00 5036 006 XXX 862					
KYOCERA KYOCERA ELCO CORPORATION				DWG NO. / 図番		BJS 5036009		SHEET / REV	
								1/1 0	