

PART NAME: HANDLE

SCALE: 1:1

DATE: 12/7/16

DR. BY: JAM



P/N: 4571B0

THIS DRAWING IS THE PROPERTY OF DAVIES MOLDING COMPANY, IS SUBMITTED SOLELY AS A DESIGN OR ENGINEERING PROJECT WE ACCEPT NO RESPONSIBILITY WHATSOEVER FOR THE PRACTICAL APPLICATION OF THE PIECES MADE TO THIS DESIGN.

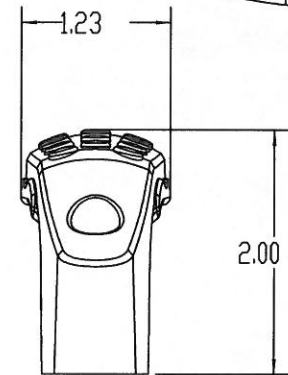
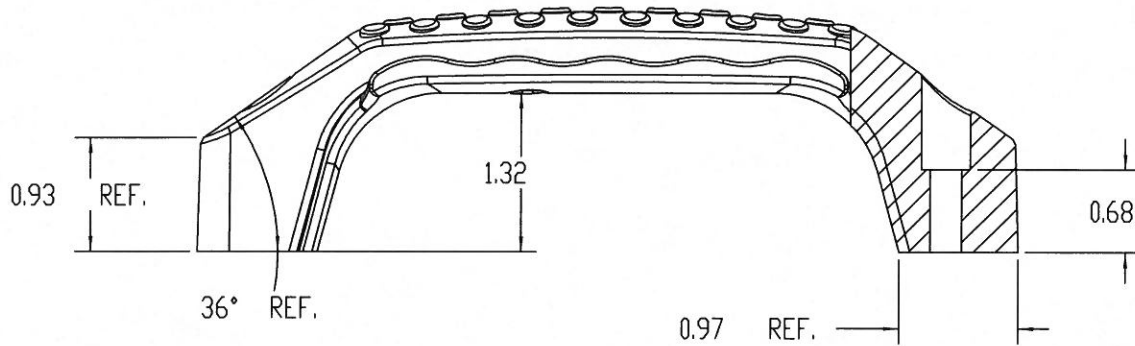
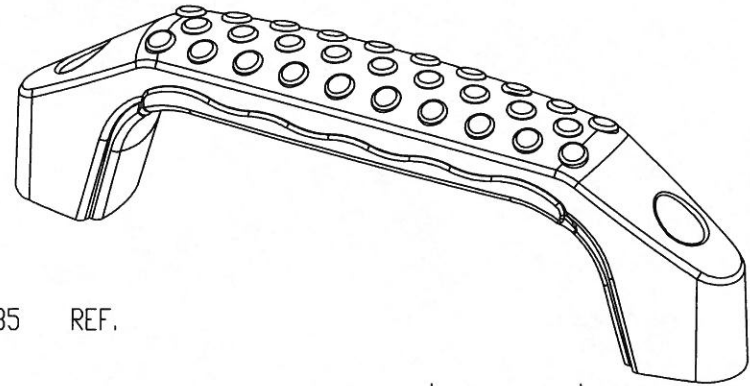
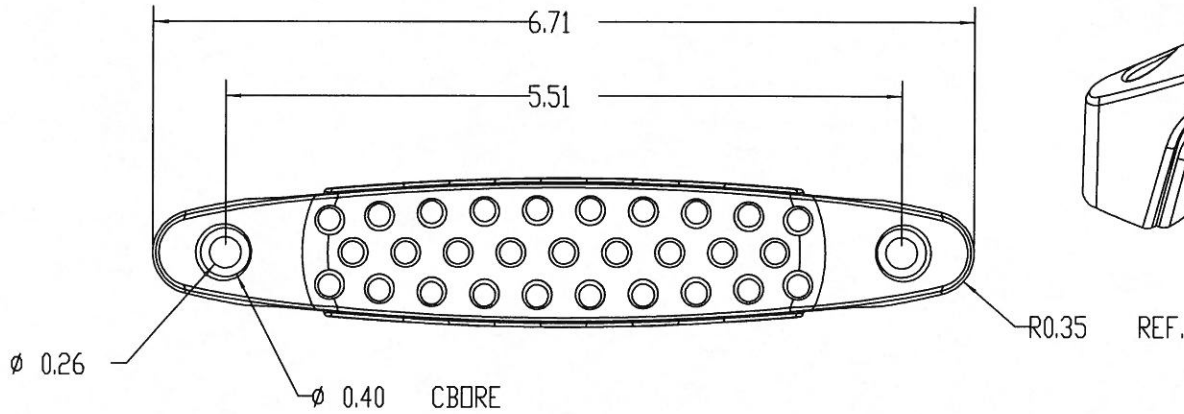

SUBSTRATE MATERIAL: 33% GLASS FILLED NYLON

COLOR: BLACK

OVERMOLD MATERIAL: TPE

COLOR: ORANGE

TOLERANCES: UNLESS OTHERWISE SPECIFIED	DO NOT SCALE DRAWING				
DECIMALS: X.XXX ± .005 X.XX ± .015	MM: X.XX ± 0.15MM X.X ± 0.4MM				
FRACTIONS ± 1/64	ANG. ± 1°	CHANGES			