

PART NUMBER	REV	FIRST USED
680379-1	B	122500-1
680379-2	B	565435-5
680379-3	B	354500-1

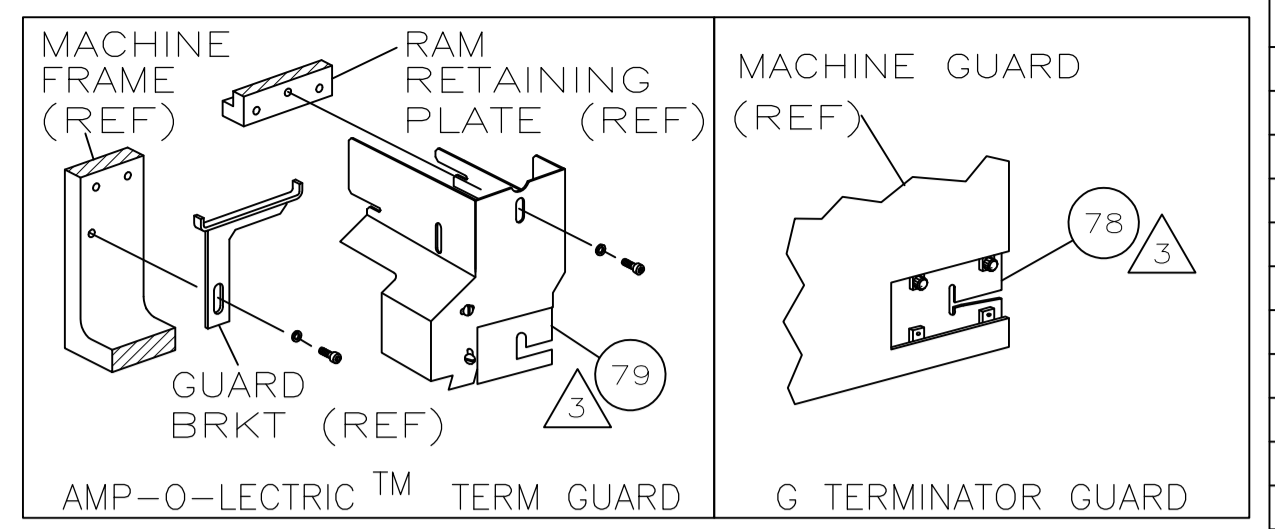

TERMINAL NAME: PIN & SOCKET			
		CRIMPING DATA	
AMP	MFG P/N	PAD LTR	CRIMP HEIGHT
286527	E7EB-14461-HB	A	.059 ±.002 [1.5 ±0.05mm]
286528	E7EB-14488-SA	B	△.057 ±.002 [1.45 ±0.05mm]
		C	.055 ±.002 [1.4 ±0.05mm]
		D	.053 ±.002 [1.35 ±0.05mm]
			WIRE SIZE
			18
			18
			18
			18
			18
			18
			18
WIRE STRIP LENGTH	TERM APPL SPEC	FEED	APPL INSTRUCTION
-	NONE	.520	408-8040
			SET UP GAGE
			LAYOUT
			458637-1
			L1836

LOC	DIST	REVISONS	
A	66	REV	DESCRIPTION
		B	ECR-08-008601
		DATE	OWN
		4-2008	MY
		APVD	GB

REV	DESCRIPTION	DATE	OWN
-1	LEADMAKER	MECH POST FEED	
-2	BENCH MODEL K	MECH PRE FEED	
-3	BENCH MODEL G	MECH PRE FEED	

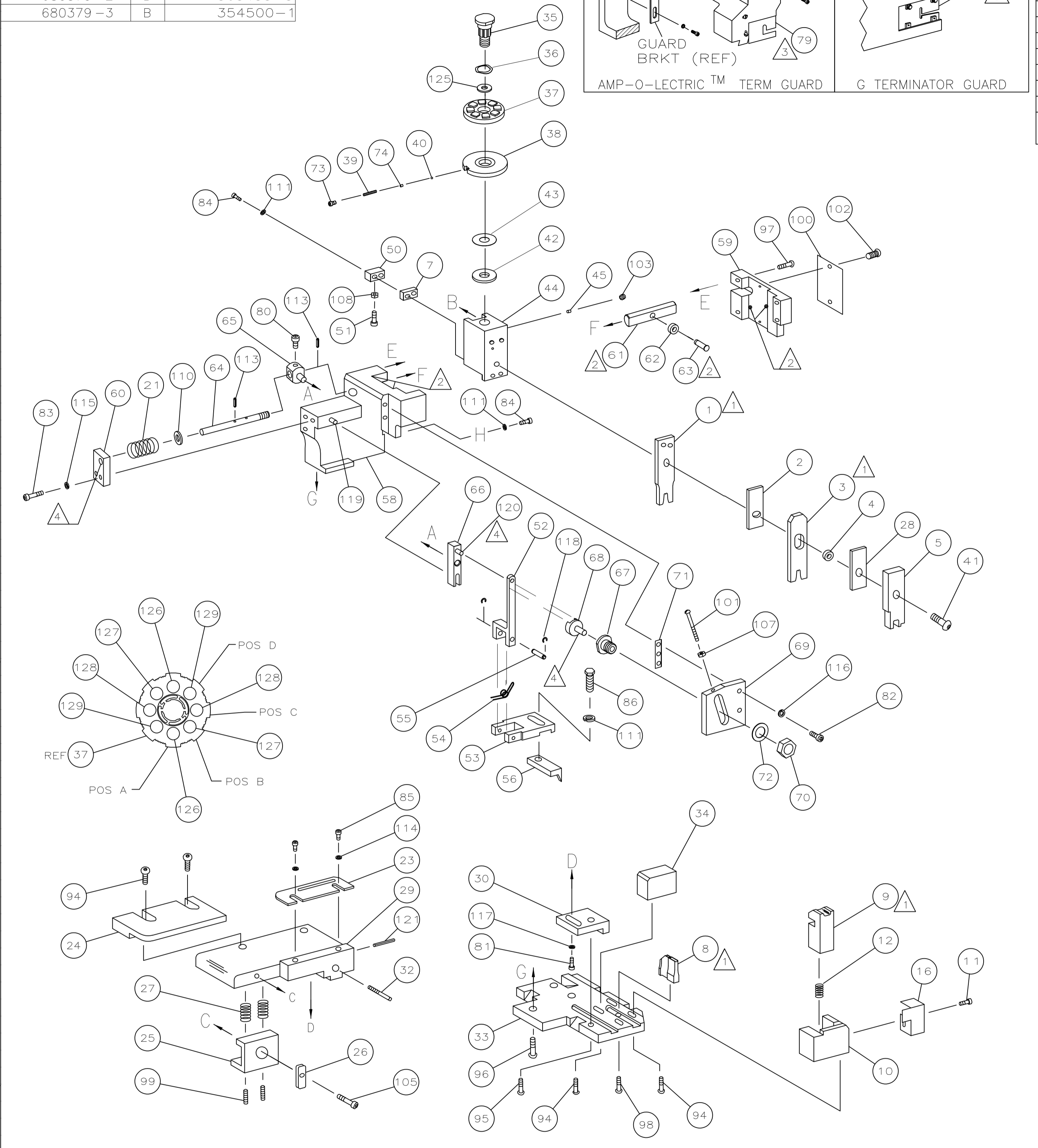

QTY REQD PER ASSY	PART NO	DESCRIPTION	ITEM NO
2	2-354779-2	PIN, WIRE DISC (.3100)D	129
2	2-354779-8	PIN, WIRE DISC (.3080)C	128
2	2-354779-4	PIN, WIRE DISC (.3060)B	127
2	2-354779-8	PIN, WIRE DISC (.3030)A	126
1	1-986950-1	WASHER, FLAT PRECISION	125
1	1-217238-1	GENERAL INSTRUCTION PACKAGE	124
1	1-4088040	SF APPL INST 408-8040	123
1	4-21028-0	PIN,SLT SPR(Φ.093x.75)ST GDE PL	122
REF	REF	PIN,DOWEL(Φ.187x.50)LEVER	120
REF	REF	PIN,DOWEL(Φ.187x1.25)HOUSING	119
REF	REF	RING,RET "C"(Φ.187)FD FING PIN	118
1	1-21024-5	WASHER, LOCK(#10)ADJ BLOCK	117
REF	REF	WASHER,LOCK(#10)ADJ PLATE	116
REF	REF	WASHER,LOCK(#10)FEED GDE ROD	115
2	2-21024-2	WASHER,LOCK(#4)FRONT STP GUIDE	114
REF	REF	PIN,SLT SPR(Φ.125x.50)ADJ ROD	113
4	4-21024-4	WASHER,LOCK(#8)STRIPPER	111
REF	REF	WASHER,FLAT(Φ5/16)SCREW ADJ	110
1	1-21018-5	NUT,HEX(NO.6)HOLDDOWN	108
REF	REF	NUT,HEX(6-32)FEED ADJ	107
1	1-22353-8	SCR,SHLD(Φ.187x.25)DRAG LEVER	105
1	1-21009-2	SCR,SKT SET(1/4-20x.25 LW)RAM	103
2	2-21017-2	SCR,DRIVE(#2x.19)ID PLATE	102
REF	REF	SCR,PAN HD(6-32x1.50)FEED ADJ	101
1	1-461264-1	PLATE, IDENTIFICATION	100
2	2-21006-6	SCR,SET(10-32x.75)DRAG	99
1	1-22733-8	SCR,BHC(8-32x.38 LW)ANVIL	98
REF	REF	SCR,BHC(10-32x.75)CAP	97
REF	REF	SCR,BHC(1/4-20x.62)HOUSING	96
REF	REF	SCR,BHC(10-32x.50)SG ADJ BLOCK	95
6	6-21002-2	SCR,BHC(8-32x.50)TERM H DWN	94
1	1-21002-7	SCR,BHC(6-32x.38)CAM	91
1	2-22603-0	SCR,HEX HD(8-32x.31)FEED FINGER	86
2	2-21000-3	SCR,SHC(4-40x.25)F ST GUIDE	85
3	3-21000-7	SCR,SHC(8-32x.50)STRIPPER	84
REF	REF	SCR,SHC(10-32x.75)FEED ROD GD	83
REF	REF	SCR,SHC(10-32x.62)FD ADJ BLK	82
1	1-21000-4	SCR,SHC(10-32x.38)SG ADJ BL	81
REF	REF	SCR,SHC(10-32x.38)PIVOT BLK	80
-	REF	GUARD, WINDOW	79
REF	REF	INSERT, GUARD	78
1	690603-1	SPRING, ASSIST	74
1	1-23030-1	SCR,SHC(6-32x.25 SL)JNS DISC	73
REF	REF	WASHER, SPECIAL	72
REF	REF	SPACER	71
-3	-2	-1	U/M
PARTS LIST			

REF	REF	REF	REF	REF	DESCRIPTION	QTY
				22594-8	NUT,HEX(1/2-20)	70
				240628-1	PLATE, ADJUSTMENT	69
				240626-1	SHAFT, PIVOT	68
				240633-1	BUSHING	67
				455680-1	LEVER, INTERMEDIATE	66
				240629-1	BLOCK, PIVOT	65
				240632-2	SCREW, ADJ FEED ROD	64
				240659-3	PIN, CAM ROLLER	63
				240658-1	ROLLER, CAM	62
				454398-2	ROD, FEED	61
				454178-1	GUIDE, FEED ROD	60
				454220-1	CAP, RAM	59
				454485-1	HOUSING	58
				1-694433-6	PAWL, FEED	57
				240624-1	PIN, FEED FINGER	55
				691499-1	SPRING, FEED FINGER	54
				690541-1	HOLDER, FEED FINGER	53
				455679-2	LEVER, TERMINAL FEED ARM	52
1	1	1	-	811242-2	BUMPER, HOLDDOWN	51
1	1	1	-	690753-1	SPACER, TONKER	50
1	-	-	-	690602-6	CAM, PRE-FEED 1 5/8 ST	49
-	1	-	-	690602-5	CAM, PRE-FEED 1 1/8 ST	48
-	-	1	-	690501-4	CAM, POST-FEED 1 5/8 ST	47
1	1	1	-	459456-2	APPLICATOR, BASIC (SUBASSY)	46
1	1	1	-	690191-1	PLUG, NYLON	45
1	1	1	-	455673-1	RAM	44
1	1	1	-	690125-1	WASHER, LAMINATED	43
1	1	1	-	690124-1	WASHER, RAM	42
1	1	1	-	7-21002-9	BOLT, CRIMPER(5/16x1.00)	41
1	1	1	-	23241-6	BALL, STEEL	40
1	1	1	-	690170-1	SPRING, COMPRESSION	39
1	1	1	-	690142-1	DISC, INSULATION	38
1	1	1	-	354777-1	WIRE DISC, PLASTIC	37
1	1	1	-	22480-5	WASHER, SPRING	36
1	1	1	-	690212-1	POST, RAM	35
1	1	1	-	690786-6	SUPPORT, TERMINAL	34
REF	REF	REF	-	455675-1	PLATE, BASE	33
1	1	1	-	690432-3	SCREW, ADJUSTMENT	32
REF	REF	REF	-	455689-1	BLOCK, STRIP GUIDE ADJ	30
1	1	1	-	3-458144-3	PLATE, STRIP GUIDE	29
1	1	1	-	2-455888-7	SPACER, FRONT SHEAR DEP	28
2	2	2	-	1-22284-0	SPRING, DRAG	27
1	1	1	-	356835-1	LEVER, DRAG RELEASE	26
1	1	1	-	240792-1	DRAG, TERMINAL	25
1	1	1	-	5-690504-1	GUIDE, STRIP (REAR)	24
1	1	1	-	690438-1	GUIDE, STRIP (FRONT)	23
-	-	1	-	690472-2	STRIPPER	22
REF	REF	REF	-	4-22284-9	SPRING, FEED RETURN	21
1	1	-	-	691353-1	STRIPPER	20
1	1	1	-	318563-1	GUARD, CHIP, FRONT	16
1	1	1	-	3-22280-3	SPRING, SHEAR	12
1	1	1	-	690461-1	STOP, SHEAR	11
1	1	1	-	690459-1	HOLDER, SHEAR (FRONT)	10
1	1	1	-	454276-2	SHEAR, FLOAT (FRONT)	9
1	1	1	-	662186-3	ANVIL	8
1	1	1	-	1-240641-7	SPACER, DEPRESSOR (REAR)	7
1	1	1	-	1-455889-4	DEPRESSOR, SHEAR (FRONT)	5
1	1	1	-	1-238011-0	SPACER, BLOCK CRIMPER	4
1	1	1	-	9-456135-1	CRIMPER, INSULATION	3
1	1	1	-	1-455888-0	SPACER, CRIMPER	2
1	1	1	-	2-456405-9	CRIMPER, WIRE	1
-3	-2	-1	U/M	PART NO	DESCRIPTION	ITEM NO

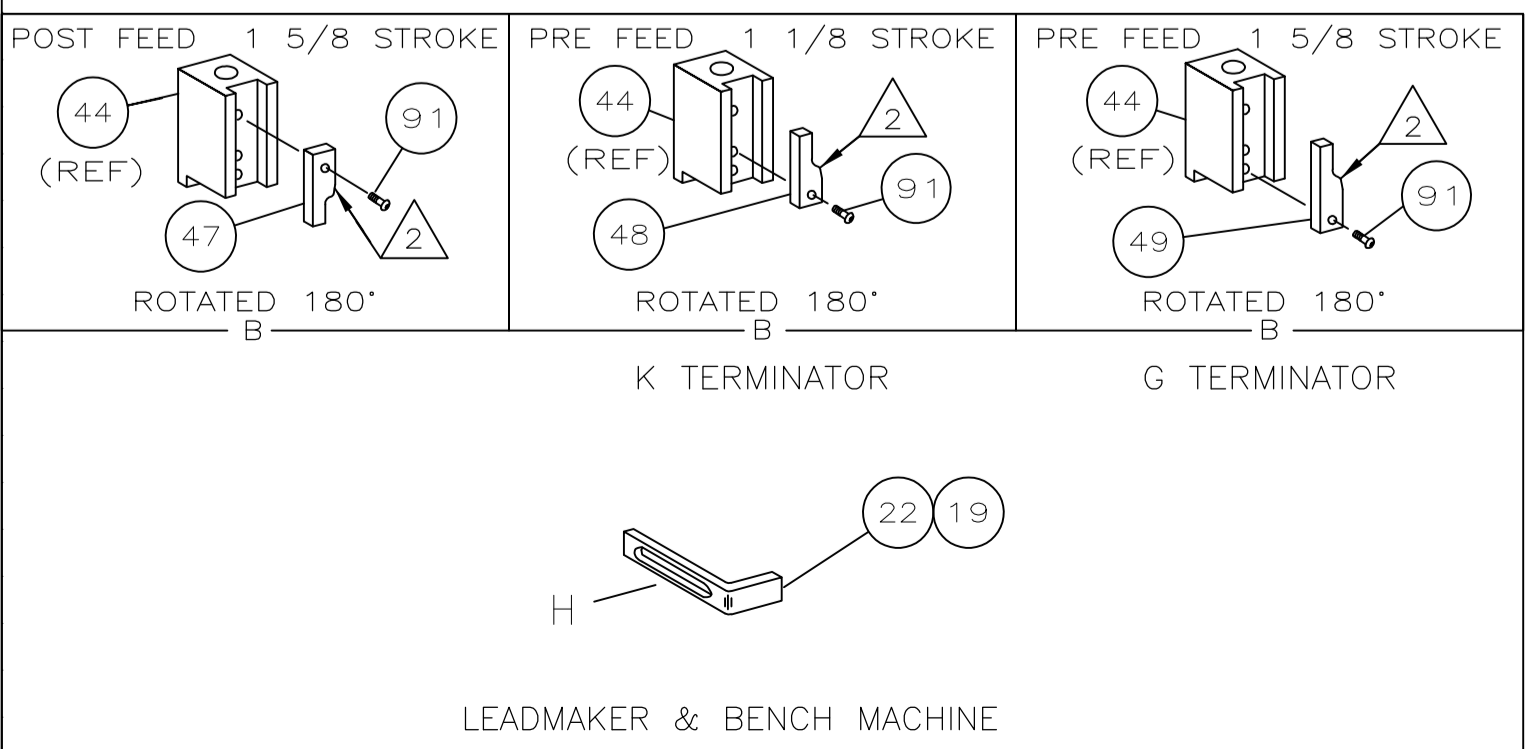

- 1 RECOMMENDED SPARE PARTS.
- 2 GREASE LIGHTLY.
- 3 GUARD MUST BE IN PLACE WHEN OPERATING APPLICATOR IN A BENCH MACHINE.
- 4 LUBRICATE DAILY USING NO. 20 MACHINE OIL.
- 5. ITEMS WITH QTY OF REF SPECIFIED (EXCEPT ITEMS 78 AND 79) ARE USED ON ITEM 46.
- 6 RECOMMENDED PER FORD SPEC
- 7 FEED IN SLOT