

STRAIGHT MALE RECEPTACLE FOR PCB
SNAP TYPE - SOLDER LEGS

R222.M00.080

Series : SMP-MAX

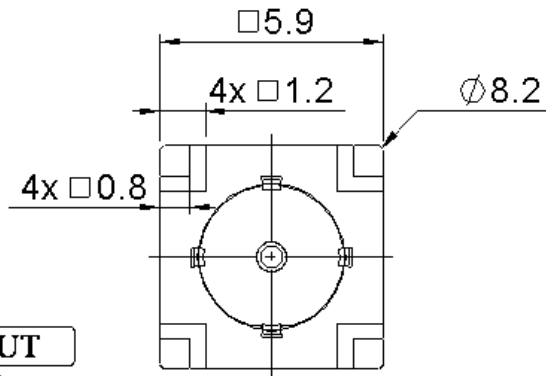

PANEL CUT OUT

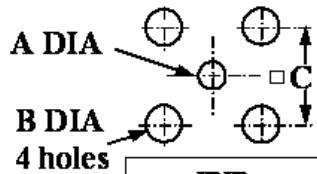

	mm	
	Maxi	mini
A	1.2	1.1
B	1.4	1.3
C	5.13	5.03

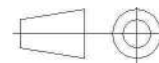
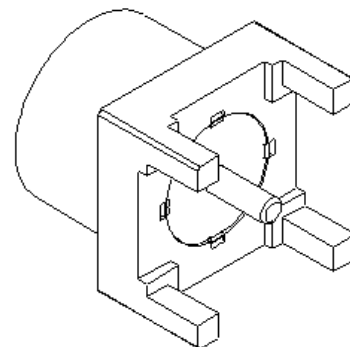
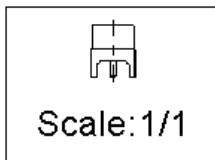
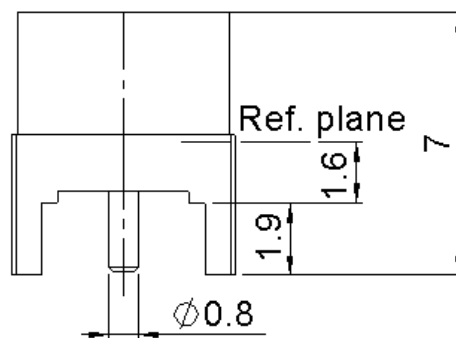

All dimensions are in mm.

COMPONENTS	MATERIALS	PLATING (µm)
BODY	BRASS	NPGR
CENTER CONTACT	BRASS	NPGR
OUTER CONTACT		
INSULATOR	PTFE/LCP/PEEK	
GASKET		
OTHERS PARTS		
-	-	-
-	-	-

Issue : 1245 C

In the effort to improve our products, we reserve the right to make changes judged to be necessary.



STRAIGHT MALE RECEPTACLE FOR PCB

R222.M00.080

SNAP TYPE - SOLDER LEGS

Series : **SMP-MAX**

PACKAGING

SPECIFICATION

Standard	Unit	Other
100	'W' option	Contact us

ELECTRICAL CHARACTERISTICS

ENVIRONMENTAL

Impedance	50	Ω
Frequency	0-6	GHz
VSWR	1.04* + 0,0200	x F(GHz) Maxi
Insertion loss	0.05*	\sqrt{F} (GHz) dB Maxi
RF leakage	- (NA)	- F(GHz)) dB Maxi
Voltage rating	335	Veff Maxi
Dielectric withstanding voltage	1000	Veff mini
Insulation resistance	5000	M Ω mini

Operating temperature	-55/+165	$^{\circ}$ C
Hermetic seal	NA	Atm.cm3/s
Panel leakage	NA	

OTHER CHARACTERISTICS

Assembly instruction

Others :

*Coaxial Transmission Line Only

Power handling (typical) :

>300W@2.7GHz at 25 $^{\circ}$ C; >200W@2.7GHz at 85 $^{\circ}$ C

MECHANICAL CHARACTERISTICS

Center contact retention		
Axial force – Mating end	7	N mini
Axial force – Opposite end	7	N mini
Torque	NA	N.cm mini
Recommended torque		
Mating	NA	N.cm
Panel nut	NA	N.cm
Mating life	100	Cycles mini
Weight	0,7220	g

Issue : 1245 C

In the effort to improve our products, we reserve the right to make changes judged to be necessary.

