

REV.	DATE	DESCRIPTION
NC	09/29/99	INITIAL RELEASE
A	10/10/07	UPDATE DRAWING FORMAT

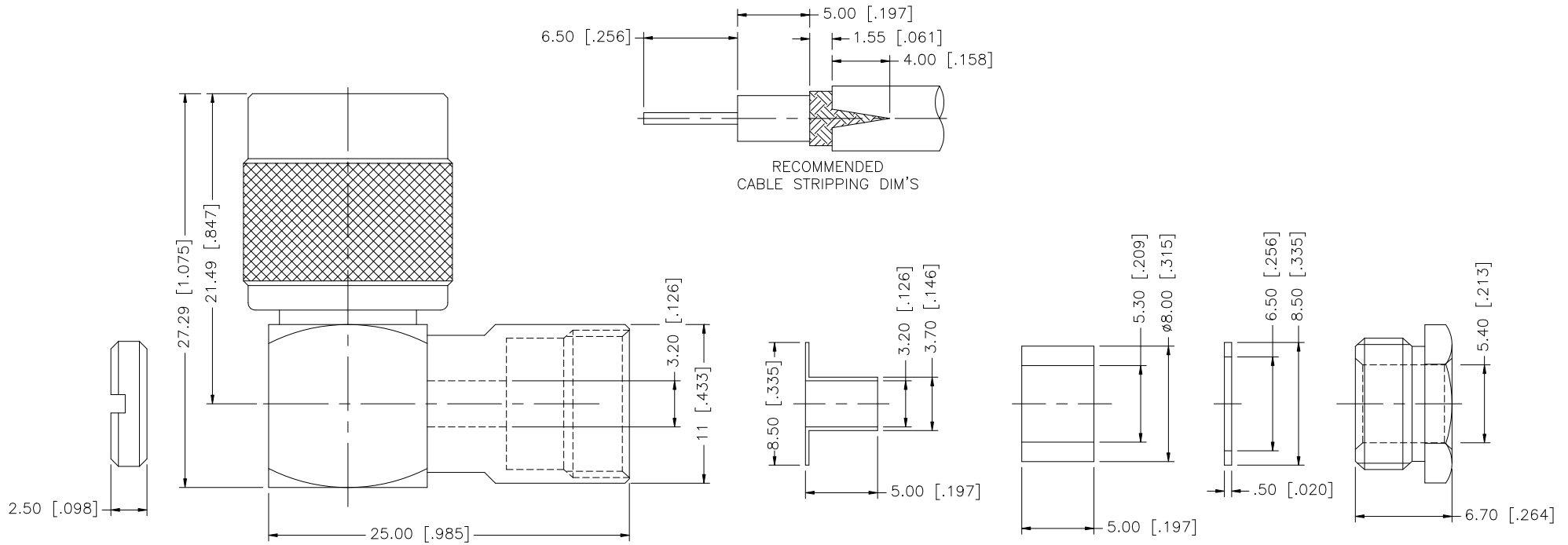

DESCRIPTION	MATERIAL	FINISH	QTY
8 COVER	BRASS	NICKEL	1
7 HEX NUT	BRASS	NICKEL	1
6 WASHER	BRASS	NICKEL	1
5 GASKET	SILICONE	RED	1
4 TOP HAT	BRASS	NICKEL	1
3 CONTACT PIN	BRASS	GOLD	1
2 INSULATOR	DELTRIN	NATURAL	1
1 BODY	BRASS	NICKEL	1

UNLESS OTHERWISE SPECIFIED DIMENSIONS ARE IN MILLIMETERS. DIMENSIONS IN [] ARE IN INCHES AND FOR CUSTOMER REFERENCE ONLY.

UNLESS OTHERWISE SPECIFIED TOLERANCES FOR MILLIMETERS ARE:
0.5 - 8mm ± 0.20mm
8 - 30mm ± 0.40mm
30 - 120mm ± 0.50mm

UNLESS OTHERWISE SPECIFIED TOLERANCES FOR INCHES ARE:
.020 - .315 ± 0.007"
.315 - 1.180 ± 0.015"
1.180 - 4.724 ± 0.020"

DO NOT SCALE DRAWING

APPROVALS	DATE
DRAWN G.R.S.	10/10/07
CHECKED	
ISSUED	
SHEET 1 OF 1	
CAD FILE	C:/122/122286.DWG

Amphenol Connex

PART DESCRIPTION
TNC R/A CLAMP PLUG
(FOR RG58/U, 141/U, 223/U, 142/U, 400/U CABLE)

PART NO.
122286

DWG. NO.	122286.DWG	REV.	A	SIZE	A	SCALE	NA
----------	------------	------	---	------	---	-------	----