



INTERNATIONAL HEADQUARTERS
20 Willow Springs Circle, York, Pa. 17402, (717) 767-6511 FAX: (717) 764-0839
Web site- <http://www.redlion-controls.com> E-mail- sales@redlion-controls.com

EUROPEAN HEADQUARTERS
892 Plymouth Road, Slough, Berkshire SL1 4LP
ENGLAND +44 1753 696888 FAX: +44 1753 696339

MODEL IMT - APOLLO INTELLIGENT THERMOCOUPLE METER

- USER PROGRAMMABLE T/C TYPE (T,E,J,K,R,S,B,N or mV SCALE)
- SELECTABLE °F OR °C WITH 0.1 OR 1 DEGREE DISPLAY RESOLUTION
- STATE OF THE ART DIGITAL ELECTRONICS FOR GREATER ACCURACY AND RELIABILITY
- FULL 6-DIGIT, HIGH VISIBILITY, 0.56" (14.2 mm) HIGH RED LED DISPLAY
- PROGRAMMABLE FRONT PANEL LOCK-OUT MENU
- PROGRAMMABLE TEMPERATURE OFFSET (optional)
- INTEGRATOR (totalizer) AND PEAK/VALLEY (max/min) MEMORY (optional)
- DUAL ALARM RELAY OUTPUTS (optional)
- BI-DIRECTIONAL SERIAL COMMUNICATIONS (optional)
- 4 to 20 mA OR 0 to 10 VDC RE-TRANSMITTED ANALOG OUTPUT (optional)



- NEMA 4/IP65 SEALED METAL FRONT BEZEL



DESCRIPTION

The Apollo Intelligent Thermocouple Meter (IMT) accepts inputs from standard thermocouples and precisely linearizes them. A full 6-digit display accommodates a wide range of temperature inputs and holds large totalization values. State of the art digital circuitry virtually eliminates errors due to drift. The unit automatically compensates for cold junction, NBS linearity and the meter's zero and span. A full complement of option packages are available to fulfill many process applications.

The indicator features a readout choice of either Fahrenheit or Celsius with 0.1 or 1 degree of resolution. English Style display prompts and front panel buttons aid the operator through set-up and operation. With a few simple steps the unit can be engaged as a millivolt meter by programming "mV" for thermocouple type (enter 8 in "Pro 1"). This mode is useful in monitoring and displaying the actual voltage produced at the thermocouple probe junction as an aid in troubleshooting for a faulty thermocouple probe. A front panel lock-out menu protects set-up data and operation modes from unauthorized modification. Programmable digital filtering enhances the stability of the reading. Programmable remote input "E1-CON" pin can be utilized to control a variety of functions, such as totalizing, alarm control, peak/valley readings, display hold, or temperature offset operations. All set-up data is stored in E²PROM, which will hold data for a minimum of 10 years without power.

An optional integrator/totalizer can be used to totalize or integrate temperatures up to a maximum display value of 999,999. It features independent scaling, decimal point, and a low temperature cut-out to suit a wide variety of temperature integration/totalization applications. Programmable remote input "E2-CON" pin is included with this option and can be utilized to control a variety of functions, such as integrating/totalizing, alarm control, peak/valley readings, display hold or temperature offset operations,

simultaneously with "E1-CON" pin. Peak/valley (max/min) reading memory and programmable temperature offset functions are included with this option and they are easily recalled and controlled by either the front panel or a remote input. All readings are retained at power-down.

Optional dual relays with parallel solid state outputs are fully programmable to operate in a wide variety of modes to suit many control or alarm applications.

Optional 20 mA loop, bidirectional serial communications provides computer and printer interfacing to extend the capabilities of the indicator. More than one unit can be connected in the loop with other RLC products which have serial communications capabilities.

An optional 4 to 20 mA or 0 to 10 VDC re-transmitted analog output can be scaled by the user to interface with a host of recorders, indicators and controllers. The indicator has several built-in diagnostic functions to alert operators of any malfunction. Extensive testing of noise interference mechanisms and full burn-in makes the indicator extremely reliable in industrial environments. The die-cast front bezel meets NEMA 4/IP65 requirements for washdown applications.

SAFETY SUMMARY

All safety related regulations, local codes and instructions that appear in the manual or on equipment must be observed to ensure personal safety and to prevent damage to either the instrument or equipment connected to it. If equipment is used in a manner not specified by the manufacturer, the protection provided by the equipment may be impaired.

Do not use this unit to directly command motors, valves, or other actuators not equipped with safeguards. To do so, can be potentially harmful to persons or equipment in the event of a fault to the unit.

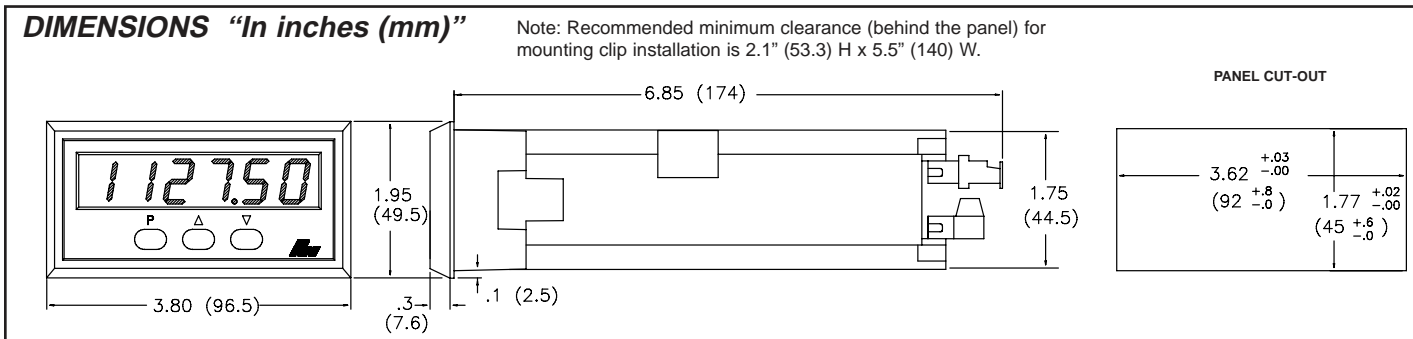

SPECIFICATIONS

- DISPLAY:** 4-digit with F/C indication, 0.56" (14.2 mm) high LED, minus sign displayed for negative temperatures. 6-digits for integrator/totalizer, "Flashing" display for totalizer overflow. "OLOLOL" displayed for input display out of positive range. "ULULUL" displayed for input display out of negative range.
- POWER REQUIREMENTS:**
 - A.C. Power:** Switch Selectable 115/230 VAC, $\pm 10\%$, 50/60 Hz, 14 VA
 - D.C. Power:** 10 to 30 VDC, 9 Watts max., isolated to 300 Vp.
- CONTROLS:** Three front panel push buttons for modifying alarm values and indicator set-up. Two external inputs for disabling the front panel and controlling programmable functions.
- THERMOCOUPLE TYPES:** T, E, J, K, R, S, B, N or mV scale
- RESOLUTION:** 1 degree for all types, or 0.1 degree for T, E, J, K, and N only.
- INPUT IMPEDANCE:** 20 M Ω , all types.
- LEAD RESISTANCE EFFECT:** 20 μ V/350 Ω
 - Max Input Voltage Protection:** 70 VDC continuous.
- OPEN THERMOCOUPLE DETECTION:**
 - Display:** "OPEN"
 - Setpoint Outputs:** Disabled (*de-activated*)
 - Serial Output:** "OPEN" in data field.
 - Analog Output:** 20 mA
- COLD JUNCTION COMPENSATION:** Automatic, 0.02 degree/degree. Disabled for linear mV scale.
- READING RATE:** 2.5 readings/second
- RESPONSE TIME:** 2 seconds to settle for step input (*increases with programmable digital filtering*).
- NORMAL MODE REJECTION:** 45 dB at 50/60 Hz (*may be improved by programmable digital filtering*).
- COMMON MODE REJECTION:** 120 dB, DC to 50/60 Hz
- INTEGRATOR/TOTALIZER:** Front panel button for input/total display select. External integrator/totalizer reset/enable. Programmable time-base, scale factor (0.001-999.999) and low-temp cutout. Response Time = 0.2 sec. max.
- E1-CON & E2-CON:** External remote inputs which allow activation of various functions. (Reset total, peak indicator mode, trigger mode, etc.)
 - $V_{IL} = 0.8 V_{MAX}$; $V_{IH} = 2.0 V_{MIN}$. Response Time = 0.2 sec. max.
- ENVIRONMENTAL CONDITIONS:**
 - Operating Temperature Range:** 0 to 50°C
 - Storage Temperature Range:** -40 to 80°C
 - Operator and Storage Humidity:** 85% max (non-condensing) from 0 to 50°C
 - Span Drift:** 40 ppm/°C
 - Zero Drift:** 1 μ V/°C
 - Altitude:** Up to 2000 meters
- SERIAL COMMUNICATIONS (Optional):**
 - Type:** Bi-directional 20 mA current loop, 20 mA source provided on transmit loop. (*Powers up to 7 units in a loop with internal current source.*)
 - Baud Rate:** programmable 300 to 2400
 - Maximum address:** 99 (*Actual number in a single loop is limited by serial hardware specifications.*)
 - Data Format:** 10 bit frame, Odd parity (*one start bit, 7 data bit, one odd parity bit, and one stop bit.*)
 - Serial Hardware Specifications:**
 - SO - Output Transistor Rating:** $V_{MAX} = 30$ VDC, $V_{SAT} = 1 V_{MAX}$ at 20 mA.
 - Note: This will allow up to 28 units max. in each loop.*
 - SI - Input Diode Rating:** $V_F = 1.25 V_{TYP}$; $1.5 V_{MAX}$
 - Note: The compliance voltage rating of the source must be greater than the sum of the voltage drops around the loop. (Typically, a 30 VDC powered source would be capable of operating between 18 and 22 units in a loop.)*
- ALARMS (Optional):**
 - Solid State:** Two, isolated sinking open collector NPN transistors acting in parallel with relays. $V_{SAT} = 1$ V @ 100 mA max. V_{max} : 30 VDC.
 - Relays:**
 - Type:** Form C (2)
 - Rating:** 5 Amps @ 120/240 VAC or 28 VDC resistive, 1/8 hp @ 120 VAC (*inductive load*).
 - Relay Life Expectancy:** 100,000 cycles at max. rating. (*As load level decreases, life expectancy increases.*)
- ANALOG OUTPUT (Optional):**
 - 4 to 20 mA:** Digital scaling and offsetting within 4 to 20 mA range.
 - Accuracy:** 0.1% of full scale
 - Resolution:** 12 bits
 - Compliance Voltage:** 10 VDC (*500 Ω max. loop impedance*)
 - 0 to 10 VDC:** Digital scaling and offsetting within 0 to 10 VDC range.
 - Accuracy:** $\pm 0.1\%$ of reading +35 mV
 - Resolution:** 12 bits
 - Min. Load Resistance:** 10 K Ω (*1 mA max.*)

20. PEAK/VALLEY/SLOPE/OFFSET (Optional):

Peak and Valley recording. Programmable temperature offset and slope.

21. CERTIFICATIONS AND COMPLIANCES:

EMC EMISSIONS:

Meets EN 50081-2: Industrial Environment.
CISPR 11 Radiated and conducted emissions

EMC IMMUNITY:

Meets EN 50082-2: Industrial Environment.
ENV 50140 - Radio-frequency radiated electromagnetic field¹
ENV 50141 - Radio-frequency conducted electromagnetic field
EN 61000-4-2 - Electrostatic discharge (ESD)²
EN 61000-4-4 - Electrical fast transient/burst (EFT)

Notes:

- Unit complies with listed specifications at 10 V/m, with unit installed in a metal panel, rear of the unit covered with a metal enclosure providing at least 5 dB of shielding effectiveness and mounted to an aluminum rack connected to earth ground (protective earth). All I/O cables routed through metal conduit that is connected to earth ground at both ends.*
 - Unit complies with listed specifications at 6 V/m, with unit installed in a metal panel mounted to an open aluminum rack connected to earth ground.*
 - At 10 V/m, with unit installed in a metal panel mounted to the open aluminum rack, the process signal and 4 to 20 mA analog output option can vary out of range from specifications.*
 - Metal bezel of unit connected with ground lead from rear bezel screw to metal mounting panel.*
- Refer to the EMC Compliance Installation section of the manual for additional information.
- CONSTRUCTION:** Die-cast metal front bezel that meets NEMA 4/IP65 requirements for indoor use when properly installed. Installation Category II, Pollution Degree 2. Case body is black high impact plastic (panel gasket and mounting clips included).
 - CONNECTION:** Fixed and removeable terminal blocks.
 - WEIGHT:** 1.2 lbs (0.54 kg).

THERMOCOUPLE RANGE AND ACCURACY TABLE

All errors include NBS conformity, cold junction effect and A/D conversion errors at 23° C after 10 minutes warm-up. Relative Humidity less than 85% R.H.

| TC TYPE/ PRO 1 CODE | RANGE | ACCURACY | WIRE COLOR |
|------------------------|------------------------------------|----------------|---------------|
| T/0 | -200 to +400°C 328 to +752°F | 0.8°C 1.4°F | blue |
| E/1 | -200 to +1000°C -328 to +1832°F | 0.8°C 1.4°F | purple |
| J/2 | -200 to +760°C -328 to +1400°F | 0.8°C 1.4°F | white |
| K/3 | -200 to +1250°C -328 to +2282°F | 0.8°C 1.4°F | yellow |
| R/4 | 0 to +1768°C +32 to +3214°F | 2.1°C 3.8°F | black |
| S/5 | 0 to +1768°C +32 to +3214°F | 2.1°C 3.8°F | black |
| B/6 | +150 to +1820°C +302 to +3308°F | 2.3°C 4.1°F | grey |
| N/7 | -200 to +1300°C -328 to +2372°F | 0.8°C 1.4°F | orange |
| mV/8 | -10.00 to +90.00 mV | 0.01% | - |

INTEGRATOR (TOTALIZER) / PEAK/VALLEY / TEMPERATURE OFFSET AND SLOPE OPTION

The major feature of this option is its integrator/totalizer (*accumulator*). The integrator/totalizer simply totals (*adds*) input readings with a programmable time base and scaling coefficient. The integrator/totalizer may be reset via a remote input, by the front panel or through the serial communications loop. Alarms may be programmed to trigger from integrator/totalizer values or input values. A programmable low temperature/signal level disable feature completes the integrator/totalizer features. At loss of power to the indicator, the contents of the integrator are saved.

Another feature of this option is peak and valley detection. The indicator will record the lowest reading (*valley*) and the highest reading (*peak*), automatically, for later recall. This information is valuable to monitor the limits of the process over any length of time (*shifts, days, etc*) since these values are stored at power-down. A remote input can be programmed to reset or engage the unit into a peak reading indicator/totalizer. Additionally, the peak and valley can be viewed and reset from the front panel, if so programmed, and viewed and reset through the serial communication option.

The programmable temperature offset feature allows the operator to shift the displayed temperature reading. The operator may utilize this feature, for example, if switching thermocouple probes, to compensate for differences in thermocouple probe accuracy from one manufacturer to another. The displayed temperature reading can be offset either positive or negative to the actual measured temperature. Programming a positive number for the offset value

increases the display value. Programming a negative number for the offset value decreases the display value. For example, programming +10 for the offset value will increase the displayed value by 10 throughout the entire range, or programming -10 for the offset value will decrease the display value by 10 throughout the entire range.

ISOLATED ALARM OPTION

The alarm option consists of an additional printed circuit board with 9 connections. Six of these terminals are for the two Form-C relays and the other three are for the two open collector transistors, which act in parallel with the relays. The two alarms are completely independent with programmable values, hysteresis (*deadband*), high or low acting, auto or manual reset, triggering from input or total and they can be programmed to track each other, if desirable. If the alarms are programmed to latch (*manual reset*), then they can be reset either by the front panel or a remote input. The alarms can be programmed to trigger from either the integrator/totalizer or the input display, to actuate external alarms, control valves, etc.

Alarm #1 can be programmed to track Alarm #2 by enabling alarm tracking. This is useful in alarm set-ups where a pre-warning control activates before a second alarm shuts off the process when tracking is programmed. Changing the shut-off trip value (*alarm #2*) automatically changes the pre-warn value (*alarm #1*) an equal amount. Alarm and hysteresis values can be modified through the optional serial communications to provide automatic control.

ISOLATED SERIAL COMMUNICATIONS OPTION

The serial communication option is a half-duplex, two-way 20 mA loop that can connect to a variety of printers, computers, terminals and controllers to suit

many data-polling or automatic operation applications. The indicator responds to a host of commands, including change alarm value, reset totalizer and transmit input signal. Two loops are required for all hook-ups; a transmit (*out-going data*) loop and a receive (*in-coming data*) loop. Since the indicator monitors the receive loop for a busy signal (*current interrupted*) while transmitting, the receive loop must be connected even if the indicator is transmitting only, such as to a printer. A built-in 20 mA source is provided in the transmit loop. Additionally, multiple units and other Red Lion Controls instruments can be serially addressed, with a maximum address capability of 99 units. (*Note: There are hardware limitations which restrict this to a lower number of units per serial loop.*)

ISOLATED RE-TRANSMITTED ANALOG OUTPUT OPTION

4 to 20 mA

The re-transmitted analog output option transmits a digitally programmable 4 to 20 mA current to drive chart recorders, remote indicators and controllers. The compliance is 10 V. Non-standard current ranges within the 4 to 20 mA range can be supported by calculating the slope and intercept of the display/output and calculating the required display values at 4 and 20 mA.

0 to 10 VDC

The re-transmitted analog output option transmits a digitally programmable 0 to 10 VDC output signal to drive chart recorders, remote indicators and controllers. Non-standard voltage ranges within the 0 to 10 VDC range can be supported by calculating the slope and intercept of the display/output and calculating the required display values to 0 and 10 VDC.

PROGRAMMABLE FUNCTIONS

Programming of the IMT is divided into modular steps. Each module is a short sequence of data entries. The front panel buttons "UP" and "DOWN" are used to change the data and set-ups, while the "P" button is used to 'save' or 'enter' the data. After pressing "P" which gains entry into the programming mode, the programming modules are identified by the message "Pro" and a number in the display. "UP" and "DOWN" are used to select the desired programming module and "P" is used to enter it. All of the subsequent programming steps follow the same procedure. The rear terminal labeled "PGM. DIS." must be ungrounded to gain access to programming. The following table lists the programming steps.

"Pro 0" - RETURN TO MEASUREMENT MODE

"Pro 1" - PROGRAM THERMOCOUPLE TYPE, SCALE AND RESOLUTION

- "tYPE" - Enter thermocouple type
(T=0; E=1; J=2; K=3; R=4; S=5; B=6; N=7; mV=8)
- "SCALE" - Enter temperature scale (F or C)
- "dECPNt" - Enter resolution (0 or 0.0)

"Pro 2" - PROGRAM TEMPERATURE DISPLAY SLOPE AND OFFSET

- "SLOPE" - Enter display slope (0.0001 to 9.9999)
- "OFFSEt" - Enter offset (-999 to 9999)

"Pro 3" - PROGRAM FUNCTIONS ACCESSIBLE WITH FRONT PANEL LOCKOUT ENGAGED

- "dSP AL" - Enable display alarms
- "ENt AL" - Enable enter alarms †
- "dSPHYS" - Enable display hysteresis
- "ENtHYS" - Enable enter hysteresis †
- "rSt AL" - Enable reset latched alarms
- "dSPbUF" - Enable display of peak/valley readings
- "rStbUF" - Enable reset of peak/valley readings †
- "SELdSP" - Enable switching display between input and total
- "rSttOt" - Enable reset total
- "dSPOFF" - Enable display offset
- "ENtOFFt" - Enable enter offset †

"Pro 4" - PROGRAM DIGITAL FILTERING AND REMOTE INPUT FUNCTION

- "FILtEr" - Enter level of digital filtering
 - 0 - no digital filtering
 - 1 - normal filtering
 - 2 - increased filtering
 - 3 - maximum filtering
- "E1-CON" - Enter function of remote input
 - 0 - offset temperature reading to zero
 - 1 - reset totalizer
 - 2 - reset and gate totalizer
 - 3 - gate totalizer
 - 4 - display hold
 - 5 - reset peak/valley
 - 6 - reset peak/peak indicator
 - 7 - reset valley/valley indicator
 - 8 - reset latched alarms

- 9 - reset all alarms
- 10 - toggle display between input and totalizer
- 11 - offset input to zero and totalize the offset values
- 12 - display hold with offset
- 13 - instrument reading synchronization
- 14 - print request
- "E2-CON" - Same functions as E1-CON

"Pro 5" - PROGRAM TOTALIZER

- "dECPNt" - Enter decimal point for totalizer
- "tbASE" - Enter time base
 - 0 - second
 - 1 - minute
 - 2 - hour
- "SCLFAC" - Enter multiplying scale factor
- "Lo-cut" - Enter low-signal cut out

"Pro 6" - PROGRAM ALARMS

- "trAc" - Enable alarm value tracking
- "dISp" - Enable display alarm annunciators
- "LAtC-1" - Enable alarm #1 latching
- "ASN-1" - Enter alarm #1 trigger source (*input or total*)
- "AL-1" - Enter alarm #1 value
- "HYS-1" - Enter hysteresis value for alarm #1
- "Act-1" - Enter alarm #1 action (*high or low*)
- "LAtC-2" - Enable alarm #2 latching
- "ASN-2" - Enter alarm #2 trigger source (*input or total*)
- "AL-2" - Enter alarm #2 value
- "HYS-2" - Enter hysteresis value for alarm #2
- "Act-2" - Enter alarm #2 action (*high or low*)

"Pro 7" - PROGRAM SERIAL COMMUNICATIONS

- "bAud" - Enter baud rate
- "AddrES" - Enter loop address number (0-99)
- "Print" - Enter print function, or "P" command function through Serial Option
 - 0 - temp.
 - 1 - temp., peak/valley and offset
 - 2 - temp. and alarms
 - 3 - temp., peak/valley, alarm, hysteresis and offset
 - 4 - integrator/totalizer
 - 5 - temp. and integrator/totalizer
 - 6 - temp., integrator/totalizer, peak/valley and offset
 - 7 - integrator/totalizer and alarms
 - 8 - temp., integrator/totalizer and alarms
 - 9 - temp., integrator/totalizer, peak/valley, alarms, hysteresis and offset
- "FULL" - Enable complete or abbreviated printing

"Pro 8" - PROGRAM RE-TRANSMITTED ANALOG OUTPUT

- "ASIN" - Select source of analog output (*input or total*)
- "AN-Lo" - Enter 4 mA or 0 VDC display value
- "AN-HI" - Enter 20 mA or 10 VDC display value

"Pro 9" - SERVICE OPERATIONS (Protected by access code)

† - This sequence may be subject to being locked-out due to other programmed sequences.

TEMPERATURE MONITOR/LIMIT CONTROLLER EXAMPLE

Several IMT's are used as temperature indicator/limit controllers for motor bearings at a manufacturing plant. The bearings must be kept lubricated to prevent heat and friction, maximizing the life of the bearings. The normal operating temperature of the bearings depends upon the size of the motor, motor speed, load, etc. Normally, the temperature of the bearings will rise from approximately room temperature at start-up and then level off. A sudden increase in the temperature would signal that the bearing has begun to reach the end of its life.

The IMT's are selected with integrator/totalizer/peak/valley/ temperature offset/slope/E2-CON and dual alarm/relay options. By utilizing the integrator/totalizer option, the bearing temperatures can be integrated (*added*) on a per-hour basis ("*degree-hours*"). When the integrator/totalizer reaches a preset value (*i.e.* 64,000), alarm #1 relay activates a warning signal to alert personnel that maintenance (*lubrication, etc.*) is due. After maintenance, the contents of the integrator/totalizer is reset to 0 and integration/totalization for the next period begins. The low temperature cut-out is programmed to disable integration/totalization at start-up temperatures (90°F) or when the motor is not running. Alarm #2 is set to latch and is used to shut down the motor and alert operators in the event of a sudden increase in the temperature of the bearings (160°F). Daily high (*peak*) temperatures can be viewed by displaying the contents of the peak buffer.

Programming of the IMT is as follows:

| | | |
|---------------------|----------|--|
| "Pro 1"... "TYPE" | - 0 | Type "T" |
| "SCALE" | - F | Degrees Fahrenheit |
| "dECPNT" | - 0 | 1 degree resolution |
| "Pro 2"... "SLOPE" | - 1.0000 | No offset |
| "OFFSE" | - 0 | No offset |
| "Pro 3"... "dSP AL" | - YES | Check alarms |
| "ENT AI" | - NO | No modify alarms |
| "dSPHYS" | - NO | No display hysteresis |
| "rSt AL" | - YES | Manual reset |
| "dSPbUF" | - YES | Display peak/valley |
| "rStbUF" | - YES | Enable reset peak/valley |
| "SELdSP" | - YES | Allow display mode switching |
| "rSttOr" | - NO | Reset by remote switch only |
| "dSPOFF" | - NO | 0 offset programmed |
| "Pro 4"... "FILtEr" | - 1 | Set digital filter to normal |
| "E1-CON" | - 1 | Reset totalizer from remote input |
| "E2-CON" | - | N/A |
| "Pro 5"... "dECPNt" | - 0 | Display total in "degree hours" |
| "tbASE" | - 2 | Set the integrator time base for "1-hour" |
| "SCLFAC" | - 1.000 | Integrate hour to hour |
| "Lo-cut" | - 90 F | Disable integration under 90°F |
| "Pro 6"... "trAc" | - NO | No alarm tracking |
| "dISP" | - YES | Display announcement of alarm status |
| "LAtC-1" | - NO | Alarm will reset when integrator/totalizer reset |
| "ASN-1" | - totAL | Triggers from integrator/totalizer |
| "AL-1" | - 64,000 | Alarm #1 Trigger value |
| "HYS-1" | - 1 | Deadband range (not critical) |
| "Act-1" | - HI | Triggers when above 64,000 (Integrator) |
| "LAtC-2" | - YES | Latch over-temperature alarm |
| "ASN-2" | - InPut | Triggers from temperature (Input) |
| "AL-2" | - 160 | Alarm #2 trigger value |
| "HYS-2" | - N/A | |
| "Act-2" | - HI | Triggers when above 160°F |

HEAT TREATING EXAMPLE

An IMT is employed to monitor the temperature of an oven during a bolt heat treating process. The IMT is chosen with serial, alarm and integrator/totalizer/peak/valley/temperature offset/slope/ E2-CON options, to replace two outdated instruments, an analog temperature indicator and a timer. After the bolts are cut and threaded, they must be hardened by slowly heating to 870°C. When the bolts reach 870°C, they must remain at or slightly above this temperature for 10 minutes. After 10 minutes at 870°C the bolts are removed from the heat to be cooled. The heat treating oven is then brought back down to the start temperature (*approx.* 120°C).

An existing controller is used to slowly heat the bolts to 870 degrees. The IMT monitors and displays this temperature. The integrator/totalizer option of the IMT is used to replace the timer. When the temperature reaches 870°, integration/totalization begins (*Lo-cut = 870 C*). With the temperature at a steady 870°, after 10 minutes the contents of the integrator/totalizer will equal 145. At this time alarm #1 activates a control system which removes the bolts from the heat and takes them to be cooled down. The integrator/totalizer is reset to 0, and the heat treating oven is brought back down to starting temperature. Alarm #2 is programmed to be low acting (*temp below 120°*) and is used to signal operators that the process is ready to begin again. The serial communication option is selected to link up to an industrial computer, which enables remote programming of the IMT.

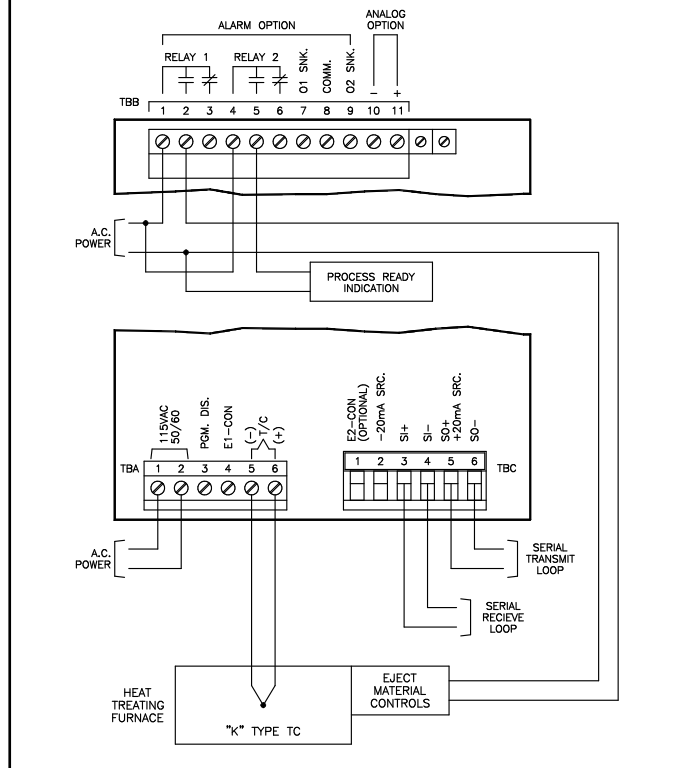

ORDERING INFORMATION

| MODEL NO. | DESCRIPTION | TOTALIZER/INTEGRATOR PEAK/VALLEY/SLOPE OFFSET/E2-CON | DUAL ALARM | SERIAL OUTPUT | ANALOG OUTPUT | PART NUMBERS FOR AVAILABLE SUPPLY VOLTAGES | |
|-----------|---|--|-------------|---------------|---------------|--|-------------|
| | | | | | | *10-30 VDC | 115/230 VAC |
| IMT | Intelligent Meter For Thermocouple Inputs | NO | NO | NO | NO | IMT00030 | IMT00060 |
| | | NO | YES | NO | NO | IMT00032 | IMT00062 |
| | | YES | NO | NO | NO | IMT02030 | IMT02060 |
| | | YES | NO | YES | NO | IMT02031 | IMT02061 |
| | | YES | YES | NO | NO | IMT02032 | IMT02062 |
| | | YES | NO | NO | 4 to 20 mA | IMT02033 | IMT02063 |
| | | YES | YES | YES | 4 to 20 mA | IMT02037 | IMT02067 |
| YES | YES | YES | 0 to 10 VDC | IMT02039 | IMT02069 | | |

For more information on pricing, Enclosures & Panel Mount Kits refer to the RLC Catalog or contact your local RLC distributor.

* Note: The 10 to 30 VDC versions of the IMT have not been specified for EMC.