

6P10S LED Driver with PWM-Control Mixed-Mode Dimming

Features

- Input voltage range: 2.7V to 5.5V
- Drive up to 60 LEDs (10S6P)
- High efficiency LED driver, up to 90%
- High frequency step-up converter (1000kHz)
- Integrated 40V power MOSFET
- Integrated 6-channel current sinks
 - Up to 30mA/ch
 - 0.5% Typ. current matching
 - 2% Typ. current accuracy at 20mA
- Wide input PWM dimming frequency range
 - 300Hz to 30KHz
- Programmable Mixed-Mode Dimming controls
 - Mixed analog dimming and PWM dimming
 - Selectable transition point : 25% or 12.5% input PWM duty cycle
 - Selectable output PWM dimming frequency : fixed 62.5kHz or following input PWM dimming frequency
 - Channel current phase shift in fixed 62.5kHz output PWM dimming mode
- Input PWM glitch filter
- LED open/short protection
- Adjustable over-voltage protection
- Cycle-by-cycle inductor current limit (2.5A)
- 0.1 μ A shutdown current
- TQFN33-16 and WLCSP-16 Package
- RoHS and Green Compliant
- -40°C to +85°C Temperature Range

Applications

- Tablet Backlight
- Netbook/Notebook Backlight
- Portable media players

Brief Description

KTD3156B is the ideal power solution for LED backlighting in medium to large size LCD panels. It is a highly integrated step-up DC-DC converter with input voltage from 2.7V to 5.5V, accommodating 1-cell lithium ion batteries or 5V supply. KTD3156B integrates a 40V power MOSFET as well as six current sinks, which results in a simpler and smaller solution with fewer external components. High switching frequency allows the use of a smaller inductor and capacitor to further reduce the solution size.

Each of the six current sinks regulates up to 30mA. With a 40V rated output, each string of the boost can connect up to 10 LEDs in series, for a total of 60 LEDs.

KTD3156B features mixed-mode dimming, which switches between PWM dimming at low dimming duty cycle and analog (DC current) dimming at high dimming duty cycle to increase the total power efficiency. The transition point of these two modes is programmable to 12.5% or 25% PWM duty cycle. The PWM dimming mode's output PWM dimming frequency can be programmed to fixed 62.5kHz or following input PWM dimming frequency. For fixed 62.5kHz output PWM dimming, phase shift function is implemented among these six channels to further lower the input current ripple and output voltage ripple.

Various protection features are built into KTD3156B, including cycle-by-cycle input current limit protection, output over-voltage protection, LED fault (open or short) protection and thermal shutdown protection. The leakage current in shutdown mode is 0.1 μ A.

KTD3156B is available in a RoHS and Green compliant 16-lead 3 x 3 x 0.75mm ThinQFN or 16-lead 1.65mm x 1.65mm WLCSP package.

Typical Application

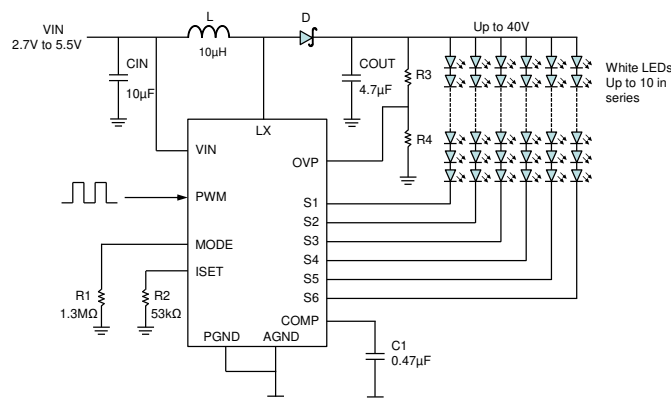

Pin Descriptions

TQFN33-16	WLCSP-16		
Pin #	Pin #	Name	Function
1	1A	PWM	Pulse width controlled dimming input. An active high logic level enables the device. An internal pull down disables the part if PWM pin is left unconnected.
2		NC	Not internally connected.
3	2A	ISET	LED current setting pin. Connect a resistor from this pin to GND to program the maximum LED current.
4	3A	COMP	Boost converter loop compensation pin. Connect a 0.47uF ceramic capacitor to GND.
5	4A	S6	Regulated output current sink #6
6	3B	S5	Regulated output current sink #5
7	4B	S4	Regulated output current sink #4
8	3C	GND	Analog ground
9	4D	S3	Regulated output current sink #3
10	4C	S2	Regulated output current sink #2
11	3D	S1	Regulated output current sink #1
12	2D	OVP	Over voltage protection sense pin. Connect to external resistor divider.
13	1D	PGND	Power ground
14	1C, 2C	LX	Switching node of the step-up converter
15	1B	VIN	Input supply pin for the device
16	2B	MODE	Connect an external resistor to GND to program the dimming mode. Refer to MODE resistor selection table.
MC		MC	Metal chassis. Connect to ground for electrical and thermal usage. MC is internally connected to Analog Ground pin.

TQFN33-16
(Top View)

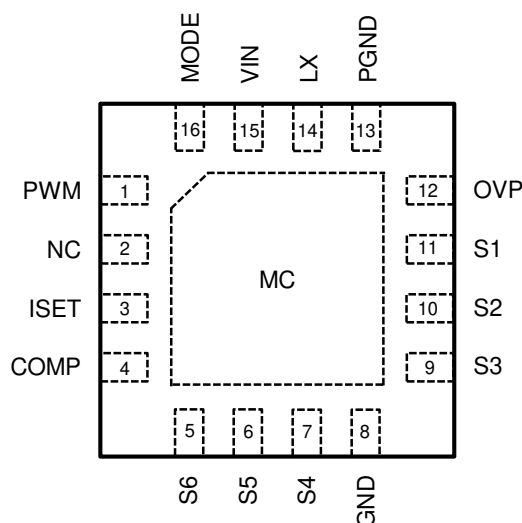

WLCSP-16
(Top View)

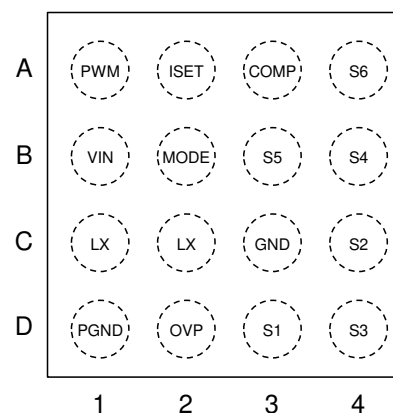

Absolute Maximum Ratings¹

(T_A = 25°C unless otherwise noted)

Symbol	Description	Value	Units
V _{IN}	Input voltage	-0.3 to 6	V
L _X	LX pin voltage	-0.3 to 44	V
S _x	Sx sink pin voltage	-0.3 to 22	V
PWM, ISET, COMP, OVP, MODE	Low voltage pin	-0.3 to V _{IN} +0.3	V
T _J	Operating Temperature Range	-40 to 150	°C
T _s	Storage Temperature Range	-65 to 150	°C
T _{LEAD}	Maximum Soldering Temperature (at pins, 10 sec)	300	°C
ESD	HBM electrical static discharge	2.0	kV

1. Stresses above those listed in Absolute Maximum Ratings may cause permanent damage to the device. Functional operation at conditions other than the operating conditions specified is not implied. Only one Absolute Maximum rating should be applied at any one time.

Thermal Capabilities

Symbol	Description	Value	Units
TQFN33-16			
θ _{JA}	Thermal Resistance – Junction to Ambient ²	43	°C/W
P _D	Maximum Power Dissipation at T _A ≤ 25°C	2.0	W
ΔP _D /ΔT	Derating Factor Above T _A = 25°C	-20	mW/°C

2. Junction to Ambient thermal resistance is highly dependent on PCB layout. Values are based on thermal properties of the device when soldered to an EV board.

Ordering Information

Part Number	Marking ³	Operating Temperature	Package
KTD3156BEFJ-TR	HYYYZ	-40°C to +85°C	TQFN33-16
KTD3156BEUJ-TR	HYYYZ	-40°C to +85°C	WLCSP-16 1.65mm x 1.65mm

3. "YYZ" is the date code and assembly code.

Electrical Characteristics⁴

Unless otherwise noted, the *Min* and *Max* specs are applied over the full operation temperature range of -40°C to +85°C, while *Typ* values are specified at room temperature (25°C). $V_{IN} = 3.6V$.

Symbol	Description	Conditions	Min	Typ	Max	Units
IC Supply						
V_{IN}	Input operating range		2.7		5.5	V
UVLO	Input under voltage lockout	Rising edge		2.5	2.65	V
UVLO _{HYST}	UVLO hysteresis			0.15		V
I_Q	IC standby current	Not switching		2.5		mA
	IC operating current	Switching		3.6		mA
I_{SHDN}	Shutdown current	$V_{IN} = 5.5V$			1	μA
Step-Up Converter						
$R_{DS(ON)}$	NMOS on-resistance			0.26		Ω
I_{LIM}	Peak NMOS current limit			2.5		A
F_{SW}	Oscillator frequency			1000		kHz
D_{max}	Maximum duty cycle			93		%
V_{OVP}	Output over voltage OVP pin threshold			1.50		V
V_{OVP_SC}	Output short to GND OVP pin threshold			100		mV
Current Sink						
I_D	Output current accuracy	Current setting = 20mA ($R_{ISET}=53k$, $T_A = 25^\circ C$)		±2		%
	Output current matching ⁵	Current setting = 20mA ($R_{ISET}=53k$, $T_A = 25^\circ C$)		0.5		%
V_{SOV}	Current sink over-voltage threshold			8.5		V
T_{FAULT}	Current sink fault delay	Analog dimming		65		ms
F_{DIM}	Output PWM dimming frequency	Mode 1, 3		62.5		kHz
Logic Control ; PWM/EN						
V_{TH-L}	PWM pin logic low threshold				0.4	V
V_{TH-H}	PWM pin logic high threshold		1.4			V
R_{PWM}	PWM pin pull-down resistor			400		kΩ
T_{OFF}	PWM pin minimum shut down pulse width timing		8			ms
F_{PWM}	Input PWM dimming frequency		300		30000	Hz
D_{PWM_MIN}	Input PWM minimum duty cycle	Mode 1 Mode 2 Mode 3 Mode 4		1.2 0.7 0.7 0.7		%
PWM_{RES}	Input PWM sampling resolution	$F_{PWM} < 3.9kHz$ $F_{PWM} < 7.8kHz$ $F_{PWM} < 15.6kHz$ $F_{PWM} < 30kHz$		12 11 10 9		bits
Thermal Shutdown						
T_{J-TH}	IC junction thermal shutdown threshold			150		°C
	IC junction thermal shutdown hysteresis			15		°C

4. KTD3156B is guaranteed to meet performance specifications over the -40°C to +85°C operating temperature range by design, characterization and correlation with statistical process controls.

5. The current matching between channels is defined as $|I_D - I_{avg}|_{max} / I_{avg}$.

Typical Characteristics

$V_{IN} = 3.6V$, $L = 10\mu H$ (Coilcraft LPS4018-103ML), $C_{IN} = 10\mu F$, $C_{OUT} = 4.7\mu F$, $R_{ISET} = 53k\Omega$ with 6P6S LEDs at 20mA, $T_{AMB} = 25^\circ C$ unless otherwise specified.

Efficiency vs. Input Voltage

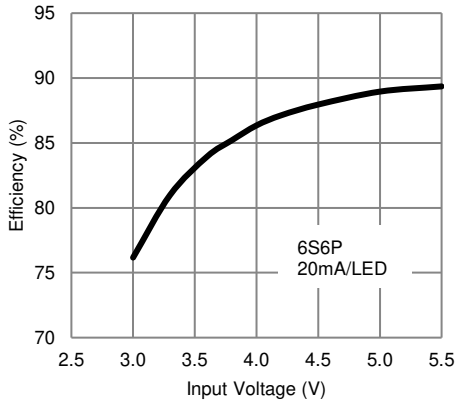

Efficiency vs. PWM Duty Cycle (Mode1)

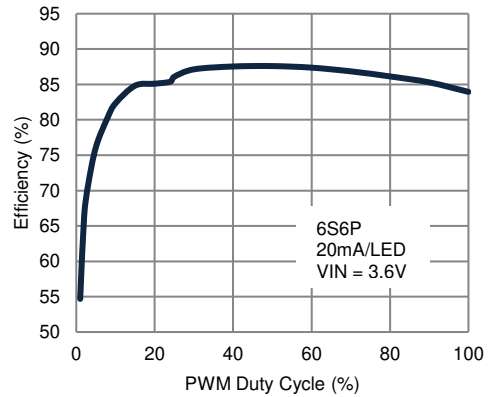

Quiescent Current (non-switching)

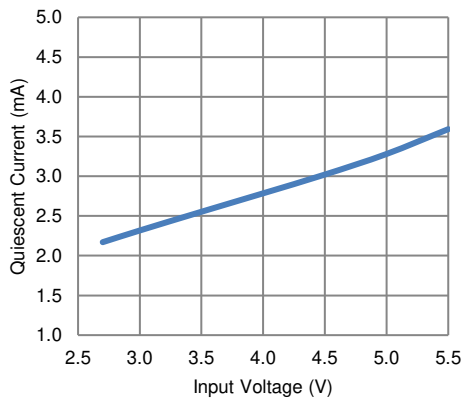

Operating Current (switching)

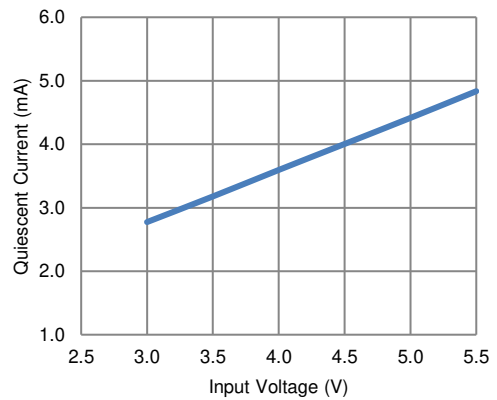

Switching Frequency

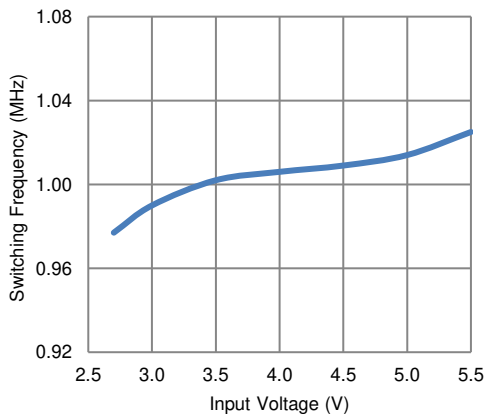

PWM Logic Threshold Voltage

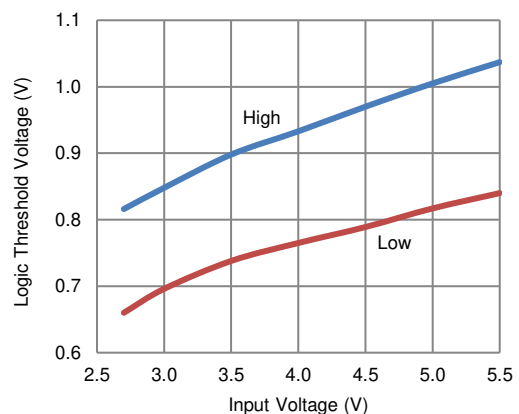

Typical Characteristics (continued)

$V_{IN} = 3.6V$, $L = 10\mu H$, $C_{IN} = 10\mu F$, $C_{OUT} = 4.7\mu F$, $R_{ISET} = 53k\Omega$ with 6P6S LEDs at 20mA, $T_{AMB} = 25^\circ C$ unless otherwise specified.

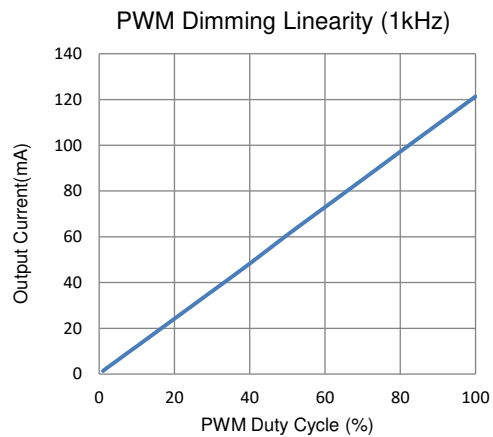
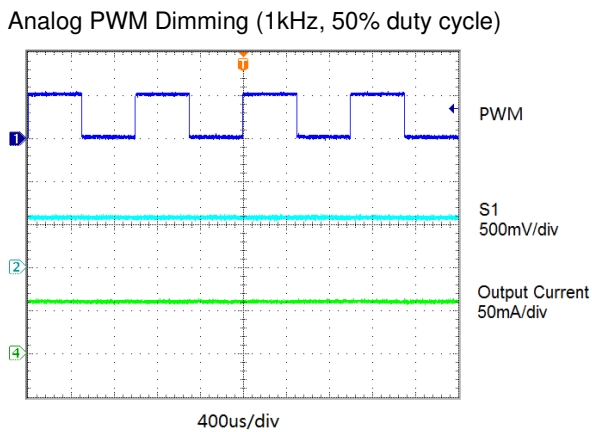
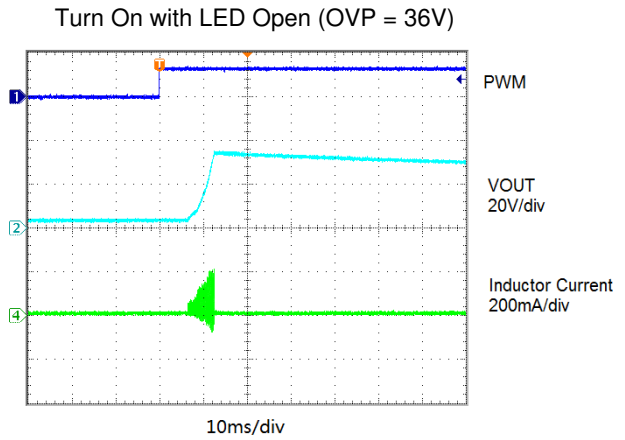
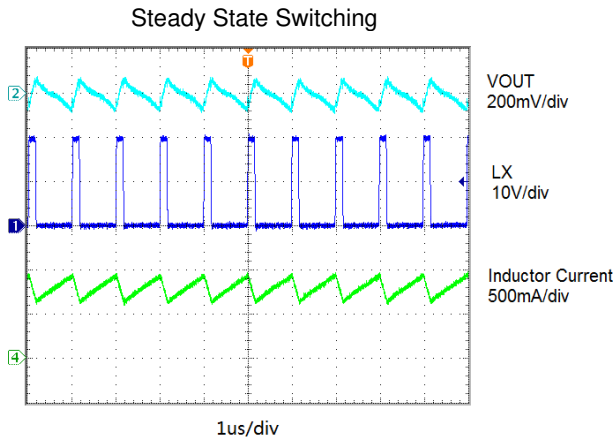
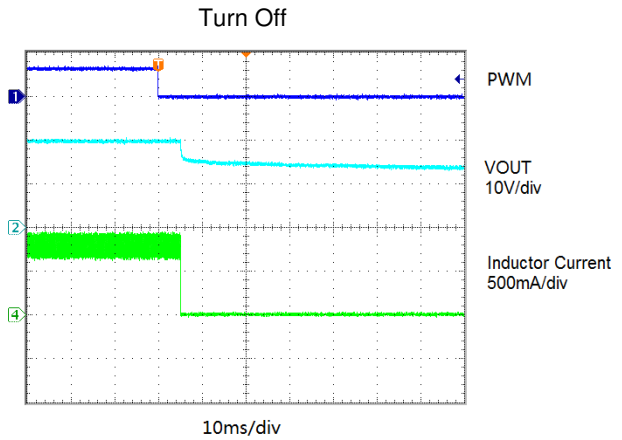
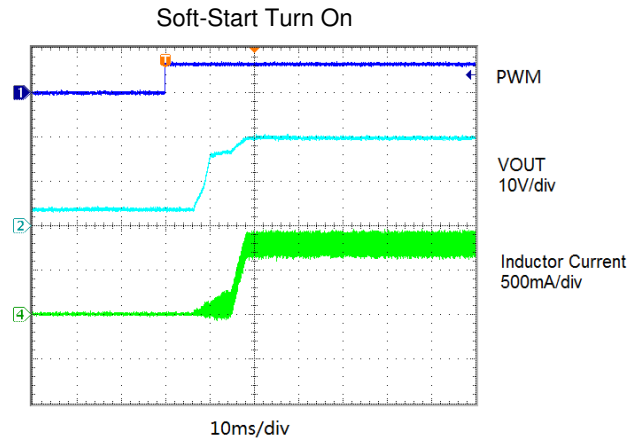

Typical Characteristics (continued)

$V_{IN} = 3.6V$, $L = 10\mu H$, $C_{IN} = 10\mu F$, $C_{OUT} = 4.7\mu F$, $R_{ISET} = 53k\Omega$ with 6P6S LEDs at 20mA, $R_{MODE} = 1.3M\Omega$ (Mode 1) $T_{AMB} = 25^\circ C$ unless otherwise specified.

Digital PWM Dimming (1kHz, 10% duty cycle)

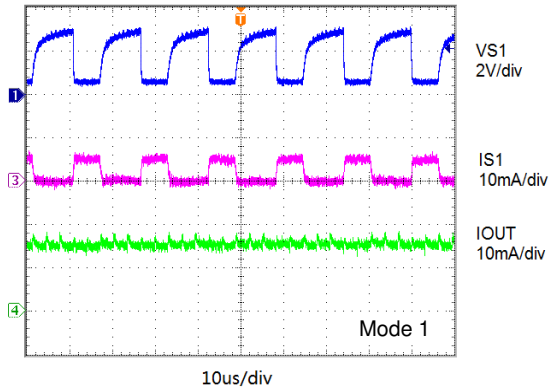

Digital PWM Dimming (1kHz, 20% duty cycle)

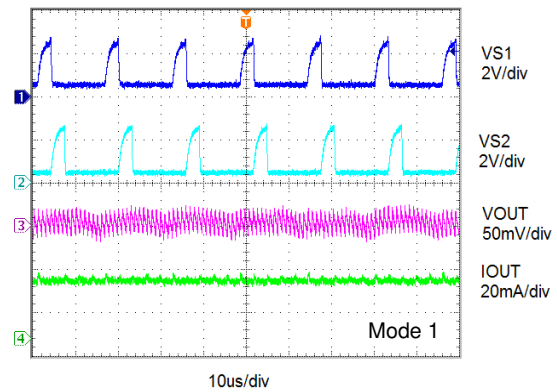

Functional Block Diagram

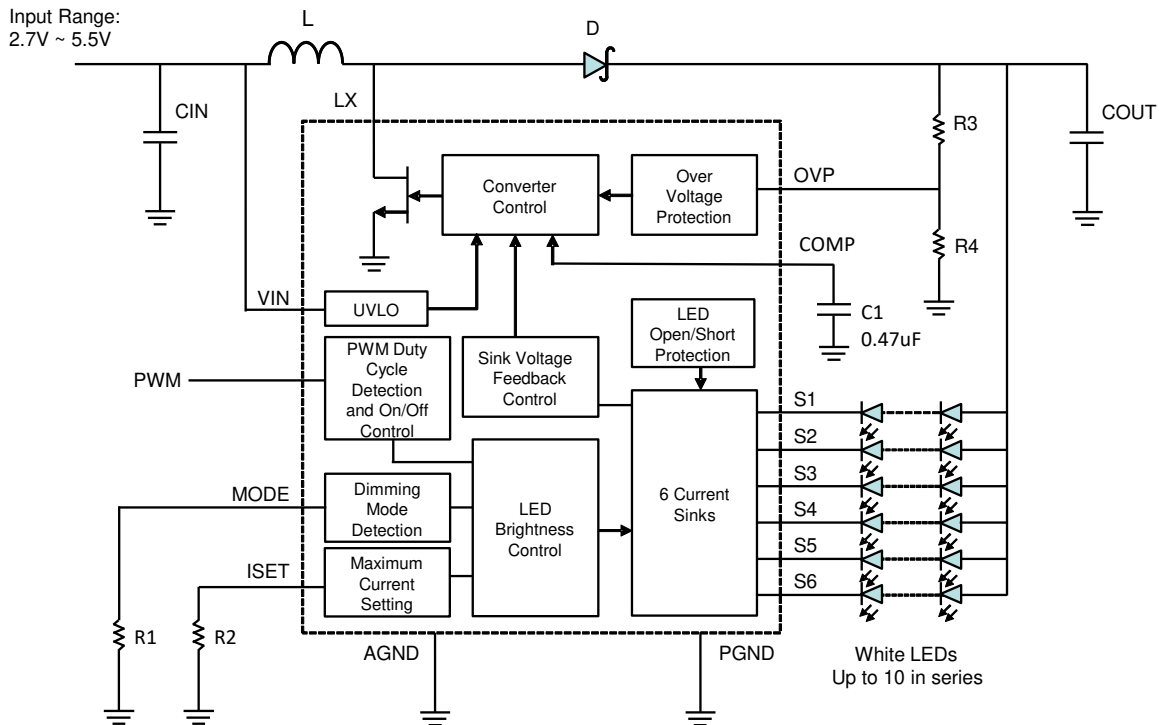

Functional Description

KTD3156B is a unique current regulated step-up (boost) converter. Six current sinks are integrated to drive 6 strings of LEDs with good current matching. Unused channels need to be connected to ground (GND).

The voltage step-up is accomplished by a boost topology, using an inductor-based DC-DC switching converter, in which the inductor serves as an energy storage device in the system. By integrating a high voltage optimized MOSFET, KTD3156B internal switching frequency is 1000kHz while still maintaining high power efficiency. Unlike a traditional DC-DC boost converter with a fixed output voltage, KTD3156B dynamically changes its output voltage depending on the load. The use of unique control schemes maintains accurate current regulation in each of the six current sinks while leaving the output voltage at a minimum, increasing the overall conversion efficiency. The internal step-up converter dynamically controls the voltage at the output high enough to drive the LED string with the highest total forward voltage.

KTD3156B uses the input PWM dimming signal for mixed-mode dimming. When the input PWM signal's dimming duty cycle is high, the IC operates in analog dimming mode, which converts the input PWM signal's duty cycle information into DC value and output the DC current to control LED brightness. When the input PWM signal's dimming duty cycle is low, the IC automatically switches to PWM dimming mode, where the LED current is pulsed on and off to control LED dimming. Mixed-mode dimming offers the advantage of improved LED optical output power efficiency at the high LED brightness condition as well as reduced color shift due to LED forward current change at the low LED brightness condition. The mode transition threshold between analog and PWM dimming can be programmed to either 25% or 12.5% by the external resistor connected at MODE pin.

Application Information

KTD3156B allows maximum flexibility with a PWM signal control input for LED current dimming. The input PWM dimming frequency can be as low as 300Hz and as high as 30kHz.

Maximum LED Current Setting

The maximum current through each of KTD3156B's sinks can be programmed by selecting a resistor connected between ISET and GND, the programmable range is up to 30mA. The following equation sets the maximum current through each of the Sx pins:

$$I_{LED_MAX}[mA] = \frac{1065}{R_{ISET}[k\Omega]}$$

Where I_{LED_MAX} is the maximum LED current per string, and R_{ISET} is the value of the resistor between ISET and GND.

Mixed-mode Dimming Control

KTD3156B uses a PWM input dimming signal for mixed-mode dimming. When the dimming duty cycle is high, the IC operates in analog dimming mode, which uses DC current output to control brightness dimming. With low duty cycle PWM input, the IC automatically switches to PWM dimming mode, where the LED current is pulsed on and off to control LED dimming. The mode transition threshold between analog and PWM dimming can be programmed using an external resistor connected at MODE pin.

KTD3156B provides four dimming mode options as shown in Table 1. There are two mixed-mode transition threshold options: 25% or 12.5%. KTD3156B also offers a choice of 62.5kHz fixed frequency PWM dimming or direct PWM dimming mode (output PWM dimming frequency follows input PWM dimming frequency).

Table 1. Dimming Mode Setting

Mode	MODE Resistor (R1)	Dimming Mode Control	Transition Threshold Between Analog Dimming and PWM Dimming	LED Peak Current during PWM Dimming	LED Current Duty Cycle during PWM Dimming
Mode-1	1.3MΩ (5%)	Analog (DC Current) dimming and 62.5kHz PWM dimming with phase shift	25%	1/4 of maximum LED current	4 times of input PWM duty cycle
Mode-2	620KΩ (5%)	Analog (DC Current) dimming and direct PWM dimming	25%	1/4 of maximum LED current	4 times of input PWM duty cycle
Mode-3	220KΩ (5%)	Analog (DC Current) dimming and 62.5kHz PWM dimming with phase shift	12.5%	1/8 of maximum LED current	8 times of input PWM duty cycle
Mode-4	82KΩ (5%)	Analog (DC Current) dimming and direct PWM dimming	12.5%	1/8 of maximum LED current	8 times of input PWM duty cycle

Analog (DC Current) Dimming Mode

In analog dimming mode, the IC controls the DC LED current to accomplish brightness dimming. This method saves power in the boost converter because the LED forward voltage drops when its DC current reduces, so the required output voltage can become lower when dimming duty cycle decreases.

In analog dimming mode, the current of Sx pin is regulated by following equation;

$$I_{LED} = I_{LED_MAX} \times Duty$$

Where I_{LED} is the LED current per string, I_{LED_MAX} is the maximum LED current set by the resistor between ISET and GND, and Duty is the duty cycle of the PWM input signal.

PWM Dimming Mode

When the PWM input dimming duty cycle is below the transition threshold, KTD3156B automatically enters PWM dimming mode. In this mode, the current sink regulators are turned on and off according to the internally calculated duty cycle information, with average LED current proportional to the duty cycle of the PWM input signal.

During a current sink's ON time in PWM dimming mode, its peak output current is set to the DC current at the transition threshold. For example, if the transition threshold is programmed as 25%, the sink current during the ON time is equal to $I_{LED_MAX}/4$, and its duty cycle is equal to $4 \times \text{Duty}$, where Duty is the input PWM signal's duty cycle information. In this way, the average current during PWM dimming is still calculated as $I_{LED_MAX} \times \text{Duty}$. If the transition threshold is programmed to 12.5%, the sink current during the ON time is equal to $I_{LED_MAX}/8$, and its duty cycle is set to $8 \times \text{Duty}$. Refer to Figure 1 (a) & (b) for a graphical explanation.

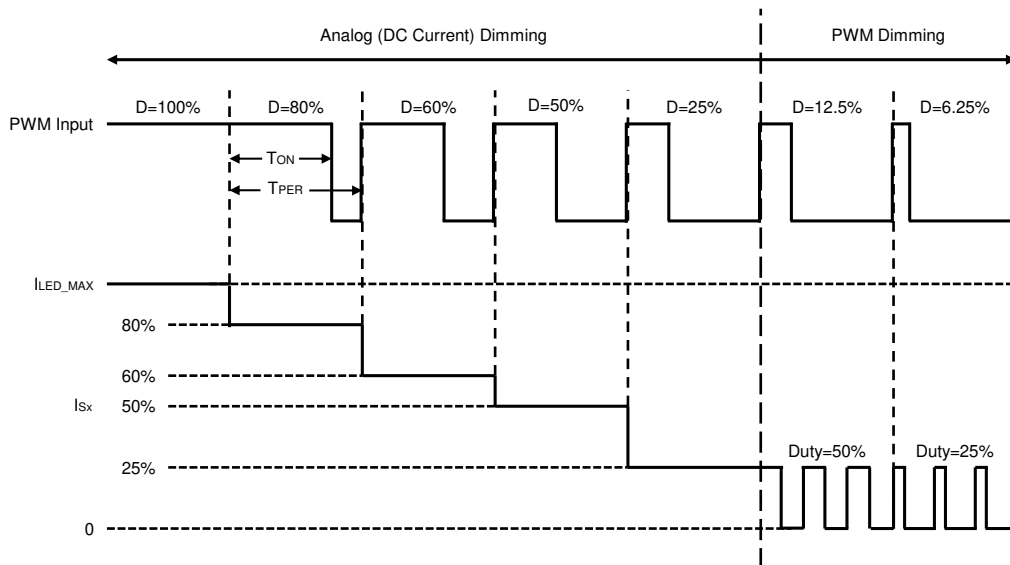

(a) Mixed-mode Dimming in Mode 1, 2 (25% duty cycle threshold)

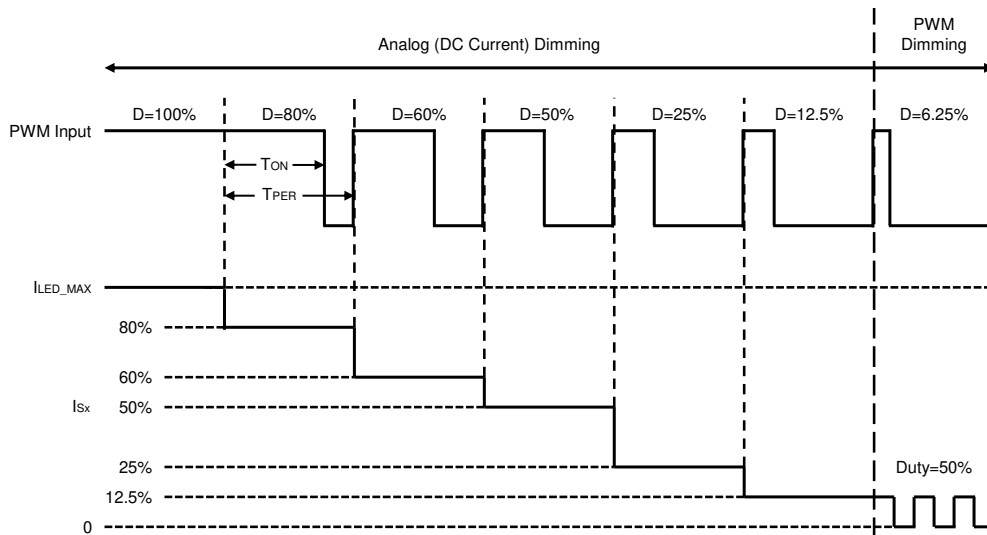

(b) Mixed-mode Dimming in Mode 3, 4 (12.5% duty cycle threshold)

Figure 1. Mixed-mode Dimming Control

KTD3156B's current sinks' on/off frequency in PWM dimming mode is dependent on the mode setting. Either direct PWM dimming mode or 62.5kHz fixed frequency PWM dimming mode can be selected.

In direct PWM dimming mode, the current sinks' PWM frequency equals to the frequency of the PWM input signal. In this way, the dimming frequency can be adjusted to the desired frequency. In order to avoid potential audible noise, a PWM frequency above 20kHz is recommended when using direct PWM dimming mode.

In 62.5kHz fixed frequency PWM dimming mode, the current sinks' PWM frequency is fixed to 62.5kHz frequency. This mode facilitates the application where the input PWM signal frequency can't be adjusted outside the audio frequency range and still can guarantee no audible noise. To further minimize the output voltage ripple and input current ripple in this 62.5kHz fixed frequency PWM dimming mode, phase shift function is implemented among these 6 channels. If any channel is disabled or any channel triggers LED short /open protections, that channel is removed automatically from the phase shift loop and the remaining channels still maintain the phase shift function.

Over Voltage Protection (OVP)

KTD3156B has over-voltage protection sensed at the OVP pin. The output voltage threshold can be programmed with an external resistor divider to allow optimization of Schottky diode rating and output capacitor rating for lower output voltage applications. The equation for the over-voltage threshold is shown below:

$$V_{OUT_OVP} = 1.5V \times \left(1 + \frac{R_3}{R_4} \right)$$

Where V_{OUT_OVP} is the maximum output voltage, 1.5V is the threshold voltage at the OVP pin, R3 is the upper side resistor value between VOUT and OVP pin (1MΩ for a typical value), R4 is the lower side resistor between OVP pin and GND.

Capacitor Selection

Small size X5R or X7R ceramic capacitors with low ESR are recommended for all applications. A 10μF input capacitor and a 4.7μF output capacitor are suggested. A 0.47μF capacitor at COMP pin is recommended for loop compensation. The voltage rating of these capacitors should exceed the maximum possible voltage at the corresponding pins.

Table 2. Recommended Ceramic Capacitor Vendors

Manufacturer	Website
Murata	www.murata.com
AVX	www.avx.com
Taiyo Yuden	www.t-yuden.com

Schottky Diode Selection

Using a schottky diode is recommended because of its low forward voltage drop and fast reverse recovery time. The average current and peak current rating of the schottky diode should exceed the average output current and the peak inductor current. The voltage rating should also exceed the OVP setting.

Table 3. Recommended Schottky Diodes

Schottky Diode Part Number	Forward Voltage (V)	Forward Current (mA)	Reverse Voltage (V)	Manufacturer
PMEG4010EJ	0.54	1000	40	NXP

Inductor Selection

An inductor in the range of 4.7μH to 10μH with low DCR can be selected for the boost converter. To estimate the inductance required for applications, calculate the maximum input average current as the following

$$I_{IN(MAX)} = \frac{V_{OUT} \cdot I_{OUT(MAX)}}{V_{IN} \cdot \eta}$$

where η is the converter efficiency and can be approximated as 90% for the typical case. In order to have smaller current ripple (to improve efficiency and minimize output voltage ripple), larger inductance will be required. If inductor ripple current needs to be less than 40% of the average input current, then

$$\Delta I_L = \frac{V_{IN} \cdot D \cdot T_S}{L} \leq 40\% \cdot \frac{V_{OUT} \cdot I_{OUT(MAX)}}{V_{IN} \cdot \eta}$$

Where duty cycle can be estimated as

$$D = \frac{V_{OUT} - V_{IN}}{V_{OUT}}$$

Then

$$\Delta I_L = \frac{V_{IN} \cdot (V_{OUT} - V_{IN}) \cdot T_S}{L \cdot V_{OUT}} \leq 40\% \cdot \frac{V_{OUT} \cdot I_{OUT(MAX)}}{V_{IN} \cdot \eta}$$

Therefore the inductance can be calculated as

$$L \geq \frac{V_{IN}^2 \cdot (V_{OUT} - V_{IN}) \cdot \eta}{40\% \cdot V_{OUT}^2 \cdot I_{OUT(MAX)} \cdot f_S}$$

where f_s is the switching frequency of the boost converter.

Table 4. Recommended Inductors

Application	Inductor Part Number	Value (μH)	DCR (Ω)	Saturation Current (A)	Dimensions (mm)	Manufacturer
6S6P	LPS4018-103ML	10	0.200 max	1.3	4x4x1.8	Coilcraft

Fault Protection

Each current sink is protected against LED short or open conditions. If LED short circuit condition arises, the current sink continues to regulate until V_{SINK} reaches the over-voltage threshold V_{SOV}. When any sink node voltage goes above V_{SOV} (8.5V) for more than 65ms (typ.), that channel's current sink is turned off, and other channels still work if they don't trigger this fault condition.

For example, if three or more LEDs on a channel are shorted, the corresponding channel sink voltage will increase. If the voltage goes above 8.5V for more than 70ms, the Current Sink Fault Protection will be triggered and only this faulty string will be disabled by shutting off this current sink. All other channels will continue normal operation if they don't have a fault condition.

In case of an LED failing open, the current sink voltage of the failed string will go close to ground and dominate the boost converter control loop. As a result the output voltage will move up to the over-voltage threshold, set by the external resistor divider. Once the over-voltage incident is flagged internally, the faulty channel(s) will be disabled. Then the output voltage of the boost converter will go back to normal level. During the entire process, the other healthy LED strings continue normal operation.

The fault conditions are reset by setting the PWM pin low or by the power-on-reset function (device power-down).

Thermal Shutdown

Thermal shutdown feature is included in the KTD3156B. When the IC's junction temperature (T_J) reaches 150°C, the IC will immediately enter shutdown mode. Once T_J drops 15°C to approximately 135°C, the IC will resume normal operation.

Recommended PCB layout

PCB layout is very important for high frequency switching regulators in order to keep the loop stable and minimize noise. The input capacitor C_{IN} should be placed very close to the IC VIN pin 15 to get the best decoupling. The path between the LX pin to the inductor L1, Schottky diode D1 and output capacitor C_{OUT} should be kept as short as possible to minimize noise and ringing. The C_{OUT} output capacitor ground should be connected to the power ground PGND pin 13 with a short trace. The external components R_ISET, C_COMP, R_MODE, R_OV1 should all be connected to the analog ground GND pin 8, separate from the power ground, as shown in the recommended layout in Figure 2. The analog ground GND and the power ground PGND are joined together at one location on the U1 center pad.

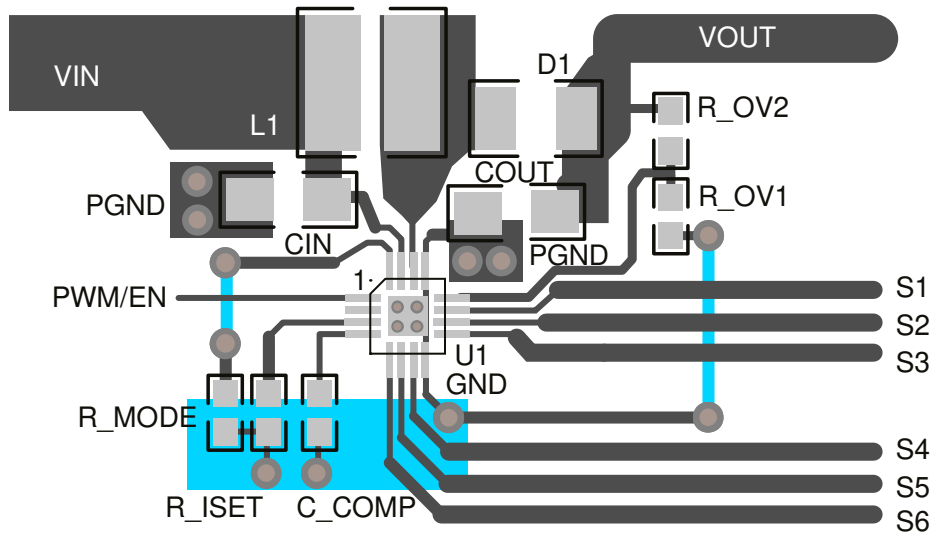

Figure 2. Recommended Layout

Higher Supply Voltage Application

In systems with higher supply voltage above 5V, the inductor can be connected directly to a higher supply voltage V_L up to 20V while the V_{IN} pin is connected to a 5V (or lower voltage) rail, as shown in Figure 3. For normal boost operation, the V_L supply should be lower than any LED string forward voltage by at least 2 V. The capacitor on the inductor supply should have a voltage rating higher than V_L .

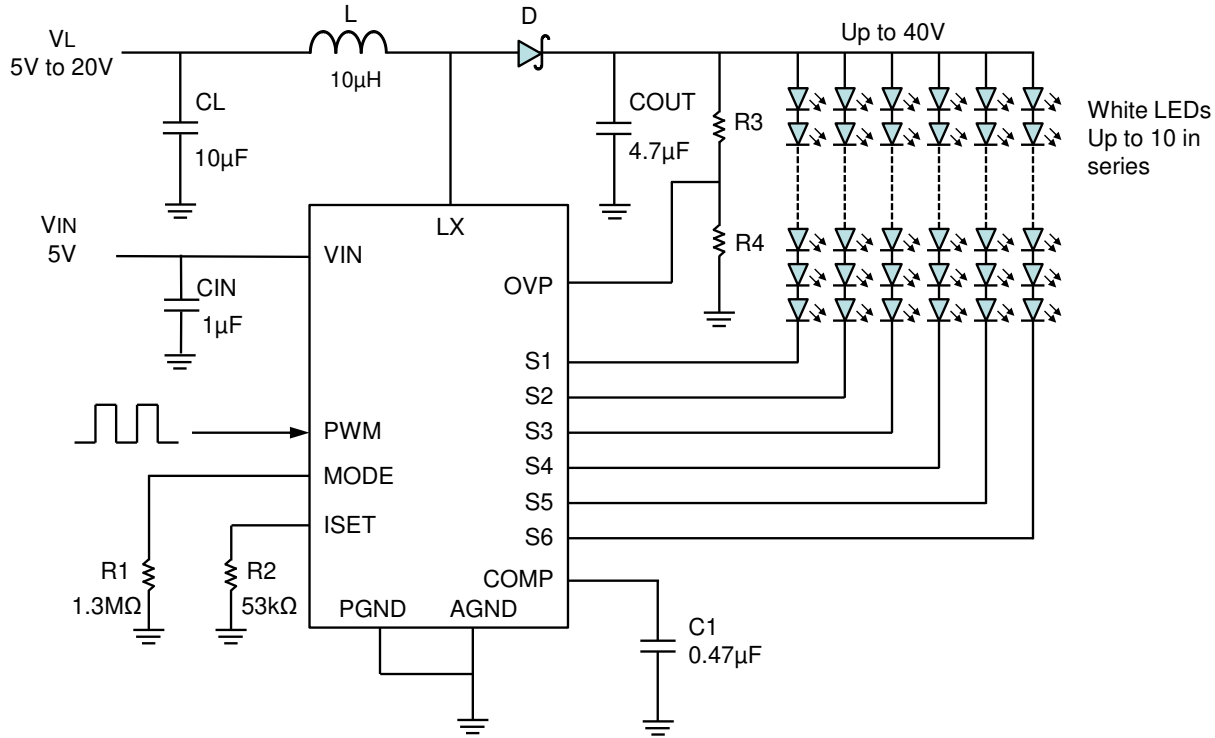
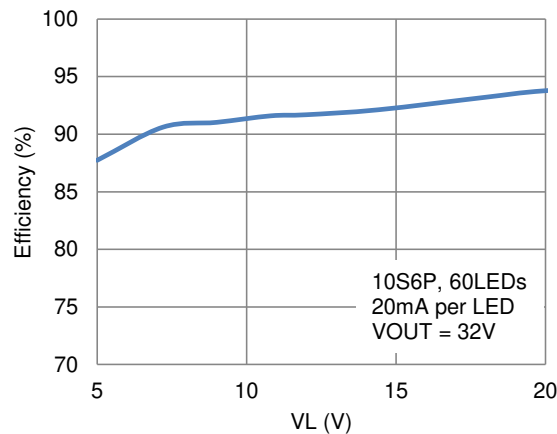

Figure 3. Inductor powered from a higher supply voltage

The following plot shows the efficiency when driving a total of 60 LEDs (10S6P configuration) at 20mA per string or 120mA total output current, with V_L up to 20V. (10µH inductor Murata LQH55DN100M).

Efficiency vs. V_L ($V_{IN} = 5V$, 10S6P at 20mA per LED)



Packaging Information

TQFN33-16

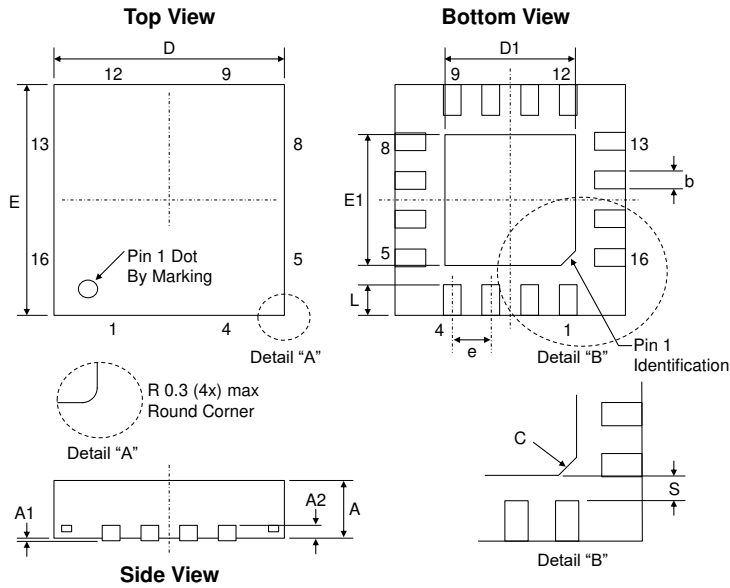

Dimension	mm		
	Min.	Typ.	Max.
A	0.65	0.75	0.85
A1	0.000	0.025	0.050
A2	0.154	0.203	0.280
b	0.18	0.23	0.30
C		0.3REF	
D	2.95	3.00	3.05
D1		1.7REF	
E	2.95	3.00	3.05
E1		1.7REF	
e	0.45	0.50	0.55
L	0.30	0.40	0.50
S		0.25REF	

Recommended Footprint

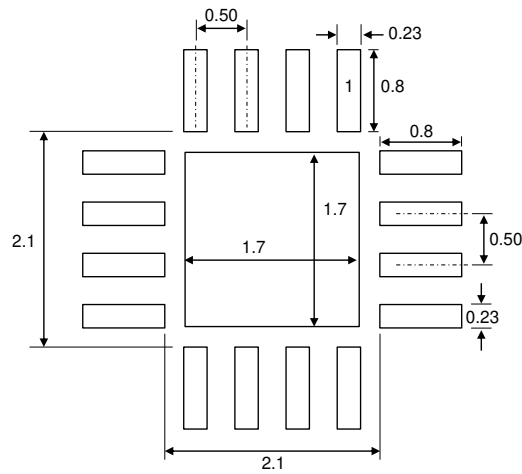

* Dimensions are in millimeters.

WLCSP-16 1.65mm x 1.65mm

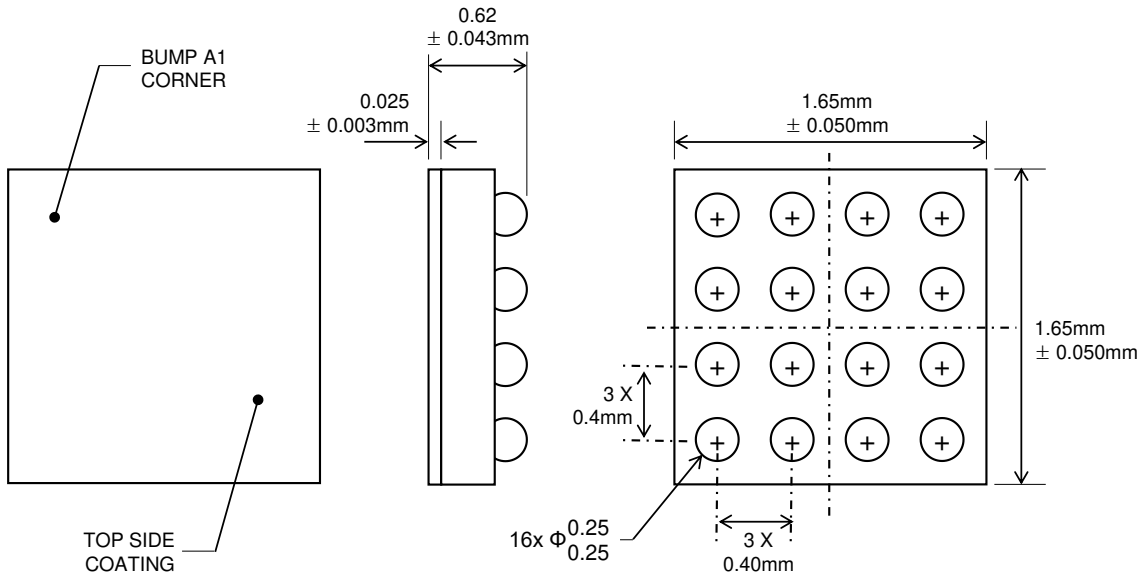

Recommended Footprint

(NSMD Pad Type)

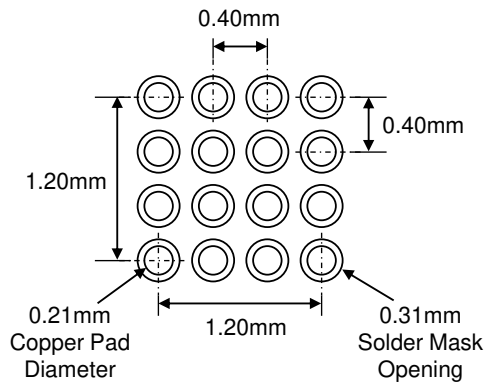

* Dimensions are in millimeters.

Kinetic Technologies cannot assume responsibility for use of any circuitry other than circuitry entirely embodied in a Kinetic Technologies product. No intellectual property or circuit patent licenses are implied. Kinetic Technologies reserves the right to change the circuitry and specifications without notice at any time.