

CRYSTAL OSCILLATOR SPXO

SG-710 series

- Frequency range : 1.8 MHz to 125 MHz
- Supply voltage : 3.3 V or 5.0 V
- Function : Output enable (OE) PTK,PHK
Standby (\overline{ST}) ECK
- Thickness : 1.3 mm Typ.



Product Number (please contact us)
Q33710xx0xxx00



Actual size



Specifications (characteristics)

Item	Symbol	Specifications			Remarks
		SG-710PTK	SG-710PHK	SG-710ECK	
Output frequency range	f_0	1.8 MHz to 50 MHz	1.8 MHz to 80 MHz	1.8 MHz to 125 MHz	
Supply voltage	V_{CC}	5.0 V ± 0.5 V			3.3 V ± 0.3 V
Temperature range	Storage temperature	-55 °C to +125 °C			Store as bare product after unpacking
	Operating temperature	-10 °C to +70 °C, -40 °C to +85 °C			
Frequency tolerance	f_{tol}	S: $\pm 25 \times 10^{-6}$, B: $\pm 50 \times 10^{-6}$, C: $\pm 100 \times 10^{-6}$ L: $\pm 50 \times 10^{-6}$, M: $\pm 100 \times 10^{-6}$			-10 °C to +70 °C -40 °C to +85 °C
Current consumption	I_{CC}	13 mA Max.	15 mA Max.	8 mA Max.	$f_0 \leq 25$ MHz, No load condition. (ECK: $f_0 \leq 32$ MHz)
		24 mA Max.	26 mA Max.	15 mA Max.	$f_0 \leq 50$ MHz, No load condition
		—	34 mA Max.	18 mA Max.	$f_0 \leq 67$ MHz, No load condition
		—	40 mA Max.	22 mA Max.	$f_0 \leq 80$ MHz, No load condition
		—	—	30 mA Max.	$f_0 \leq 125$ MHz, No load condition
Disable current	I_{dis}	6 mA Max.	5 mA Max.	—	$f_0 \leq 25$ MHz, OE=GND (PTK, PHK)
		12 mA Max.	10 mA Max.	—	$f_0 \leq 50$ MHz, OE=GND (PTK, PHK)
		—	13 mA Max.	—	$f_0 \leq 67$ MHz, OE=GND (PTK, PHK)
		—	16 mA Max.	—	$f_0 \leq 80$ MHz, OE=GND (PTK, PHK)
Stand-by current	I_{std}	—	—	13 μ A Max.	\overline{ST} =GND(ECK)
Symmetry	SYM	—	45 % to 55 %	45 % to 55 %	1.8 MHz $\leq f_0 \leq 50$ MHz, L_CMOS=15 pF(ECK), 50 % V_{CC}
		45 % to 55 %	40 % to 60 %	40 % to 60 %	50 MHz < $f_0 \leq 125$ MHz, L_CMOS=15 pF(ECK), 50 % V_{CC}
High output voltage	V_{OH}	2.4 V Min.	$V_{CC} - 0.5$ V Min.	90 % V_{CC} Min.	$I_{OH} = 16$ mA(PTK,PHK); 2 mA(ECK)
Low output voltage	V_{OL}	0.4 V Max.	0.5 V Max.	10 % V_{CC} Max.	$I_{OL} = 16$ mA(PTK,PHK), 2 mA(ECK)
Output load condition(TTL)	L_TTL	10 TTL Max.	10 TTL Max.	—	
Output load condition(CMOS)	L_CMOS	15 pF Max.	50 pF Max.	15 pF Max.	
Output enable / disable input voltage	V_{IH}	2.0 V Min.	2.0 V Min.	70 % V_{CC} Min.	OE terminal (PTK, PHK)
	V_{IL}	0.8 V Max.	0.8 V Max.	30 % V_{CC} Max.	\overline{ST} terminal (ECK)
Rise time / Fall time	t_r / t_f	—	5 ns Max.	6 ns Max.	CMOS load: 10 % V_{CC} to 90 % V_{CC} level
		5 ns Max.	—	—	TTL load: 0.4 V to 2.4 V level
Start-up time	t_{str}	10 ms Max.			Time at minimum supply voltage to be 0 s
Frequency aging	f_{aging}	$\pm 5 \times 10^{-6}$ / year Max.			+25 °C, $V_{CC} = 5.0$ V / 3.3 V, First year.

External dimensions

(Unit:mm)

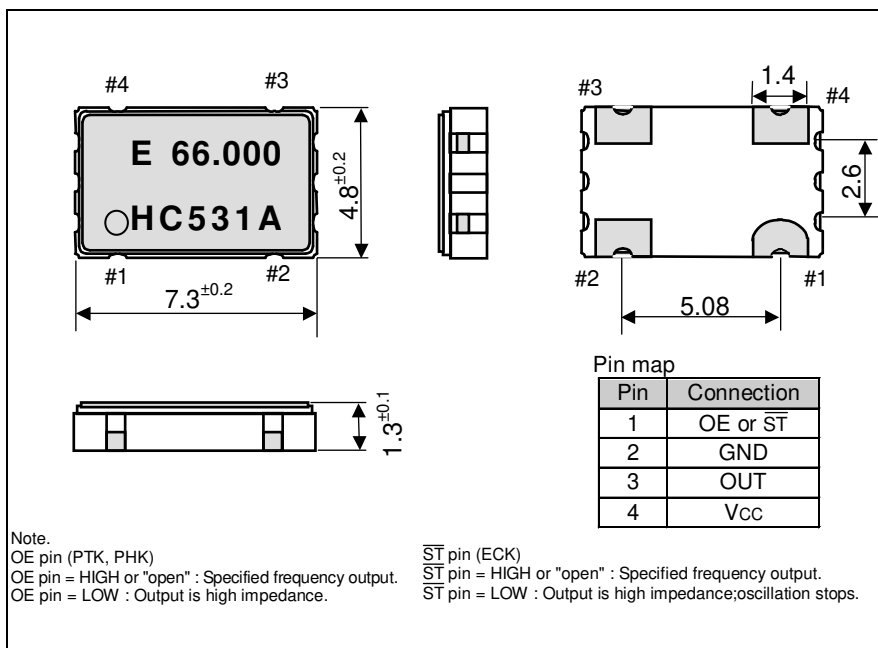

Footprint (Recommended)

(Unit:mm)

