

# molex®

## T2™ and Terminator Crimp Module 63801-8500 Instruction Manual

- Description
- Operation
- Maintenance

# Table of Contents



## Contents













T2™ and Terminator Crimp Module .....	1
Safety Warnings and Information.....	4
Tooling Technical Assistance .....	5
Principal Mechanical Parts of the Crimp Module .....	6
Section 1 .....	7
General Description .....	7
1.1.....Description .....	7
1.2.....Features.....	7
1.3..... Technical Specification .....	7
1.4.....Delivery Check.....	7
1.5.....Crimp Tooling Accessories (optional) .....	7
1.6.....Tools .....	7
1.7.....Application Tooling Specification Sheets .....	7
Section 2 .....	9
Set-Up and Operation.....	9
2.1.....Shut Height .....	9
2.2.....How to Manually Cycle the Press .....	10
2.3.....Crimp Module Installation and Removal .....	10
2.4.....Tool Set Removal and Installation .....	11
2.5.....A Quick Checklist Prior To The First Crimp .....	13
2.6.....Conductor Crimp Height Adjustment.....	14
2.7.....Insulation Crimp Height Adjustment.....	14
Section 3 .....	15
Troubleshooting .....	15
Section 4 .....	16
Adjustments .....	16
4.1.....Punch and Anvil Alignment.....	16
4.2.....Wire Stop Adjustment .....	16
4.3.....Rear Cover Adjustments.....	17
4.4.....Track Position Adjustment (T2 tools only).....	18
4.5.....Feed Finger Alignment.....	18
4.7.....Terminal Forward Feed Adjustment (Centering the Terminal to the Anvils) .....	20
4.8.....Back Stroke Feed Adjustments (Terminal pitch or spacing on the strip).....	20
4.9.....Crimp Tooling Installation and Removal .....	21
Section 5 .....	23
Maintenance .....	23
5.1.....Cleaning.....	23
5.2.....Lubrication .....	23
5.3.....Spare Parts.....	24
5.4.....Perishable Parts.....	24
5.5.....Crimp Module Storage .....	25
Section 6 .....	26
6.1.....Main Parts List .....	26
6.2.....Frame Assembly.....	28
6.2.....Feed Assembly .....	29



6.2.....Ram Assembly.....	30
6.3..... Terminator Set-up.....	31
Typical T2 Tool Set – Front Carrier (Figure 6-5).....	31
Typical T2 Tool Set – Dual Carrier (Figure 6-6).....	32
Typical T2 Tool Set – Rear Carrier (Figure 6-7).....	33
Typical Terminator Tool Set – Front Carrier (Figure 6-8).....	34
Typical Terminator Tool Set – Rear Carrier (Figure 6-9).....	35
Typical Terminator Tool Set – Dual Carrier (Figure 6-10).....	36
Typical Terminator Tool Set – Center Carrier (Figure 6- 11).....	37
“T” Micro Terminal (Figure 6-12).....	38

## Safety Warnings and Information

	<p><b>Read and understand</b> all of the instructions and safety information in this manual before operating or servicing this equipment.</p> <p style="text-align: center;"><u>Keep this manual available when using this equipment.</u></p> <p style="text-align: center;">Replacement manuals are available for download at <a href="http://www.molex.com">www.molex.com</a>.</p>
---	--

<b>SAFETY ALERT SYMBOL</b>	
<p>This symbol is used to call your attention to hazards or unsafe practices which could result in an injury or property damage. The signal word, defined below, indicates the severity of the hazard. The message after the signal word provides information for preventing or avoiding the hazard.</p>	
 <b>DANGER</b>	<p><b>DANGER:</b> Indicates an imminently hazardous situation which, if not avoided, could result in death or serious injury.</p>
 <b>WARNING</b>	<p><b>WARNING:</b> Indicates a potentially hazardous situation which, if not avoided, could result in death or serious injury.</p>
 <b>CAUTION</b>	<p><b>CAUTION:</b> Indicates a potentially hazardous situation which, if not avoided, may result in minor or moderate injury. <b>CAUTION</b> may also be used to alert against unsafe practices associated with events that could lead to personal injury.</p>

	<p> <b>WARNING</b></p> <p><b>Always</b> wear proper eye protection when Operating or servicing this equipment.</p> <p>Failure to wear eye protection could result in serious eye injury from flying debris.</p>		<p> <b>WARNING</b></p> <p>Excessive noise levels. <b>Always</b> wear proper ear protection when Operating or servicing this equipment.</p>
	<p> <b>WARNING</b></p> <p><b>Never</b> wear clothing or jewelry that is loose or that could potentially enter the equipment and get caught.</p> <p>Failure to observe this warning could result in severe injury or death.</p>		<p> <b>WARNING</b></p> <p><b>Never</b> install or service the press while connected to any electrical power source. Disconnect power by unplugging the press from its power source.</p> <p>Failure to observe this warning could result in severe injury or death.</p>
	<p> <b>WARNING</b></p> <p><b>Never</b> operate, service, install, or adjust this equipment without proper instruction or without first reading and understanding the instructions in this manual and all applicable press manuals.</p>		<p> <b>WARNING</b></p> <p><b>Always</b> hand cycle the module in the press to ensure the tooling is properly aligned.</p> <p>Failure to observe these precautions may result in injury or property damage.</p>

	<p><b>WARNING</b></p> <p><b>Never</b> use this equipment in a press or wire processing machine without guards or safety devices that are intended to prevent hands from remaining in the die space. This equipment is supplied with no guards and is intended to be used with the guards the press and/or the wire processor. Failure to observe this warning could result in severe injury or death.</p>		<p><b>WARNING</b></p> <p><b>Do not use</b> compressed air to clean the equipment. The forces created by compressed air can force debris into the tool.  Failure to observe these precautions may result in injury or property damage.</p>
<p><b>CAUTION</b></p>			
<p>The Molex Crimp Module is designed to operate ONLY in the TM-3000 and TM-4000 press with standard shut height at 135.80mm (5.346"). Installation in crimp presses with other than standard shut heights can cause severe tool damage. Check the shut height of the crimp press before operating the Crimp Module. Molex will not be liable for any damages as a result of installation in a crimp press with nonstandard or improperly set shut height. Failure to observe these precautions may result in injury or property damage.</p>			
<p><b>CAUTION</b></p>			
<p><b>Never</b> perform any service or maintenance other than as described in this manual. <b>Never</b> modify, alter or misuse the equipment Molex crimp specifications are valid only when used with Molex terminals, applicators and tooling. Failure to observe this precaution may result in injury and property damage.</p>			

## Tooling Technical Assistance

Molex offers tooling technical assistance for customers who may need some guidance for tooling adjustments. This support can be obtained by calling either of the two numbers listed below and asking for the Molex Tooling Group. Call Toll Free 1-800-786-6539 (US) 1-630-969-4550 (Global).

This assistance is limited to the operation and set-up of Molex application tools. Questions with regard to Molex connector products or how to identify the proper tooling and/ or tooling documentation should be directed to your local Molex personnel or Customer Service Representative.

When calling for service on the applicator it is recommended to have the following: a copy of the Tooling Manual, the specific Application Tooling Specification and a person familiar with the application tool should be present. The following information is also recommended to supply:

1. Customer name
2. Customer address
3. Person to contact such as (name, title, e-mail, and telephone number)
4. order number (Lease number also if applicable)
5. Serial number (Lease number also if applicable)
6. Molex Connector product order number
7. Urgency of request
8. Nature of problem

**Molex Application Tooling Group**

2200 Wellington Court  
Lisle, IL 60532, USA  
Tel: +1 (630) 969-4550  
Fax: +1 (630) 505-0049

Visit our Web site at <http://www.molex.com>

## Principal Mechanical Parts of the Crimp Module

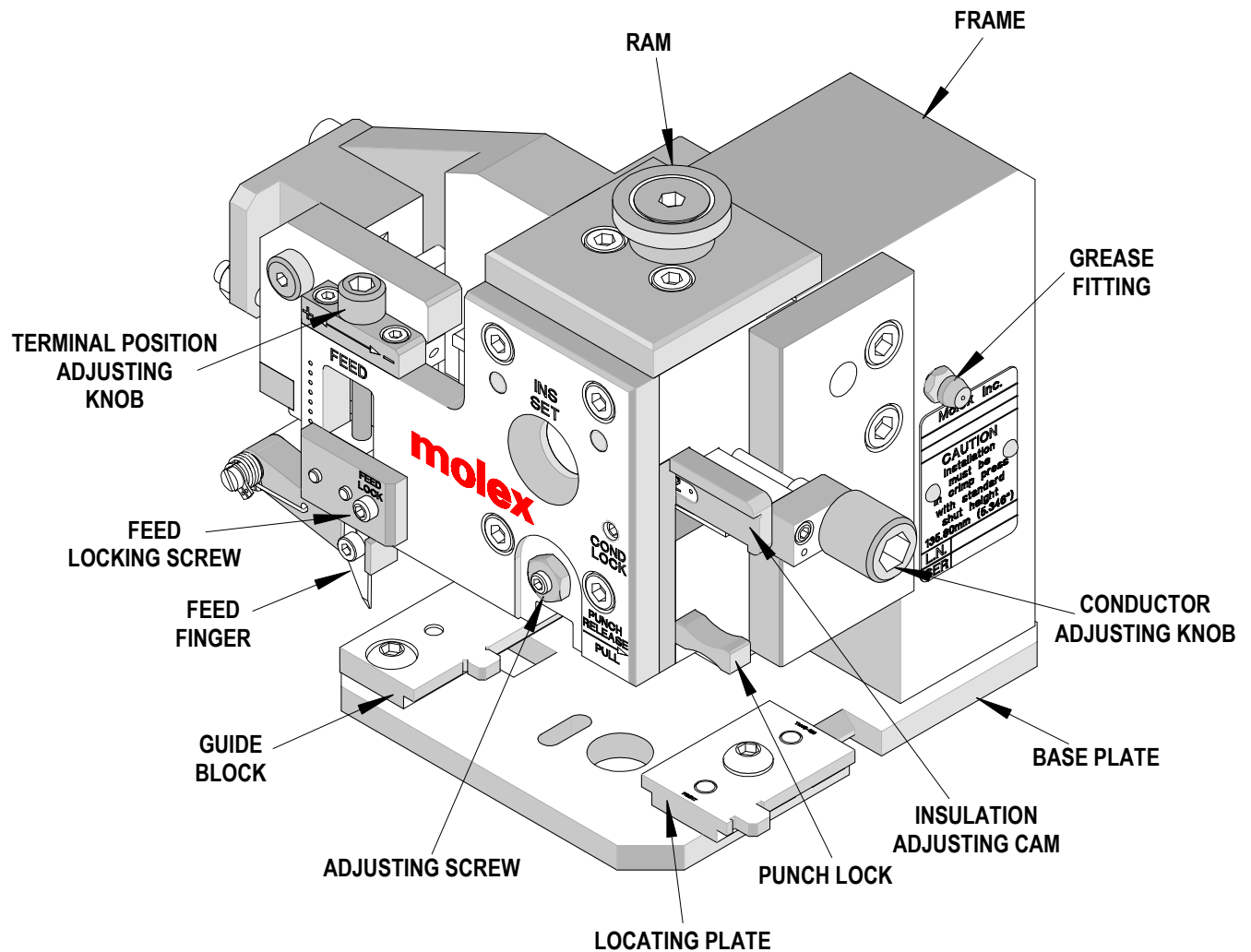

Figure 1-1

## Section 1

### General Description

#### 1.1 Description

The Molex T2™ and Terminator Crimp Module provides an effective method of transitioning T2 or Terminator tooling from the TM-40 or TM-42 press or Base Unit into the TM-3000 or TM-4000 press

This Crimp Module is installed ONLY in the Molex TM-3000 and TM-4000 Universal Presses. This unit will not work in other industry-standard presses. The Crimp Module features minimal setup time without the need for shimming, is versatile, reliable, easy to install, and is designed for mid-volume to high-volume, semi or fully automatic operations.

Molex offers the following presses for operating the Crimp Module:

- ✓ TM-3000 Press 120 V 60 Hz. **63801-7200**
- ✓ TM-3000 Press 240 V 50 Hz. **63801-7300**
- ✓ TM-4000 Press 240 V 60 Hz. **63801-7600**

#### 1.2 Features

- Fine adjustment allows users to achieve crimp height target by adjusting a wedge (0.74 mm total adjustment) for conductor crimp height and an 8-step cam (0.23mm per step) for insulation crimp height.
- Independent adjustment cams allow users to quickly adjust the conductor or insulation crimp height independently.
- Quick crimp punch removal.
- Compatible ONLY with the Molex TM-3000 and TM-4000 Universal Presses
- Automatic terminal feed (on ram upstroke only).
- Quiet operation; low maintenance and easy to keep clean.
- Accepts any Molex T2 or Terminator tooling.

#### 1.3 Technical Specification

##### Dimensions

##### (Crimp Module Only)

Width:	190mm	(7.5")
Depth:	121mm	(4.8")
Height:	146mm	(5.7")

##### Weight (Crimp Module Only)

4.1kg (9lbs)

#### Guarding

The Crimp Module is supplied with no guards and is intended to be used with the guards installed on the TM-3000 or TM-4000 press.



**Do not operate the Crimp Module without press guards installed.**

#### 1.4 Delivery Check

Carefully remove the Crimp Module from its shipping container; note that the following items are also included in the package:

TM-638018500 Operation Manual	1
Crimp Module with serial tag	1

#### 1.5 Crimp Tooling Accessories (optional)

Molex Order No. 63801-7240	Terminal Oiler (Appendix C)
Molex Order No. 63800-2820	Digital Crimp Micrometer
Molex Order No. 63817-0000	Hand Held Wire strippers
Molex Order No. 63801-9200	Pneumatic Bench Top Wire Strip Machine
Molex Order No. 63801-9250	Metric Bench Top Wire Strip Machine
Molex Order No. 63801-9100	Pull Force Tester Bench Top
Molex Order No. 63801-9700	Pull Force Tester Hand Held
Molex Order No. 63800-2810	Eye loupe

#### 1.6 Tools

The following tools are recommended for setup and adjustments to the applicator:

1. Metric and English hex wrench sets
2. Adjustable wrench
3. Wire stripper / cutter
4. Feeler gages/ shim stock
5. Eye loupe (5X)

#### 1.7 Application Tooling Specification Sheets

Molex ships specification sheets with all T2 or Terminator tooling. The specification sheet contains the following:

- E Terminal numbers
- E Wire AWG ranges
- E Insulation diameter ranges
- E Strip lengths
- E Pull force
- E Crimp heights
- E Bell mouth
- E Bend, twist, and roll limits
- E Tooling parts list and assembly

The specification sheets contain all the critical information on tooling replacement part numbers and inspection characteristics. Copies should be kept on hand and made available.

Application Tooling Specification and other Molex tooling documentation is available for download on the Molex website ([www.molex.com](http://www.molex.com)).

To find Application Tooling Specification sheets, go to [Molex.com](http://Molex.com). Using the “Search Box” on the main page, enter the desired tooling order number. When the tooling page comes up, go to the “Specifications & Other Documents” section and click on the “Application Tooling Specification” link.

**T2 Terminator Tooling**

**molex**

Application Tooling Specification Sheet

Order No. 63010-4000

**FEATURES**

- It is ideally suited for end volume bench operations.
- The terminator can be installed in the TMS2 and the TMS0 press or Base Unit adapter for 30T press.
- Quick punch removal with the push of a button for fast and easy loading change.
- Quick adjustment capabilities in the T2 terminators for improved control of the bell mouth size and contact length.
- T2 Terminator has standardized tooling with the Molex ForceQuick Applicator which will reduce your inventory requirements.

**SCOPE**  
Crimper: Micro # 3.0mm Crimp Terminal, Able end 1 wire, 26-30 AWG.

Terminal Series No.	Terminal Order No.	Wire Size	Insulation Diameter	Strip Length	Part No.	QTY	IN
4300	4300-0001	26-30	0.10-0.08	1.04-1.27	044-006	2,54-210	106-115
4301	4301-0001	26-30	0.10-0.08	1.04-1.27	044-006	2,54-210	106-115
4302	4302-0001	26-30	0.10-0.08	1.04-1.27	044-006	2,54-210	106-115

**DEFINITION OF TERMS**

The above terminal drawing is a generic terminal representation. It is not an image of a terminal listed in the scope.

Part No.	Quantity	Description	Quantity
044-006	1	TERMINATOR	1
044-006	1	TERMINATOR	1
044-006	1	TERMINATOR	1
044-006	1	TERMINATOR	1

**TERMINATOR PARTS LIST**

Part No.	Quantity	Description	Quantity
044-006	1	TERMINATOR	1
044-006	1	TERMINATOR	1
044-006	1	TERMINATOR	1
044-006	1	TERMINATOR	1

Figure 1

Doc No: AT3-62815493 Release Date: 06-17-07 UNCONTROLLED COPY Page 1 of 6  
Revision: C Revision Date: 09-30-10

Doc No: AT3-62815493 Release Date: 06-17-07 UNCONTROLLED COPY Page 2 of 6  
Revision: C Revision Date: 09-30-10

Doc No: AT3-62815493 Release Date: 06-17-07 UNCONTROLLED COPY Page 3 of 6  
Revision: C Revision Date: 09-30-10

Doc No: AT3-62815493 Release Date: 06-17-07 UNCONTROLLED COPY Page 4 of 6  
Revision: C Revision Date: 09-30-10

Doc No: AT3-62815493 Release Date: 06-17-07 UNCONTROLLED COPY Page 5 of 6  
Revision: C Revision Date: 09-30-10

Doc No: AT3-62815493 Release Date: 06-17-07 UNCONTROLLED COPY Page 6 of 6  
Revision: C Revision Date: 09-30-10

Doc. No: TM-638018500  
Revision: A

Release Date: 11-26-12  
Revision Date: 11-26-12

UNCONTROLLED COPY

Page 8 of 39



## Section 2

### Set-Up and Operation



Read the following instructions before attempting to operate the Crimp Module.

#### 2.1 Shut Height

The shut height for the Crimp Module is 135.80mm (5.346"). The shut height for the crimp press is calibrated using a Shut Height Gauge. See Figure 2-1. The gauge is designed to apply the proper load at 135.80mm (5.346") shut height. Molex offers an industry standard shut height gauge (order number 63800-7900) that will fit in the TM-3000 and TM-4000 crimp presses. It is recommended that the crimp press shut height be checked regularly.

The Crimp Module is designed to operate in the TM-3000 and TM-4000 crimp presses with standard shut height of 135.80mm (5.346"). Installation in crimp presses with non-standard shut heights or ram strokes greater than 30mm can cause severe tool damage. It is recommended before installation, a check of the shut height be performed. The correct shut height is required to prevent the punches from hitting the anvils and the cut-off tooling from crashing. Calibrated presses also allow various T2 and Terminator tools to be installed with minimal adjustment to the Crimp Module.

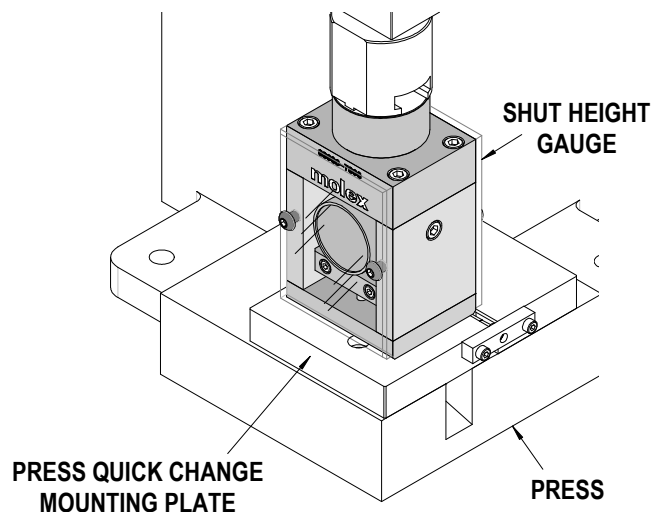

Figure 2-1

#### Measuring Press Shut Height



**Always** turn off and disconnect the power supply to the press.

1. Open the guard door.
2. Remove the applicator or Crimp Module from the press. See Section 2.3 *Module Installation and Removal* for additional information. Clean the bottom of the press ram and top of the quick change mounting plate.
3. Place the shut height gauge onto the press quick change mounting plate. Align the gauge to the ram as shown in Figure 2-1.
4. Manually cycle the press to the down stroke position. See Section 2.2, *How to Manually Cycle the Press*, or follow the TM-3000 Operation Manual (order number TM638017299) Section 3.3 *Manually Cycling the Press*.
5. Read the shut height measurement from the front of the gauge. Follow the gauge manufacturers' instruction; usually the gauge reads "0" when shut height is 135.80mm (5.346").
6. If adjustments are necessary, refer to the TM-3000 press manual for adjustment of the press shut height.
7. Repeat the above steps until the correct shut height is obtained.
8. Shut height gauges must be calibrated on a regular basis.

## 2.2 How to Manually Cycle the Press



**Always** turn off and disconnect the power supply to the press.



**Always** hand cycle the Crimp Module in the press to ensure the tooling is properly aligned.

**Note:** When the press guard is open make sure the power is disconnected from the motor (MOTOR ON light is not illuminated)

Hand cycling the press is necessary to confirm correct tool alignment and terminal feed adjustment. It also allows personnel to observe the crimping cycle in slow-motion.

### Manually Cycling the TM3000 and TM4000 Presses

1. Insert the hand-cycle T wrench (furnished with the press) through the access hole in the center of the motor's rear cover and locate it on the motor shaft. See Figure 2-2.
2. Rotate the wrench clockwise. This turns the motor and moves the ram down and up.
3. Always return the press ram back to top dead center to ensure that the ram is in the startup position.
4. Remove the T-handle wrench.



**NOTE:** When the T-handle wrench is inserted onto the motor shaft the power is automatically disconnected from the motor. Press the green MOTOR ON button to restore power to the motor.

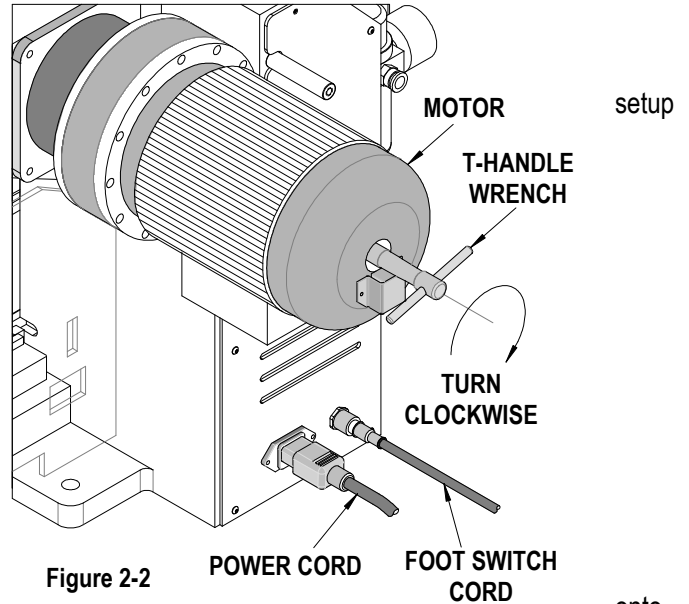

Figure 2-2

## 2.3 Crimp Module Installation and Removal



**Always** turn off and disconnect the power to the press.

### Installation

1. Open the press guard door.
2. Clean the quick change mounting plate of scrap or chips that may interfere with the Crimp Module installation.



Molex recommends a soft brush; **do not use** compressed air to clean the equipment. The forces created by compressed air can force debris into the tool.

3. To install the Crimp Module, follow the procedure below:
  - a. Using a 4mm hex wrench, turn the M5 socket head cap screw clockwise until the locking clamp is fully opened.
  - b. Slide the Module's lug bolt into the press ram yoke.
  - c. Pull the Crimp Module's frame down until the Module's base plate rests on the quick change mounting plate.
  - d. Visually align the Crimp Module's base plate notches on the left with the location clamps on the press quick-change mounting plate.
  - e. Slide the Crimp Module to the left until the two notches in the base plate engage against the location clamps. See Figure 2.3.
  - f. To lock applicator, turn the M5 socket head cap screw counterclockwise until tight.

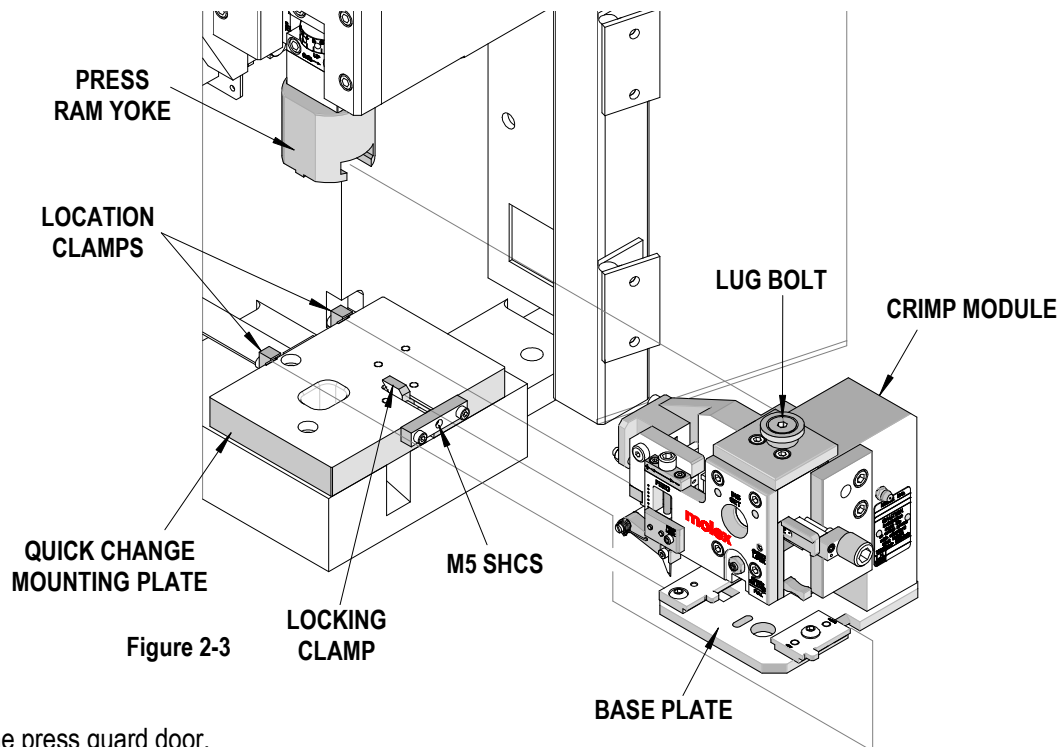

Figure 2-3



- 4 Close the press guard door.
- 5 Hand cycle the press. See Section 2.2 *How to Manually Cycling the Press*.
- 6 Reconnect power and press the green MOTOR ON button.

### Removal

Remove the Crimp Module by reversing the previous steps. When storing the Module, always leave a strip of terminals in the Module's track to prevent damage to the tooling. See Section 5.5 *Storage*.

## 2.4 Tool Set Removal and Installation



**Power must be disconnected from the press. Manual press cycling (hand cycling) is absolutely required for safety and preventing equipment damage. Always hand cycle when trouble shooting or changing adjustments, tooling, terminal reel, crimp module, or accessories.**

### Tool Set Removal

1. Disconnect power and open the guard door.
2. Set both the conductor and insulation cams to their highest (loosest) setting.  
For the conductor cam, loosen the COND LOCK set screw on the ram face plate. Turn the conductor adjusting knob counterclockwise until it stops.  
For the insulation cam, slide it all the way to the left.
3. Remove the M6 button head cap screw and remove the right locating plate.
4. Lift the feed finger clear and slide the terminator die out of the Crimp Module.
5. Remove the punches, nose hold-down, rear striker, and center carrier cutoff tooling from the ram.
6. The terminator tooling is best stored in its original container.

### Tool Set Installation



Make sure the proper crimp tooling is used for the terminal. Find the terminal part number on the terminal reel label and compare it to the Application Tooling Specification sheet for the tooling. All Molex crimp tooling has an Application Tooling Specification sheet.

Before any die is installed make sure the cover alignment procedure and the track adjustment procedure, (when applicable) have been completed. See the specific terminator die instruction manual for these procedures.

1. Power down the press and open the guard door.
2. Some crimp tools may have nose hold down, rear strikers, or center carrier cutoff tooling. If these items are used, attachment points are located behind the punches either in the front or on the bottom of the Crimp Module's ram. Refer to the Specification sheet supplied with each individual terminator die for parts supplied with that terminator.
3. Fit the (2) punches in the opening on the underside of the ram. The conductor punch is positioned in the rear. See Figure 6-5. A click will be heard when the punch retaining/release pin engages the slots in the punches
4. Set both the conductor and insulation cams to their highest (loosest) setting.
5. The front plunger striker mounts in front of the insulation crimp punch and is attached with a #10-32 set screw and hex nut through the hole in the ram's face plate. The set screw is adjusted to minimize punch float.
6. Clean the Crimp Module's base plate of debris or chips that may interfere with the tool set installation.
7. Remove the right locating plate from the bolster plate by removing the M6 button head cap screw.
8. Lift the feed finger clear and slide the terminator track notch onto the left locating plate.
9. Attach the right locating plate against the anvils and tighten the M6 button head cap screw.



**Always** hand cycle the Crimp Module after installing tooling to ensure proper tool alignment.

### Loading and Unloading the Terminal Strip

1. The specified terminals are printed on the specification sheet for the Terminator. Only use the Molex terminals on the specification sheet which is supplied with the Terminator.



**Always** turn off and disconnect the power supply to the press when loading or unloading terminals

2. Install the terminal reel on the press reel arm and unwind about 400mm (15 in.) of terminals off the reel.

**CAUTION:** Terminals and terminal carrier strips may have sharp edges. Use caution while handling terminals.

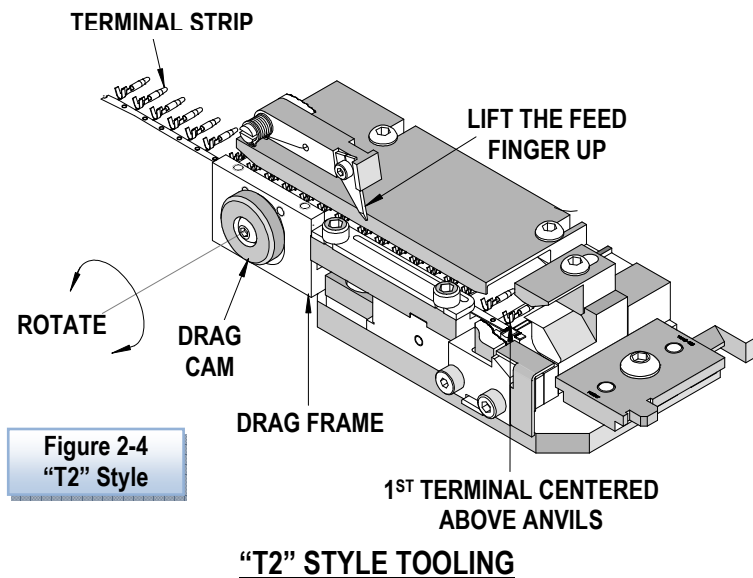

Figure 2-4  
"T2" Style

1. If using a T2 Terminator, rotate the drag cam until the drag frame is in the upright position. This will allow the terminal to slide easily through the terminal track. See Figure 2-4.
2. Push the terminal strip through the track until the first terminal comes to rest centered above the crimp anvils.
3. If severe resistance is encountered or the terminal strip does not fit, a rear cover adjustment may be needed. See Section 4.3
4. Rotate the drag cam to engage the terminal drag frame.
5. Cycle the press by hand so that the feed finger transfers the next terminal to a centered position over the crimp anvils. Check that all other parts slide and engage without any interference. The press should be hand cycled several times.
6. When unloading the terminal strip, make sure the power is turned off and disconnected from the press.

7. Rotate the drag cam until the drag frame is in the upright position.
8. Raise feed finger and pull terminal strip backwards until disengaged from applicator track. See Figure 2-4. If preferred, cut the terminal carrier strip and pull it forward through the applicator track with needle nose pliers.
9. Close the guard door and restore power to the press.

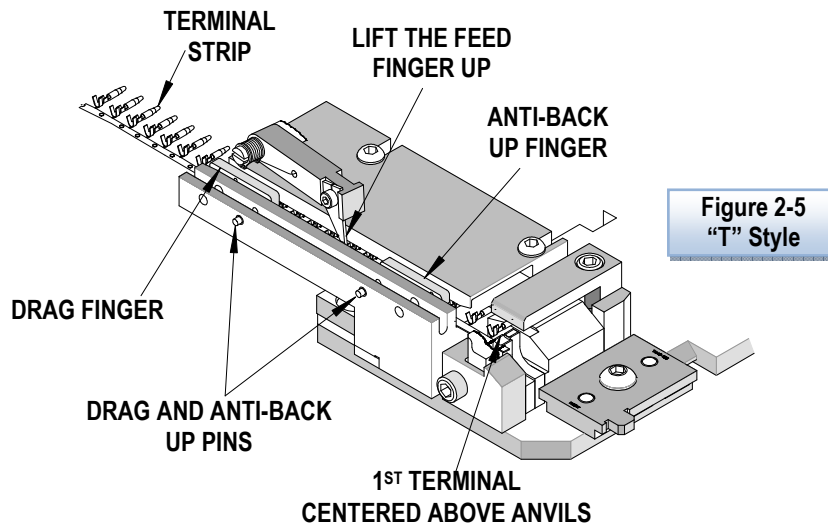

Figure 2-5  
"T" Style

### "T" (TERMINATOR) STYLE TOOLING

1. If using a "T" style Terminator, push both the drag and anti-backup pins located on the front of the terminator die. This will allow the terminals to slide freely through the terminal track. See Figure 2-5.
2. Push the terminal strip through the track until the first terminal is centered above the crimp anvils. If severe resistance is encountered or the terminal strip does not fit, a rear cover adjustment may be needed. See Section 4.3.
3. Release the terminal drag and anti-backup pins to engage the terminal drag frame on the track.
4. Hand-cycle the press so the feed finger transfers the next terminal to a centered position over the crimp anvils.
5. Check that all other parts slide and engage without any interference. The press should be hand cycled several times.
6. When unloading the terminal strip, make sure the power is turned off and disconnected from the press.
7. Raise terminal drag finger and anti-backup finger from the carrier strip.
8. Lift the feed finger and pull terminal strip backwards until disengaged from terminator track. If preferred, cut the terminal carrier strip and pull it forward through the terminator track with needle nose pliers.
9. Close the guard door and restore power to the press.

## 2.5 A Quick Checklist Prior To The First Crimp

The T2 and Terminator tooling is modular and can be installed and immediately operated, however preventive measures should be practiced to assure safe operation and prevent accidental tooling damage.



In many cases, T2 and terminator tooling can crimp various Molex terminals. The terminal tested and shipped with the tooling may not be the actual terminal (or the actual wire) the customer is using. This may require some minor adjustments BEFORE crimping under press power.



1. The Crimp Module must be hand-cycled to verify there is no mechanical interference.
2. Verify mechanical function
  - Terminal cutoff, single terminal feed, and crimped terminal is ejected.
3. Never operate the Crimp Module if there is a feed problem. Correct this first and proceed with setup.
  - Verify the Crimp Module feeds terminals perfectly to the anvil center.
  - Fine tuning of the terminal feed may be required depending on the application.
4. Inspect the crimps according to the Application Tooling Specification sheet.
5. Adjust conductor and insulation crimp heights accordingly. See Section 2.6 and 2.7.

## 2.6 Conductor Crimp Height Adjustment

1. With the guard door closed, place a stripped length of suitable wire into the terminal and crimp the wire under power. Strip length for the wire can be found in the Application Tooling Specification shipped with the tooling, or downloaded from the Molex website.
2.  Inspect the quality of conductor crimp and measure the crimp height. A crimp micrometer should be used (order no. 63800-2820); refer to the Crimp Quality Manual (document no. TM-638000029), Section 7. If adjustments are necessary, disconnect the power from the press. Open the guard door. The desired crimp height can be achieved by loosening the COND LOCK screw and turning the turning conductor cam adjusting knob clockwise to lower the crimp height or counterclockwise to raise the crimp height. Tighten the COND LOCK screw to prevent the conductor crimp adjustment from moving. See figure 2-6. The conductor adjusting knob should be adjusted in one-turn increments.

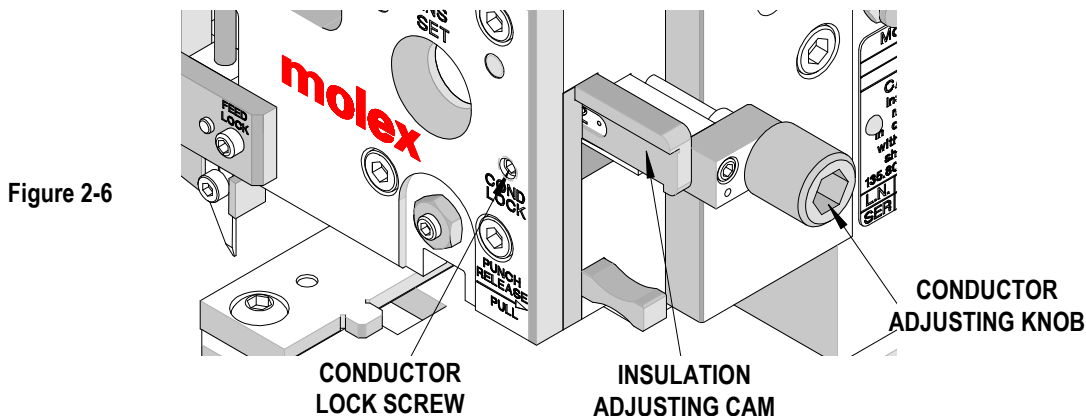

3. Close the guard door and repeat steps 1 – 3 until the desired crimp height is obtained. See the Crimp Quality Manual (document no. TM-638000029), Section 7 for more information.
4. Perform a pull test on conductor crimp to verify the mechanical integrity of the crimp. Refer to the Molex Pull Force Tester (order nos. 63801-9100 and 63801-9700) Application Tooling Specification Sheets or the Crimp Quality Manual for basic pull force instructions.

## 2.7 Insulation Crimp Height Adjustment

1. Place a stripped length of the appropriate wire into the terminal and crimp under power.
2. Observe the quality of the insulation crimp and measure the crimp height. See the Crimp Quality Manual for more information.
3.  If adjustments are necessary, always turn off and disconnect the power supply from the press. Open the guard door.
4. Slide the insulation-adjusting cam and observe the number in the window below INS SET to achieve the desired insulation height.

**Each increment represents approximately 0.23mm (.009") for a total adjustment of 1.60mm (0.063"). The "1" setting is for the loosest (tallest) crimp height and the "8" setting the tightest (smallest) crimp height.** It is recommended that the customer start with the loosest setting which is "1", and make test crimps until the proper insulation crimp height is achieved.

5. Repeat the steps 1 – 3 until the desired insulation crimp height is obtained.

**Note:** Due to the large variety of insulation wall thickness, materials, and hardness, insulation crimp height is not typically specified. For each different wire type, the insulation crimp height can be measured, recorded, and inspected as a quality indicator.

**Different applicator options are available, listed on [molex.com](http://molex.com), to better achieve optimal crimps for various wire insulation types**

## Section 3

### Troubleshooting

Symptom	Cause	Section	Solution
Terminals not feeding	▪ Terminal strip bent or damaged		Replace terminals.
	▪ Feed finger worn or not properly adjusted	4.5	Check proper finger setting
	▪ Drag plate not holding terminal strip		Check compression springs and close the drag.
	▪ Feed finger not moving back enough to pick up the terminal (pitch)	4.8	Set terminal feed backstroke.
	▪ Terminal jammed under cover plate		Clear and reload terminal strip
Excessive Bell mouth	▪ Conductor punch worn	4.9	Replace punch.
	▪ Track out of position	4.4	Adjust base and track for proper alignment with the punches and anvil.
Cut-off plunger does not return to original position	▪ Cut-off plunger retainer screws over-tightened		Reduce tightening torque on screws
	▪ Cut-off plunger spring damaged or broken		Replace spring per specification sheet.
	▪ Cut edges worn or damaged	4.9	Remove scoring marks. If problem not solved, replace with new tooling.
	▪ Plunger, retainer, and insulation anvil		
Conductor crimp is too loose	▪ Wrong tooling	4.9	Replace per specification sheet.
	▪ Tooling worn or damaged	4.9	Replace per specification sheet.
	▪ Wrong cam setting	2.6	Measure crimp height and adjust accordingly.
	▪ Press shut height too high	2.1	Adjust press shut height to 135.8mm
Conductor crimp is too tight	▪ Wrong tooling	4.9	Replace per specification sheet.
	▪ Cam out of adjustment	2.6	Measure crimp height and adjust accordingly.
	▪ Press shut height is too low	2.1	Adjust press shut height to 135.8mm
Insulation crimp is too tight	▪ Cam out of adjustment	2.7	Readjust insulation cam.
	▪ Wrong tooling	4.9	Replace per specification sheet.
	▪ Press shut height is too low	2.1	Adjust press shut height to 135.8mm
Terminal sticks during crimping	▪ Wrong tooling	4.9	Replace per specification sheet.
	▪ Tooling worn or damaged	4.9	Replace per specification sheet.
	▪ Crimp height too low	2.6	Measure crimp height and adjust accordingly.
	▪ Gold plating and/or some high tensile materials	Appendix	Install a terminal oiler.
Terminals bent up or down	▪ See causes for "terminals sticking"		
	▪ Track set too far in or too far out	4.4	Adjust track.
	▪ Nose hold down misadjusted or missing.		Refer to specification sheet (if applicable)
Crimp extrusion)	▪ See causes for "conductor crimp too tight"	2.6	
	▪ Gold plating and/or some high tensile materials	Appendix	Install a terminal oiler.
	▪ Wrong tooling	4.9	Replace per specification sheet.
	▪ Tooling worn or damaged	4.9	Replace per specification sheet.
Wire brush inconsistent	▪ Wire stop out of adjustment	4.2	Adjust accordingly.
	▪ Wire stop missing	1.7	Replace per specification sheet.
	▪ Operator applying too much force against wire stop		Adjust method of presenting wire into the machine.
Insulation crimps do not provide strain relief (IPC- A620)	▪ Verify wire insulation diameter is within the range of the terminal (specification sheet)	2.7	Adjust accordingly or see if alternate tooling is available at molex.com.

## Section 4

### Adjustments

There are many adjustments on the Crimp Module. Be aware of what adjustments are made to the Module, as making one adjustment can sometimes influence another. For example, moving the track for a bell mouth adjustment may require the feed finger to be realigned. It is best practice to have frequent five minute preventive maintenance checks and cleanings before and after each use. Regular cleaning, lubrication, spot checks for tooling wear, and alignment can prevent production problems and allow time for replacement parts to be delivered if needed.

#### 4.1. Punch and Anvil Alignment

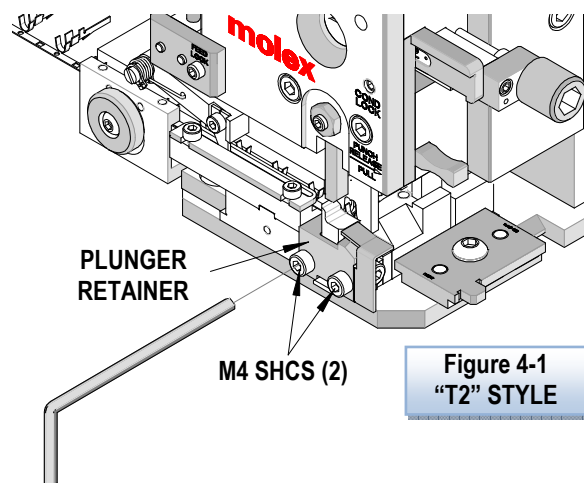

Figure 4-1  
"T2" STYLE

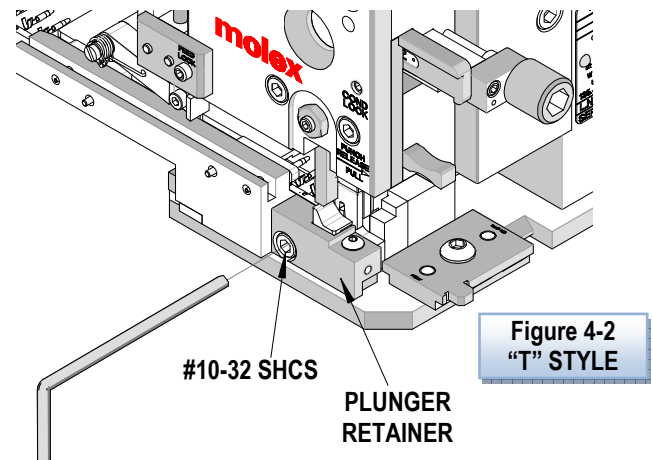

Figure 4-2  
"T" STYLE

Note: Always clean mounting surfaces of crimp tooling and tooling holders prior to alignment.



**Do not use** compressed air to clean the equipment.  
The forces created by compressed air can force debris into the tool.  
Failure to observe these precautions may result in injury or property damage.

1. Disconnect the power supply from the press. Open the guard door.
2. With a terminal centered over the anvils, slightly release anvil mounting screw. See Figures 4-1 and 4-2.
3. Place the hand cycling wrench through the access hole in the press motor's rear cover.
4. Slowly lower the press ram until it is in the fully down position. With the terminal resting on the anvils the punch will align the bottom tooling.
5. While the ram is fully down, tighten the anvil mounting screws to ensure exact alignment of punches and anvils. Tighten center carrier cut-off tooling if applicable.
6. Use the hand cycle wrench to bring the ram back to top dead center.
7. Close the guard door and restore power to the press.

#### 4.2. Wire Stop Adjustment

The wire stop is used to control the amount of conductor brush beyond the conductor crimp grip.

For automatic wire processing machines, the wire stop can be moved back and used to assist in the stripping of the terminal from the crimp punches. However, in certain circumstances the wire stop may need to be completely removed when running on an automated machine.

1. Check the Application Tooling Specification sheet to obtain the correct wire strip length.
2. Place the correct wire gauge that is properly stripped into the terminal and crimp the wire under power. Prior to crimping under power make sure the tooling has been hand-cycled. See Section 2-1 *How to Manually Cycle the Press*.
3. Observe quality of crimp and the wire insulation and brush position.



4. If adjustments are necessary, turn off the press. Open the guard door.
5. Hand cycle the press to lower the ram.
6. On the T2 tooling, use a 4mm hex wrench to loosen the M5 socket head cap screw located on the side of the anvil mount. See Figure 4-3.
7. For some T2s and Terminator ("T" style) tooling, the wire stop mounting screw may be located on top of the anvil mount.

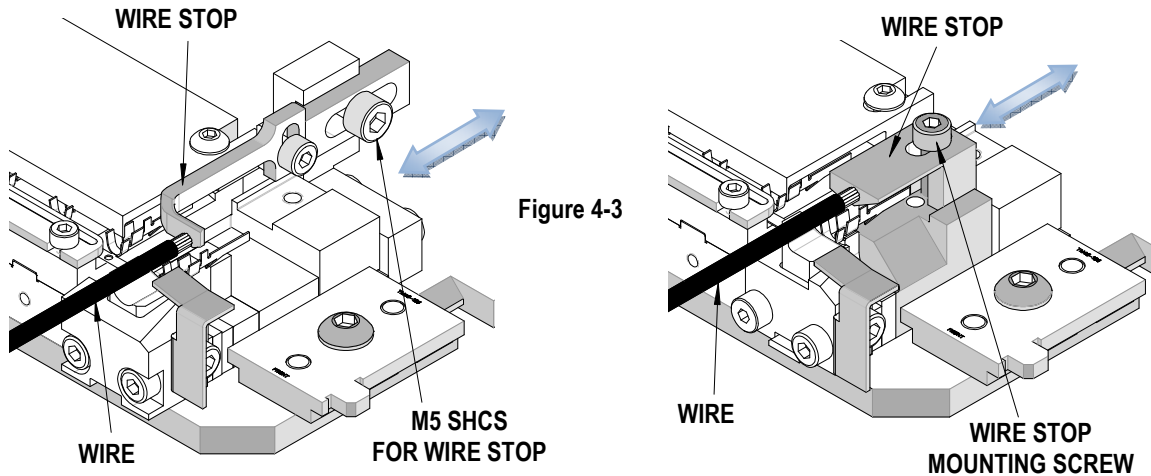

Figure 4-3

8. Adjust the position of the wire stop by moving the wire stop towards the operator to decrease the brush length and towards the press to increase it.
9. Feeler gauge or shim stock can be used to create a gap between the back of the conductor punch and front of the wire stop. The amount of shim used here is directly related to the amount of wire brush.
10. Tighten the M5 socket head cap screw.
11. Hand cycle the press to ensure the conductor punch does not hit the wire stop. Then crimp a terminal under power and observe the quality of the termination.

### 4.3 Rear Cover Adjustments



**Always** turn off and disconnect the power supply to the press before making adjustments.

1. Disconnect the power from the press. Open the guard door.
2. Remove the terminator from the Crimp Module. See Section 2.3, *Crimp Module Installation and Removal*
3. For the T2 style tooling, rotate the drag cam until the drag frame is in the upright position.
4. With an 8-10" long strip of terminals installed in the track, push the rear cover towards the front of the track to eliminate any excessive play between points 1 and 2. See Figure 4-4.

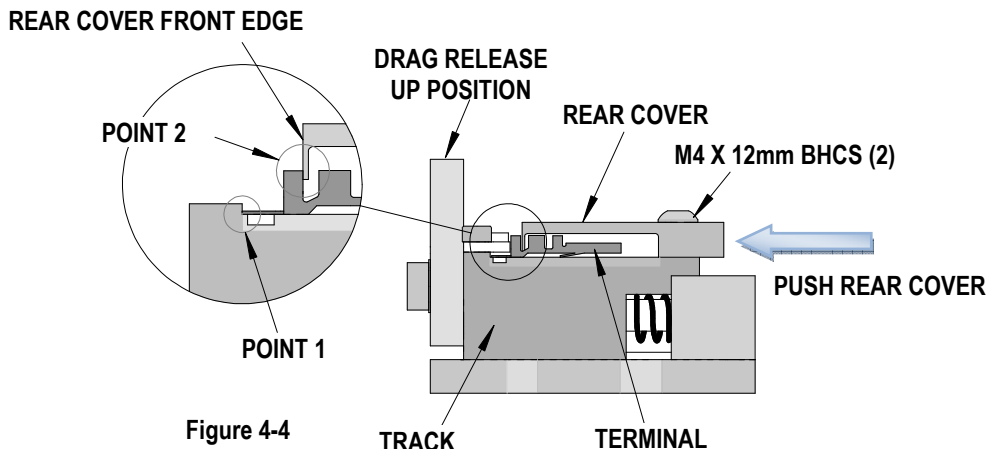

Figure 4-4

5. Slide the strip of terminals forward and back while lightly pushing the rear cover towards the front of the track. The goal is to have minimal movement between points 1 and 2, but still allow the strip of terminals to slide freely.

6. After the correct position is achieved, tighten the two M4 button head cap screw (T2) or #8 button head cap screw (“T” style) and remove the strip of terminals.
7. Re-install the terminator in the Crimp Module. See Section 2.3, *Crimp Module Installation and Removal*

#### 4.4 Track Position Adjustment (T2 tools only)



Disconnect the power supply to the press.

1. Open the guard door.
2. Depending on the amount of movement, the feed finger mount may need to be loosened and readjusted. See Section 4.5 *Feed Finger Alignment*.
3. Determine which way the track needs to move. To decrease front cut-off tab or to increase bell mouth, the track should be adjusted toward the operator. The track is usually adjusted toward the press to decrease bell mouth or to help straighten a bend-up condition.
4. Remove the Crimp Module from the press. See Section 2.3.
5. To position the terminal track in or out, use a 4mm hex wrench to loosen the M5 lock screw located on the underside of the track. This screw can be accessed through a slot in the Crimp Module's base plate. See Figure 4-5.
6. Slide the track in or out to the desired position.

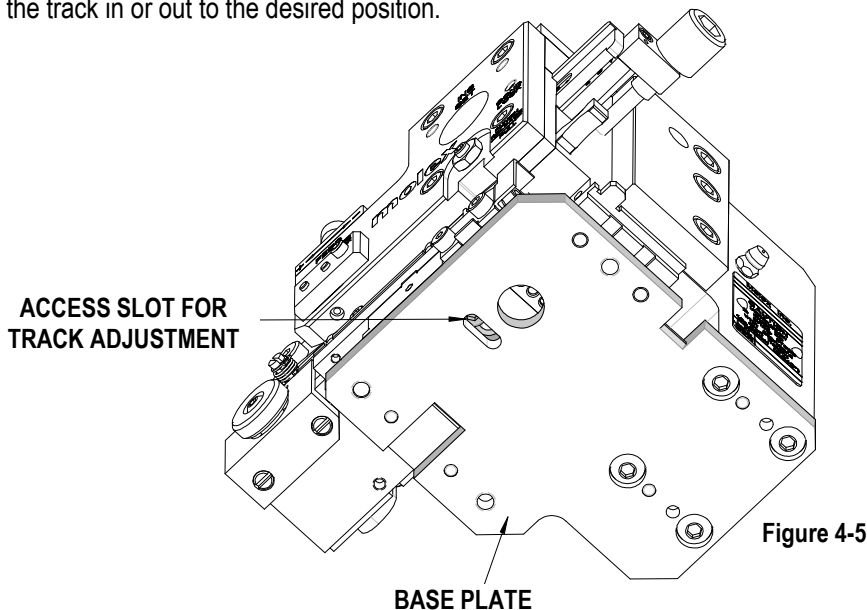

Figure 4-5

7. To lock the track in position, tighten the M5 lock screw.
8. Slide a length of terminal strip through the track and make sure it feeds freely into the cutoff plunger(s).
9. If the feed finger mount was loosened during the track positioning, remember to tighten its mounting screw.
10. The wire stop may need to be re-adjusted for insulation and brush position. See Section 4.2 *Wire Stop Adjustment*.
11. Hand cycle the press to ensure the terminal is positioned properly on the anvils and does not have an excessive cutoff tab. See Section 4.6 *Terminal Position Adjustment*. Also, verify the terminal feed operation.
12. Close the guard door and remove the hand-cycle wrench from the motor.
13. Restore power to the press, crimp a terminal under power, and observe the quality of the termination.
14. Repeat the above steps until the desired terminal position is obtained.

#### 4.5 Feed Finger Alignment



**Never operate the Crimp Module if there is a feed problem. Tooling damage can result. Adjust the insulation and conductor adjusting cams to create a loose crimp while solving feed problems. (Move the insulation cam to to the #1 position and turn the conductor adjusting screw CCW until the conductor cam stops.)**

1. Typically, terminals are fed by the carrier strip pilot hole. In this case, position the feed finger to align to the center of the carrier strip pilot hole. See Figure 4-6.

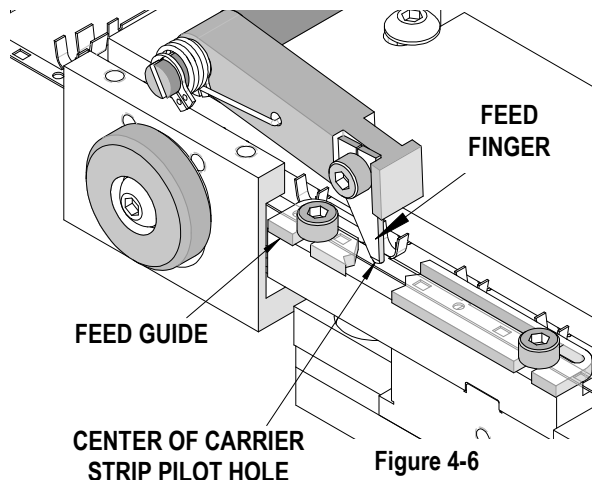

Figure 4-6

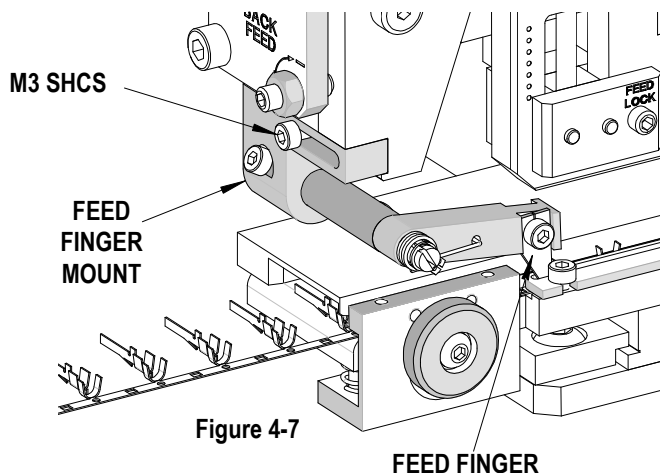

Figure 4-7



2. Disconnect power from the press. Open the guard door.
3. Using a 2.5mm hex wrench, loosen the M3 socket head cap screw located on the slotted hole of the feed finger mount. While raising the feed finger slightly, slide the feed finger to the desired position. See Figure 4-7.
4. If the feed finger mount cannot be moved far enough, remove the M3 socket head cap screw completely and install it in the next tapped hole in the feed lever.
5. Tighten the M3 socket head cap screw to lock the feed finger in position.
6. Hand cycle the press to verify proper feed operation.
7. Close the guard door, remove the hand-cycle wrench from the motor, and restore press power.

#### 4.6 Feed Finger Spring Tension

The feed finger is held against the terminal strip by force created from a torsion spring. If the force is too low, the feed finger may “skip” over the terminal strip and result in no feeding or partial feeding.

1. Disconnect power from the press. Open the guard door.
2. Use a small regular screwdriver in the slot of the feed finger pivot shaft to keep the torsion spring from unwinding. See Figure 4-8.
3. Using a 2.5mm hex wrench, loosen the M3 socket head cap screw holding the pivot shaft.
4. Turn the screwdriver clockwise to increase the tension of the torsion spring or counterclockwise to decrease it. Turn in small increments (30°) to avoid damaging the spring.
5. While holding the pivot shaft from turning, tighten the M3 socket head cap screw.
6. Since the pivot shaft can move axially when loosened, check the feed finger alignment and adjust if necessary.
7. Hand cycle the press to verify proper feed operation.
8. Close the guard door, remove the hand-cycle wrench from the motor, and restore press power.

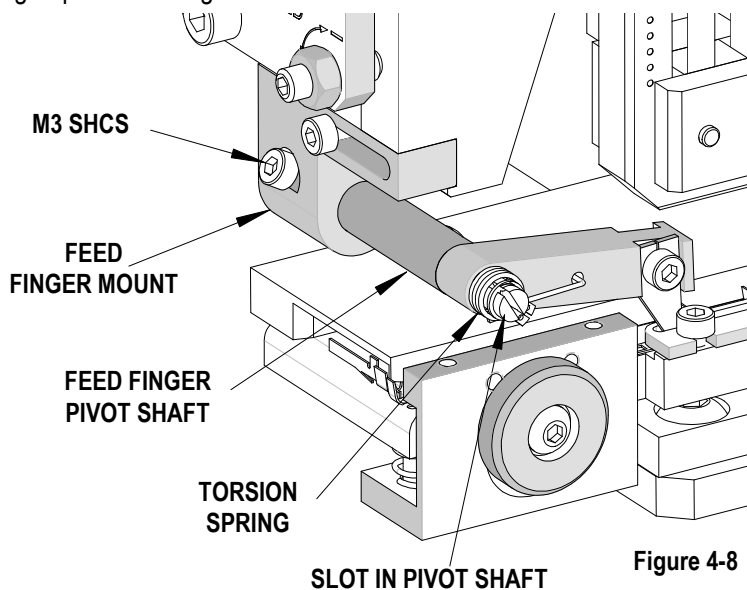

Figure 4-8

#### 4.7 Terminal Forward Feed Adjustment (Centering the Terminal to the Anvils)



**Never operate the Crimp Module if there is a feed problem. Tooling damage can result. Adjust the insulation and conductor adjusting cams to create a loose crimp while solving feed problems. (Move the insulation cam to to the #1 position and turn the conductor adjusting screw CCW until the conductor cam stops.)**

1. The terminal to be crimped must be aligned exactly over the center of the anvils.
2. Disconnect power from the press. Open the guard door.
3. Make sure the press ram is fully up, there is a terminal over the anvils, and the feed finger is fully forward (closest to the anvils).
4. Loosen the FEED LOCK set screw with a 2.5mm hex wrench.
5. Turn the terminal position adjusting knob to center the terminal over the anvils. To move the terminal to the right, turn the FEED knob clockwise. To move the terminal to the left, turn the knob counterclockwise. See Figure 4-9.
6. When adjusting the terminal to the left, it is necessary to pull the terminal strip backwards until it is against the feed finger. When adjusting the terminal to the right, the feed finger will push the terminal farther over the anvils.
7. After properly adjusting the FEED knob, tighten the FEED LOCK set screw.
8. Hand cycle the press to verify proper feed operation.
9. Close the guard door, remove the hand-cycle wrench from the motor, and restore press power

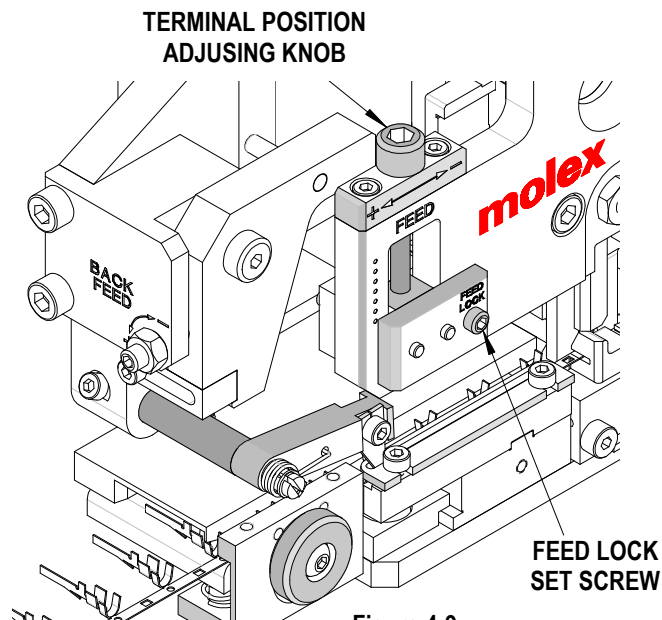

Figure 4-9

#### 4.8 Back Stroke Feed Adjustments (Terminal pitch or spacing on the strip)



**Never operate the Crimp Module if there is a feed problem. Tooling damage can result. Adjust the insulation and conductor adjusting cams to create a loose crimp while solving feed problems. (Move the insulation cam to to the #1 position and turn the conductor adjusting screw CCW until the conductor cam stops.)**

1. Back stroke adjustments are generally not required as it is set once, based on the terminal spacing on the strip.
2. Back stroke adjustments will affect the position of the terminal; re-adjustment of the terminal forward feed position is necessary. See Section 4.7 *Terminal Forward Feed Adjustment*.
3. Since back feed stroke adjustment may not be visibly obvious, the press needs to be hand cycled to observe any feed changes.
4. To properly feed the terminal strip, the back stroke should have enough travel for the feed finger to engage the next carrier hole. Too much or too little travel may cause the feed finger to miss the carrier hole and partially feed the terminal strip.
5. Disconnect the power from the press. Open the guard door.
6. Use an 8mm open-end wrench to loosen the lock nut, then use a 2.5mm hex wrench to turn the BACK FEED set screw. Turning the screw counterclockwise increases the stroke of the back feed; turning it clockwise decreases the stroke.
7. Tighten the lock nut when adjustment is complete. See figure 4-10.
8. Hand cycle the press to verify proper feed operation. It will be necessary to observe the entire feed operation (one complete press cycle) to determine if additional adjustment is needed.

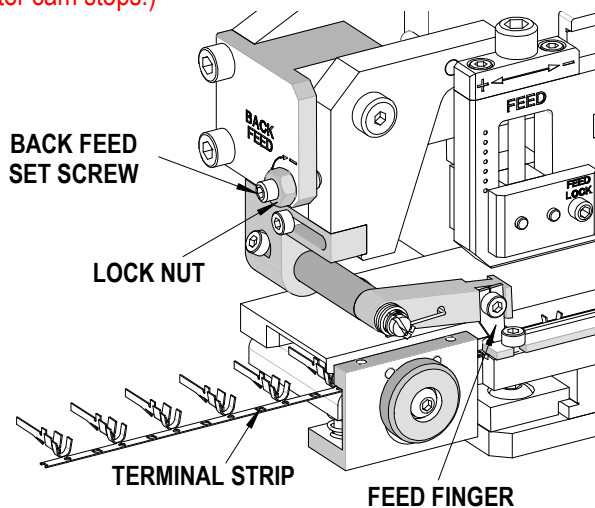

Figure 4-10



9. Make any forward feed adjustments if necessary. See Section 4.7, *Terminal Forward Feed Adjustment*.
10. Close the guard door, remove the hand-cycle wrench from the motor, and restore press power.

#### 4.9 Crimp Tooling Installation and Removal

##### Installation and Removal of the Upper Crimp Tooling (Crimp Punches)



**Always** turn off and disconnect the power supply to the press.

**NOTE:** Always clean mounting surfaces of crimp tooling and tooling holders before installation.



Molex recommends a soft brush; **do not use** compressed air to clean the Crimp Module. The forces created by compressed air can force debris into the tool or at the operator.

1. Disconnect power from the press. Open the guard door.
2. Remove the Crimp Module from the press. See Section 2.3, *Crimp Module Installation and Removal*.
3. Use a 3mm hex wrench to remove the M4 socket head cap screw retaining the ram. See Figure 4-11.

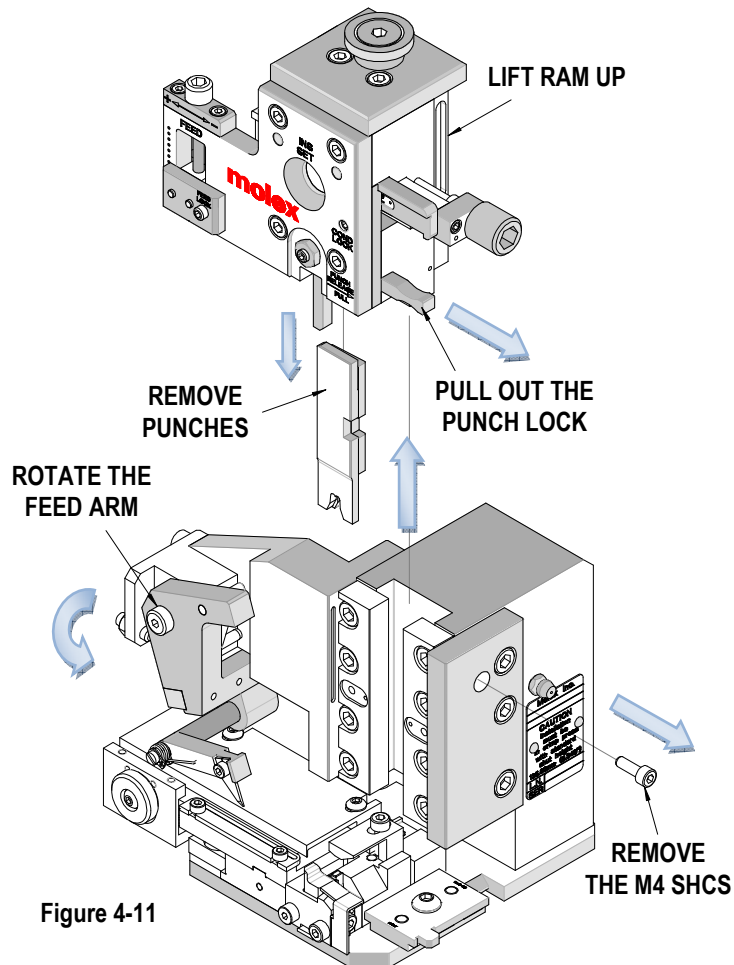

4. Rotate the feed arm and remove the ram from the applicator.
5. Pull out the punch release. While holding it out, pull the conductor and insulation crimp punches out the bottom of the ram. See Figure 4-11.
6. Reverse the previous steps to reinstall the punches. Refer to the Application Tooling Specification for orientation and placement of crimp punches and any other upper tooling.

## Installation and Removal of the Lower Crimp Tooling (Crimp Anvils)



**Always** turn off and disconnect the power supply to the press.

1. The lower tooling must be aligned (by hand-cycling the press) when tooling is replaced.
2. Disconnect power from the press. Open the guard door.
3. Remove the M6 button head cap screw holding the right locating plate. Remove the locating plate.
4. On the T2 tool sets, remove the M4 socket head cap screws that hold the lower tooling in place and pull out the tooling. See Figure 4-12.
5. On the Terminator tool sets, remove the #10 socket head cap screw and pull out the tooling.
6. When installing the new anvils, leaving the mounting screws loose for alignment to the crimp punches. Refer to the Application Tooling Specification sheet for proper installation sequence of lower tooling. See also Section 2.6 and 2.7, *Punch and Anvil Alignment*.

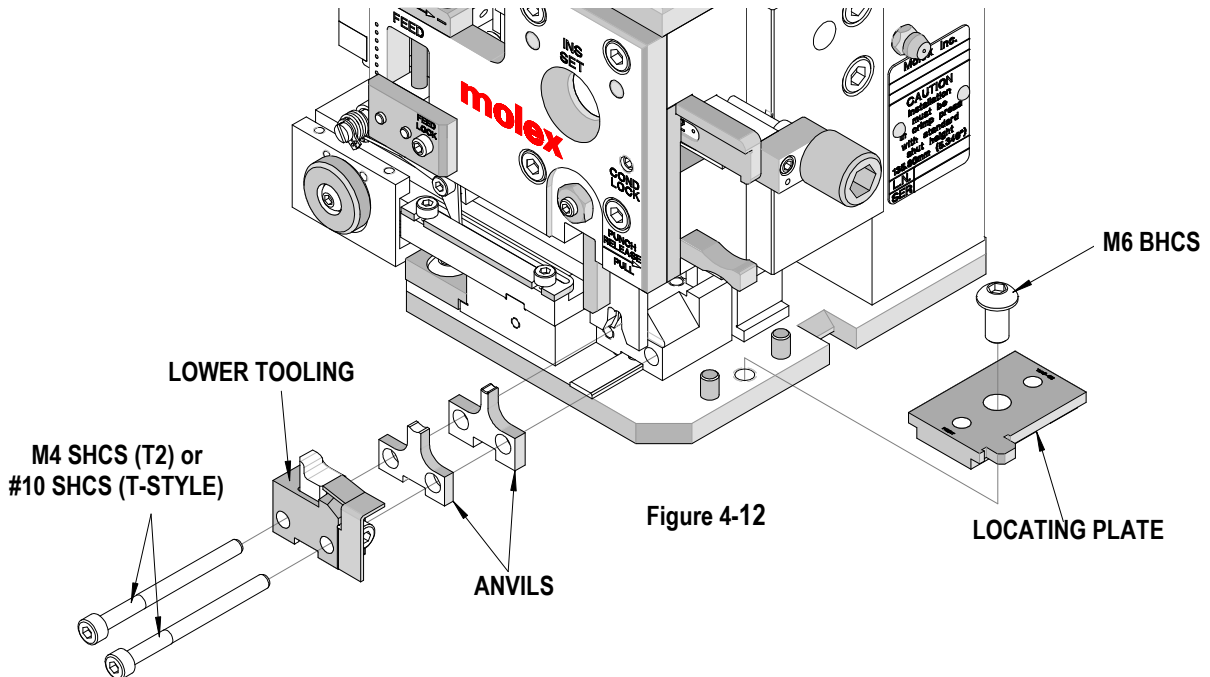

## Section 5

### Maintenance

#### 5.1 Cleaning



**Always** turn off and disconnect the power supply to the press.

 For efficient operation, the Crimp Module should be cleaned daily. Use a soft bristle brush to remove debris from critical areas such as the crimp tooling. For best results, remove the crimp tooling from the press. Brush and then use a clean cloth to wipe off the upper and lower tooling mounting areas. Before reinstalling tooling, wipe all sides of the punches and anvils with a clean cloth.

#### 5.2 Lubrication



**Always** turn off and disconnect the power supply to the press.



1. Make sure the press ram is fully up.
2. Disconnect power from the press. Open the guard door.
3. Use a grease gun on the Zerk fitting to grease the ram guides.
4. Oil the feed finger pivot and feed arm pivot.

For the ram, use synthetic grease with Teflon® or an equivalent. (The Crimp Module is shipped greased with Permatex® No. 82329.) An SAE30W non-detergent oil or light machine oil should be used on pivot points.



**WARNING: Never use penetrants such as WD40 for any lubrication on the Crimp Module.**

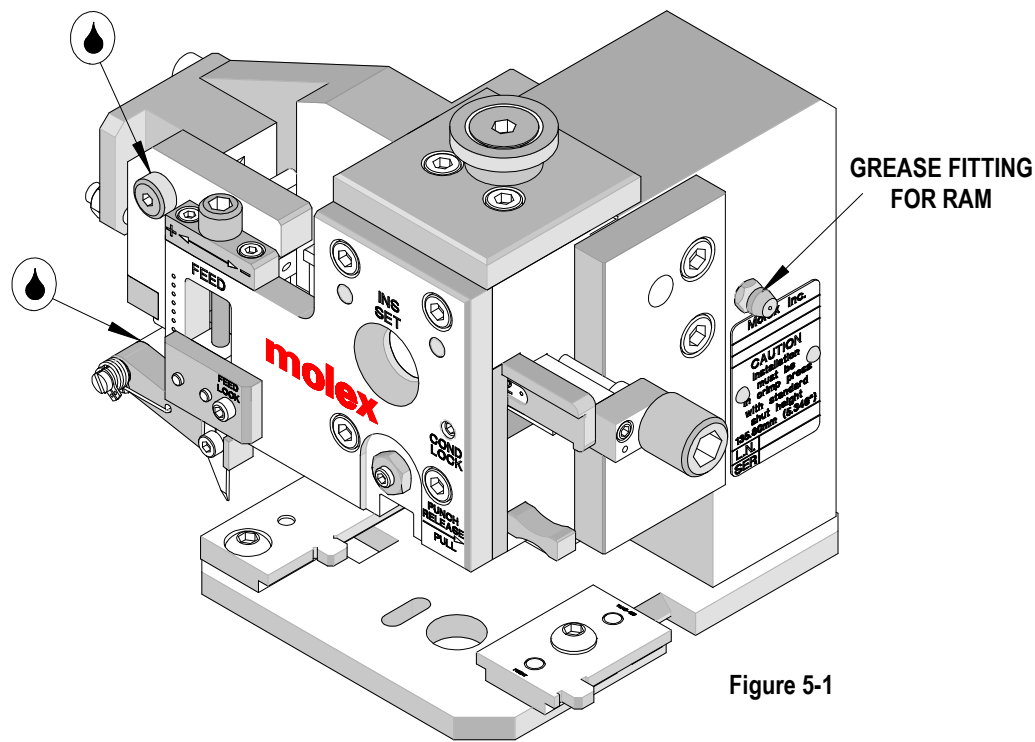

Figure 5-1

### Preventive Maintenance Chart

An example of a maintenance chart is shown below. Use this chart to track the maintenance of your Crimp Module or use it as a template to create a schedule.

**Daily:** Clean. See Section 5.1.

**As Required:** Lubricate. See Section 5.2.

CHECK SHEET MONTH \_\_\_\_\_ YEAR \_\_\_\_\_

Week	Cycles	Daily Clean	Days of the Week							Notes
			MON	TUE	WED	THU	FRI	SAT	SUN	
1										
2										
3										
4										
Cleaning Reapply grease Reapply oil	25,000	Yes								Soft Brush Industrial Degreaser
Inspect all tooling (feed fingers, etc.) for wear	25,000	Yes								Replace if worn

Schedule should be adjusted up or down depending on usage. Molex recommends that a log of preventive maintenance be kept with the press.

#### 5.3 Spare Parts

Customers are responsible for maintaining the Crimp Module. Spare parts are available. Moving and functioning parts can be damaged or wear out over time and will require replacement. Having some spare parts on-hand will reduce production down time.

Recommended Spare Parts are noted as RSP in the Crimp Module parts list.

#### 5.4 Perishable Parts



Perishable parts come in contact with the terminal or wire and tend to wear quickly or are fragile. At least one perishable tool kit should be on-hand to reduce production down time. **For the proper perishable tool kit information, refer to the Application Tooling Specification sheet supplied with the tooling.**



### Tooling Replacement Schedule

The following is offered as a general guideline for tooling replacement. The user should monitor their process and collect data on actual frequency as tool wear varies on different terminal materials and tool life can be increased with good maintenance practices or decrease with lack of maintenance.

Judgment on tool replacement should be based on the attributes of the crimp they produce.

See the following chart for common signs of wear.

<b>Punches</b>	<b>On Terminal</b>	<b>Notes</b>
Scoring	Uneven Curls	Replace
	Terminal Sticking	Replace
Tip Loss	Open seam	Replace
<b>Anvils</b>		
Rounded Edges	Large Extrusion	Replace
Chipping	Burrs-On Tabs	Replace
Worn Cut Edges	Burrs	Replace
<b>Cut-Off Plungers and Punches</b>		
Chipped or Rounded	Burr on Tab	Replace
Cut Edge	Burr on Tab	Replace
Cut-off Dies	Burrs on Cut Area	Replace

### 5.5 Crimp Module Storage

To prevent damage to the crimp punches and anvils leave a strip of terminals in the Crimp Module.

## Section 6

## 6.1 Main Parts List

T2 and Terminator Crimp Module					
Item No.	Order No.	Engineering No.	Description	RSP Parts	Qty
<b>Perishable Tooling</b>					
1	69001-0105	69001-0105	Feed Finger-Straight		1
<b>Other Components</b>					
2	11-19-3101	7179-1A	Insulation Crimp Adjusting Slide		1
3	11-19-3107	7179-7A	Conductor Crimp Adjuster		1
4	11-32-5346	60000Y422	Metric Ball Plunger		1
5	11-40-0218	TM40-100	Locating Plate		1
6	63600-4040	63600-4040	M6Grease Fitting		1
7	63600-4042	63600-4042	Compression Spring	RSP	1
8	63600-4043	63600-4043	Adjusting Screw		1
9	63600-4044	63600-4044	Extension Spring	RSP	1
10	63600-4536	63600-4536	M4 Adjusting Bolt		1
11	63801-6447	63801-6447	Ram Adapter		1
12	63801-8501	63801-8501	Frame		1
13	63801-8502	63801-8502	Y-Gib		2
14	63801-8503	63801-8503	X-Gib		1
15	63801-8504	63801-8504	Feed Mount		2
16	63801-8510	63801-8510	Ram		2
17	63801-8511	63801-8511	Face Plate		2
18	63801-8512	63801-8512	Top		1
19	63801-8513	63801-8513	Y-Cap		1
20	63801-8514	63801-8514	Cam Cover		1
21	63801-8515	63801-8515	Feed Adjust Cap		1
22	63801-8516	63801-8516	Feed Adjust Clamp		1
23	63801-8517	63801-8517	Feed Pin Block		1
24	63801-8518	63801-8518	Punch Lock		1
25	63801-8519	63801-8519	Feed Adjust Block		1
26	63801-8520	63801-8520	Adjusting Screw Retainer		1
27	63801-8521	63801-8521	Pilot Pin Keeper		1
28	63801-8530	63801-8530	Feed Arm Mount		1
29	63801-8531	63801-8531	Feed Lever		1
30	63801-8532	63801-8532	Feed Lever Y Adjustment		1
31	63801-8533	63801-8533	Feed Arm Shaft		1
32	63801-8540	63801-8540	Base Plate		1
33	63801-8541	63801-8541	Guide Block		1
34	63890-0999	63890-0999	Serial Number Plate		1
35	69002-5526	69002-5526	Feed Arm		1
36	69002-5527	69002-5527	Feed Arm Spring	RSP	1
<b>Hardware</b>					
37	698100400	N/A	#2 by 1/8 long Drive Screw		2**
38	699010203	N/A	Retaining Ring		2**
39	699011305	N/A	M3 by 5 long SHCS		2**
40	699011308	N/A	M3 by 8 long SHCS		2**
41	699011316	N/A	M3 by 16 long SHCS		1**
42	699011320	N/A	M3 by 20 long SHCS		2**
43	699011412	N/A	M4 by 12 long SHCS		3**
44	699011512	N/A	M5 by 12 long SHCS		8**

T2 and Terminator Crimp Module					
Item No.	Order No.	Engineering No.	Description	RSP Parts	Qty
45	699011608	N/A	M6 by 8 long SHCS		1**
46	699011612	N/A	M6 by 12 long SHCS		18**
47	699021610	N/A	M6 by 10 long BHCS		2**
48	699021612	N/A	M6 by 12 long BHCS		5**
49	699031830	N/A	M8 by 30 long FHCS		2**
50	637003270	N/A	#4-40 by .38 long SHCS		2**
51	699041508	N/A	M5 by 8 long Set Screw		1**
52	699041516	N/A	M5 by 16 long Set Screw		1**
53	699056510	N/A	M6 by 10 long SHSS		1**
54	637002929	N/A	#10-32 by 5/8 long Set Screw(Flat Point)		1**
55	699071500	N/A	M5 Hex Nut		1**
56	637003201	N/A	#10-32UNF Hex Jam Nut		1**
57	698091308	N/A	3mm by 8 long Dowel		1**
58	698091412	N/A	4mm by 12 long Dowel		4**
59	698091416	N/A	4mm by 16 long Dowel		1**
60	698091420	N/A	4mm by 20 long Dowel		2**
61	698091516	N/A	5mm by 16 long Dowel		2**
62	637004924	N/A	#1/16 by 3/8 long Dowel Pin		1**
63	699105068	N/A	#3/16 by 1/2 long Dowel		2**
RSP - Part is a Molex Recommended Spare Part.					
* Available from an industrial supply company such as MSC (1-800-645-7270).					

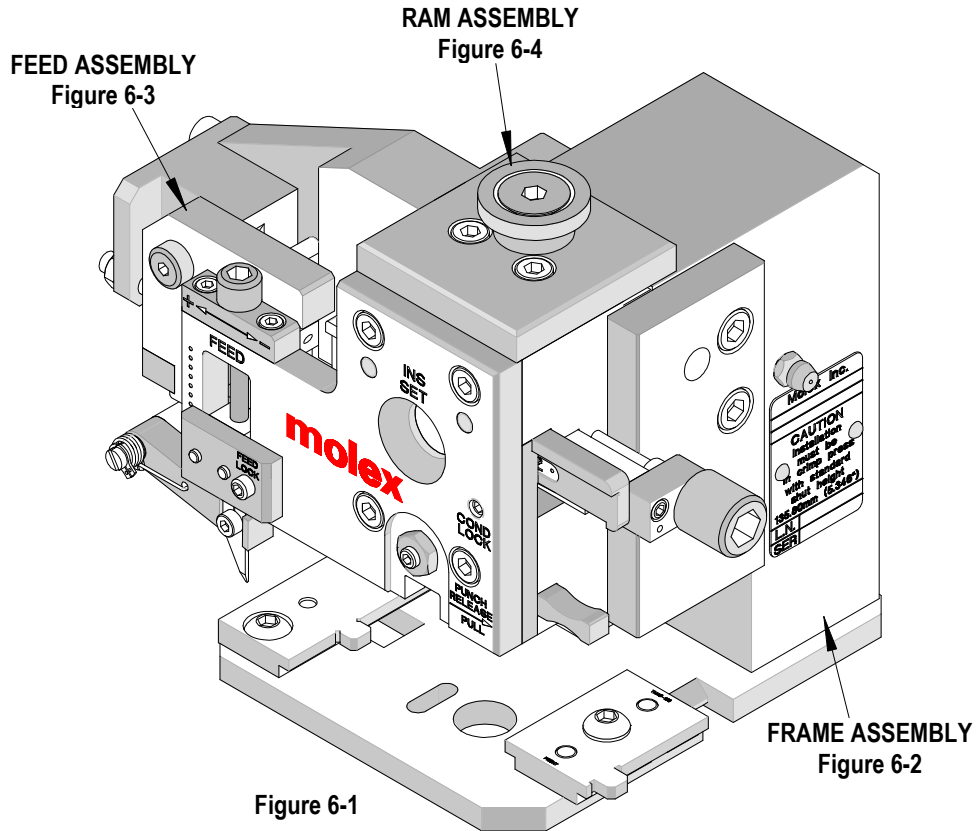

### 6.2 Frame Assembly

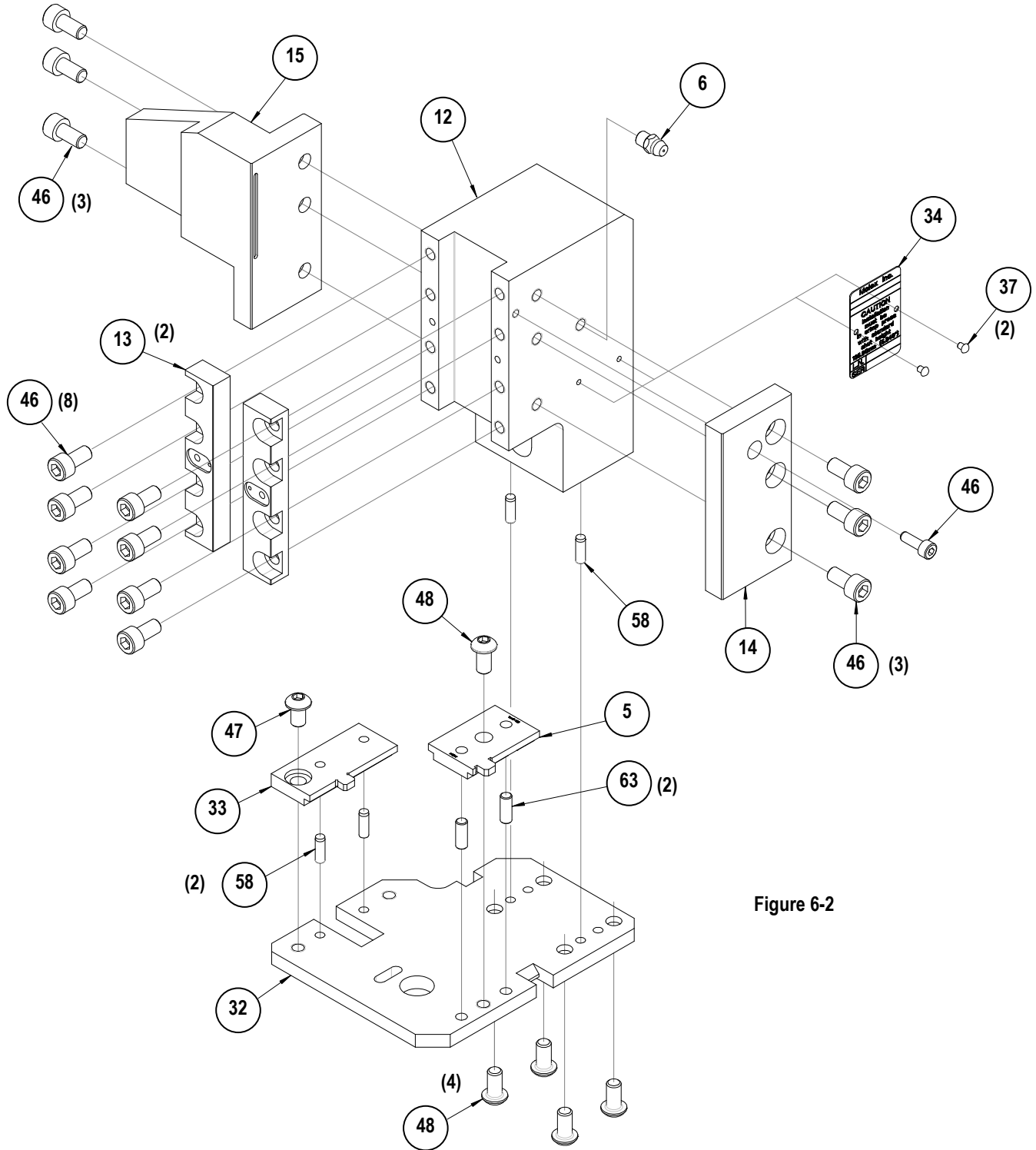

Figure 6-2

### 6.2 Feed Assembly

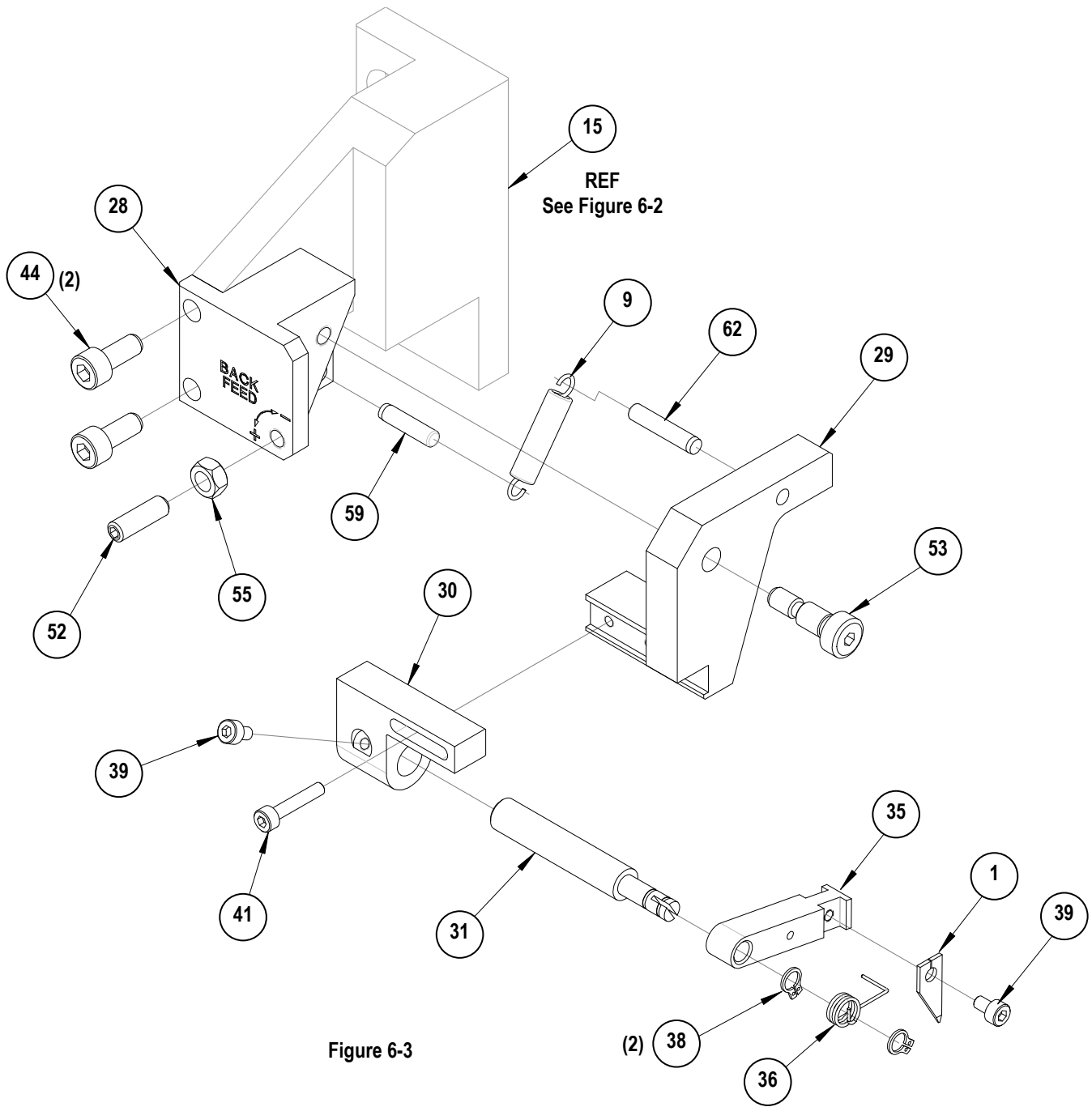

Figure 6-3

### 6.2 Ram Assembly

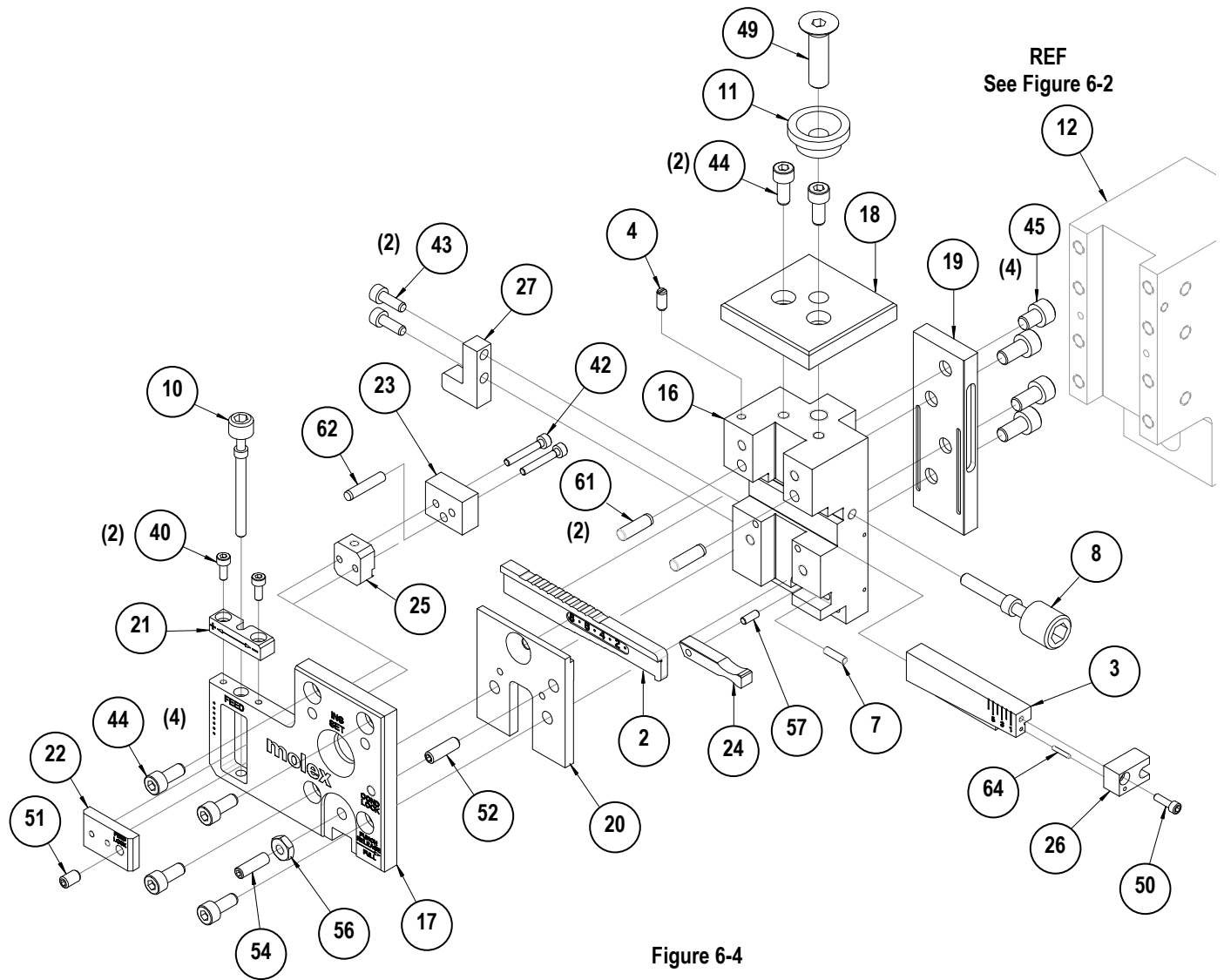

Figure 6-4

### 6.3 Terminator Set-up

#### Typical T2 Tool Set – Front Carrier (Figure 6-5)

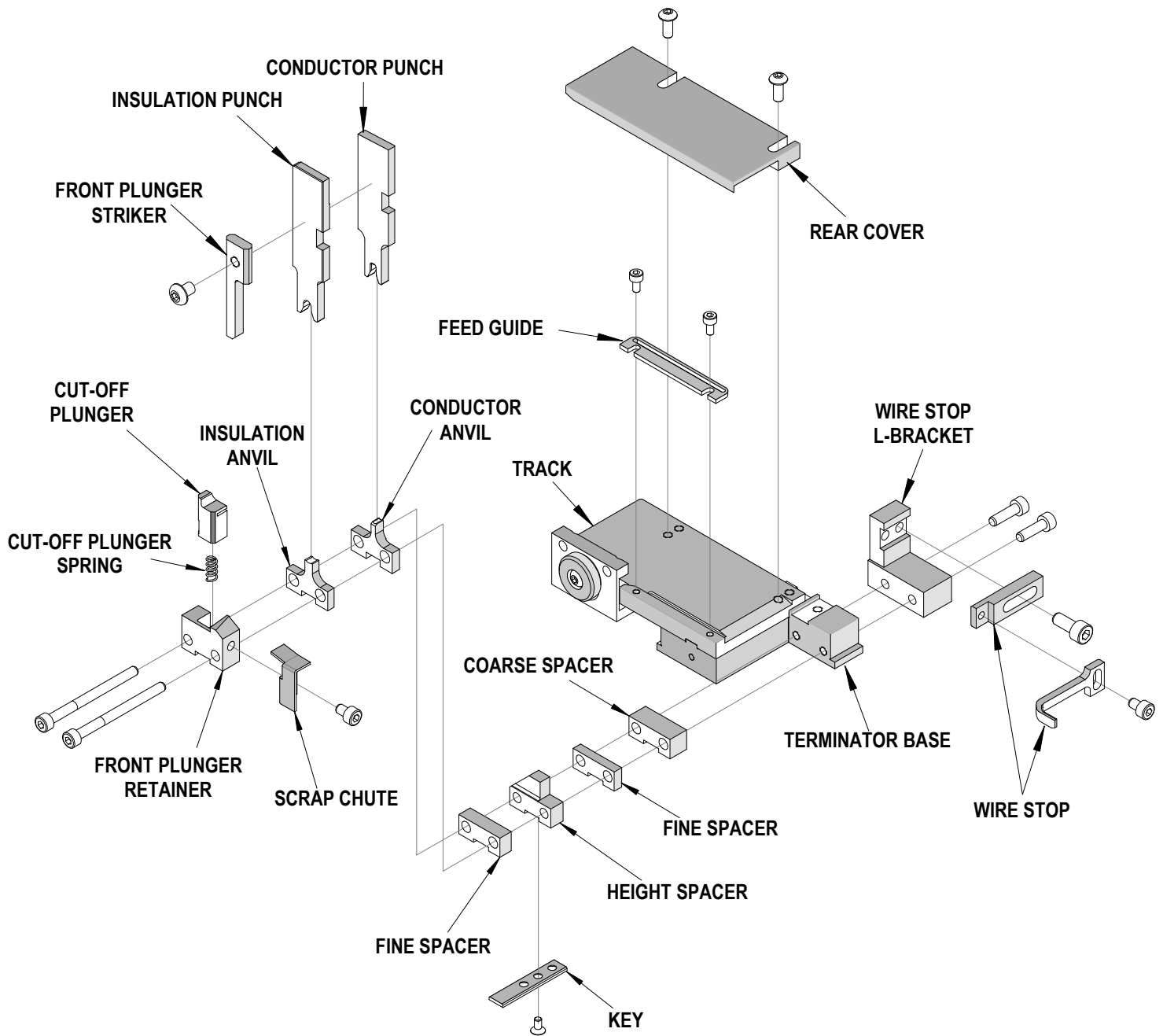

Figure 6-5

Typical T2 Tool Set – Dual Carrier (Figure 6-6)

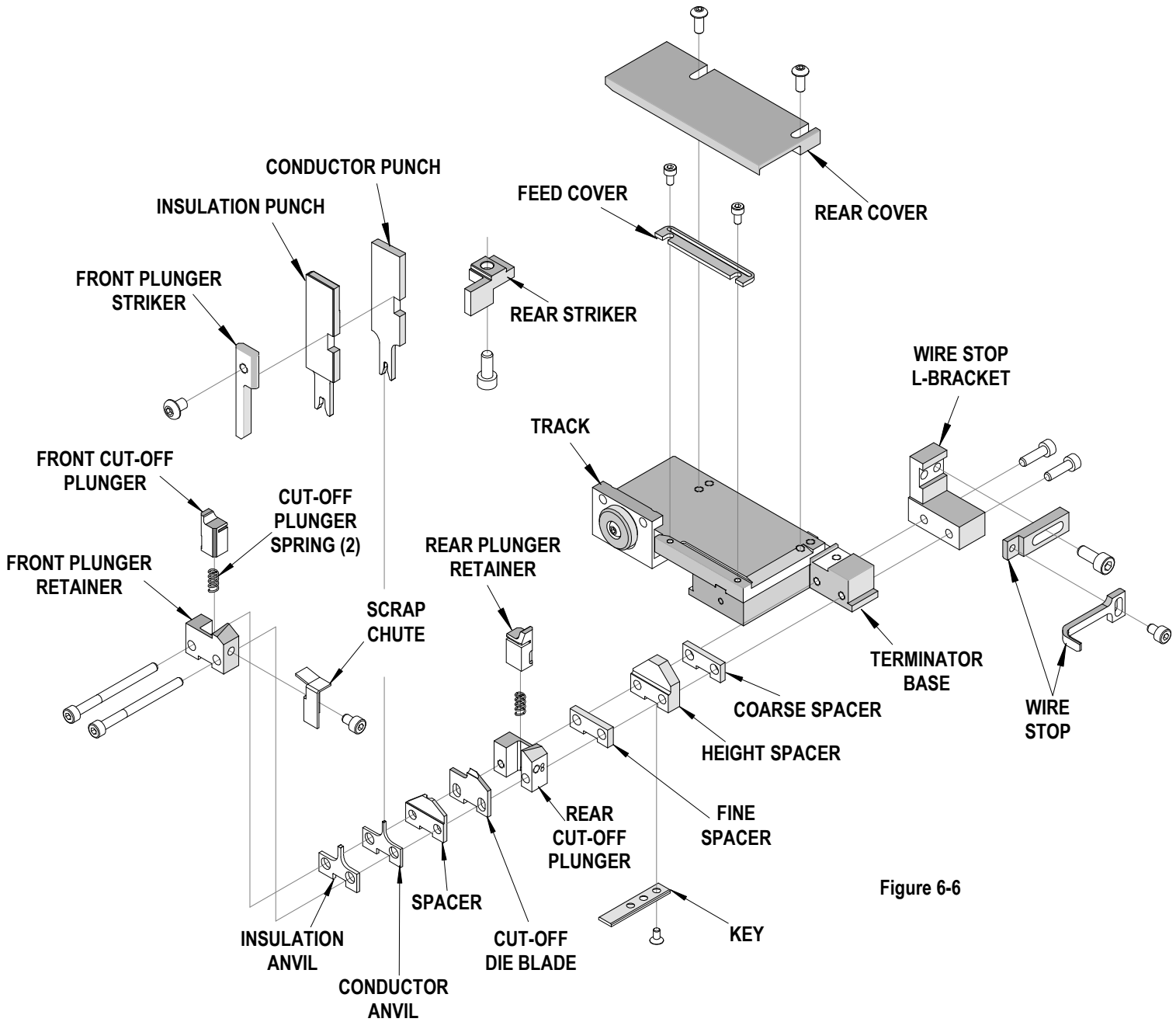

Figure 6-6



Typical T2 Tool Set – Rear Carrier (Figure 6-7)

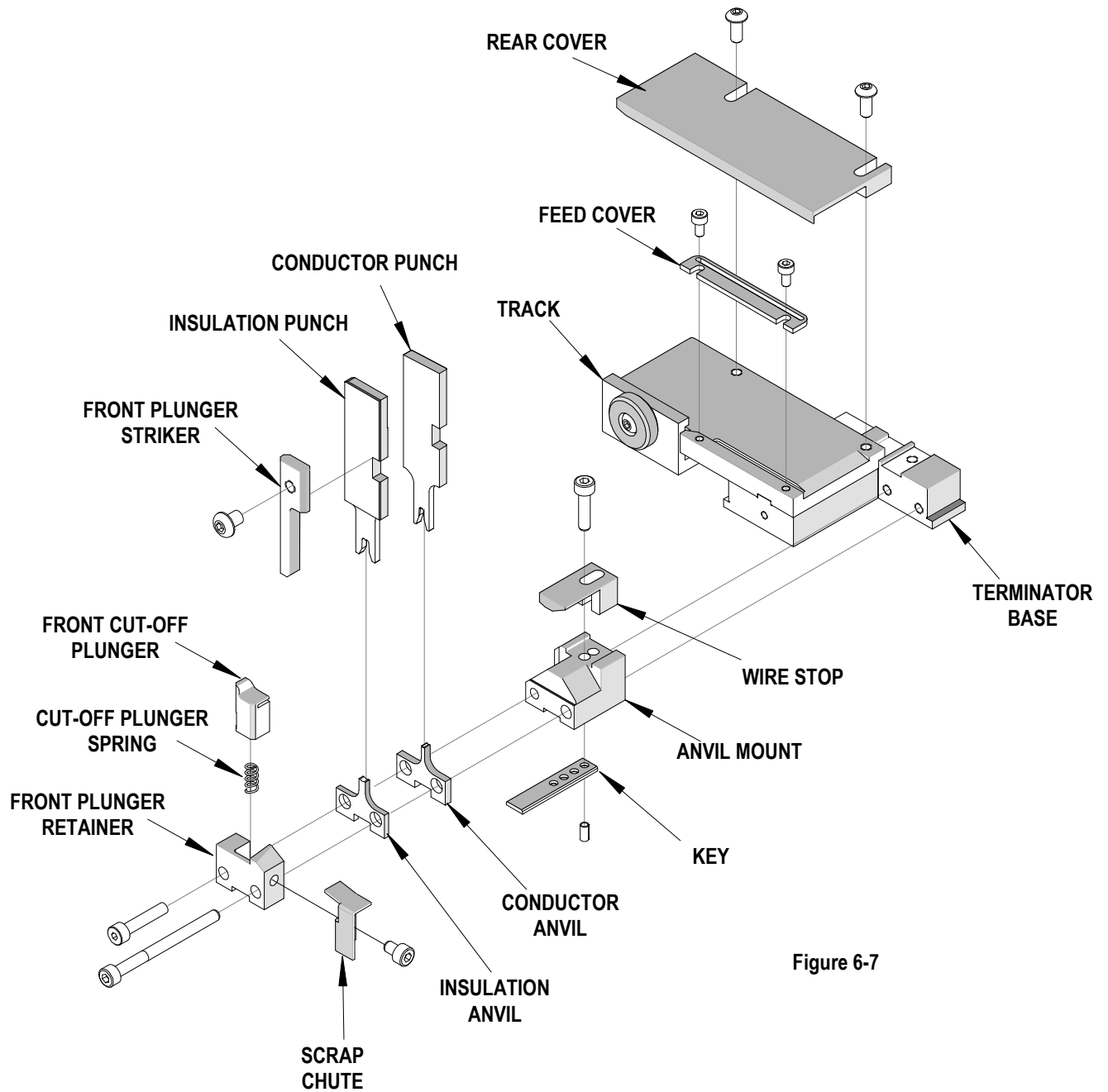

Figure 6-7

Typical Terminator Tool Set – Front Carrier (Figure 6-8)

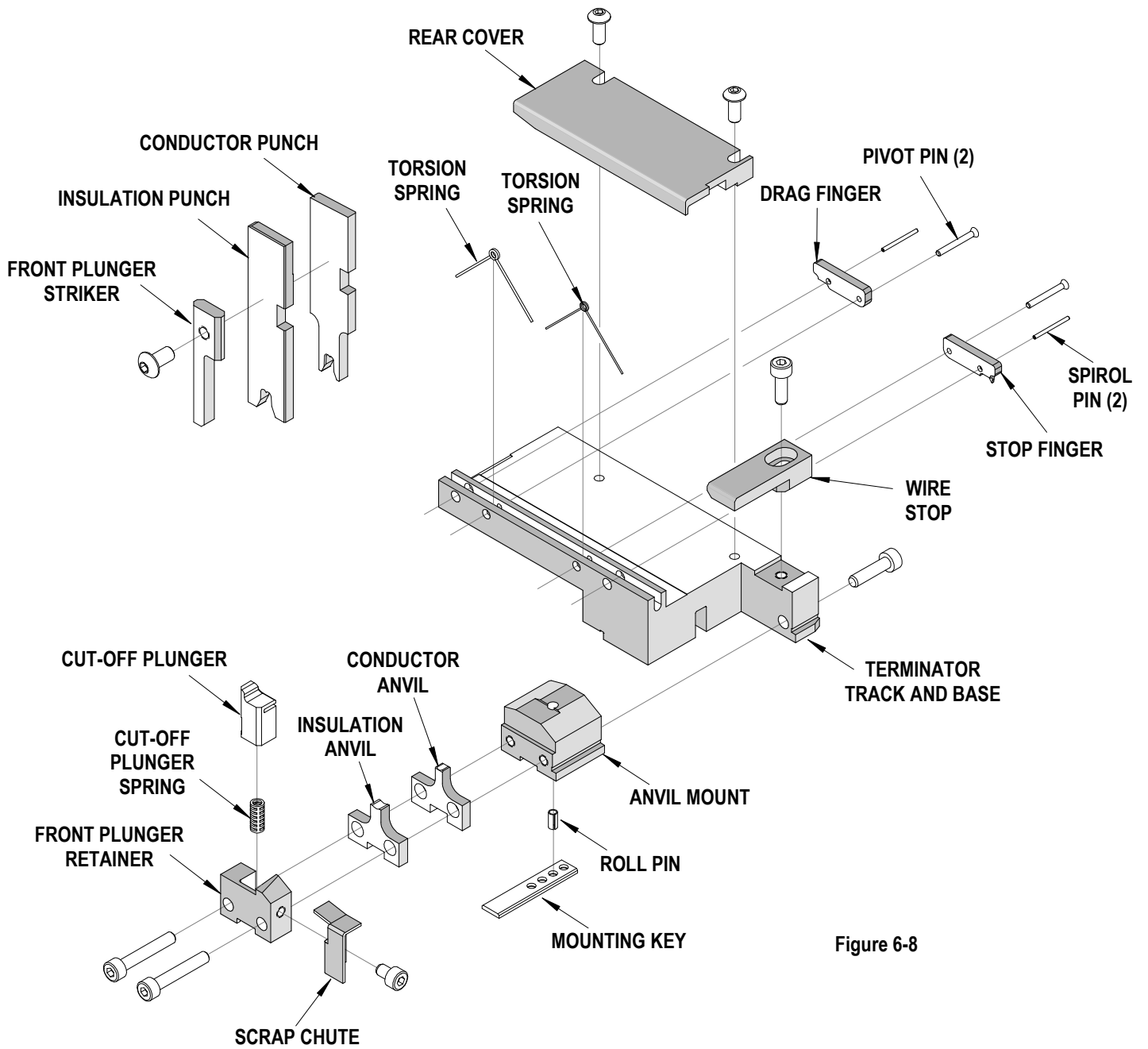

Figure 6-8

Typical Terminator Tool Set – Rear Carrier (Figure 6-9)

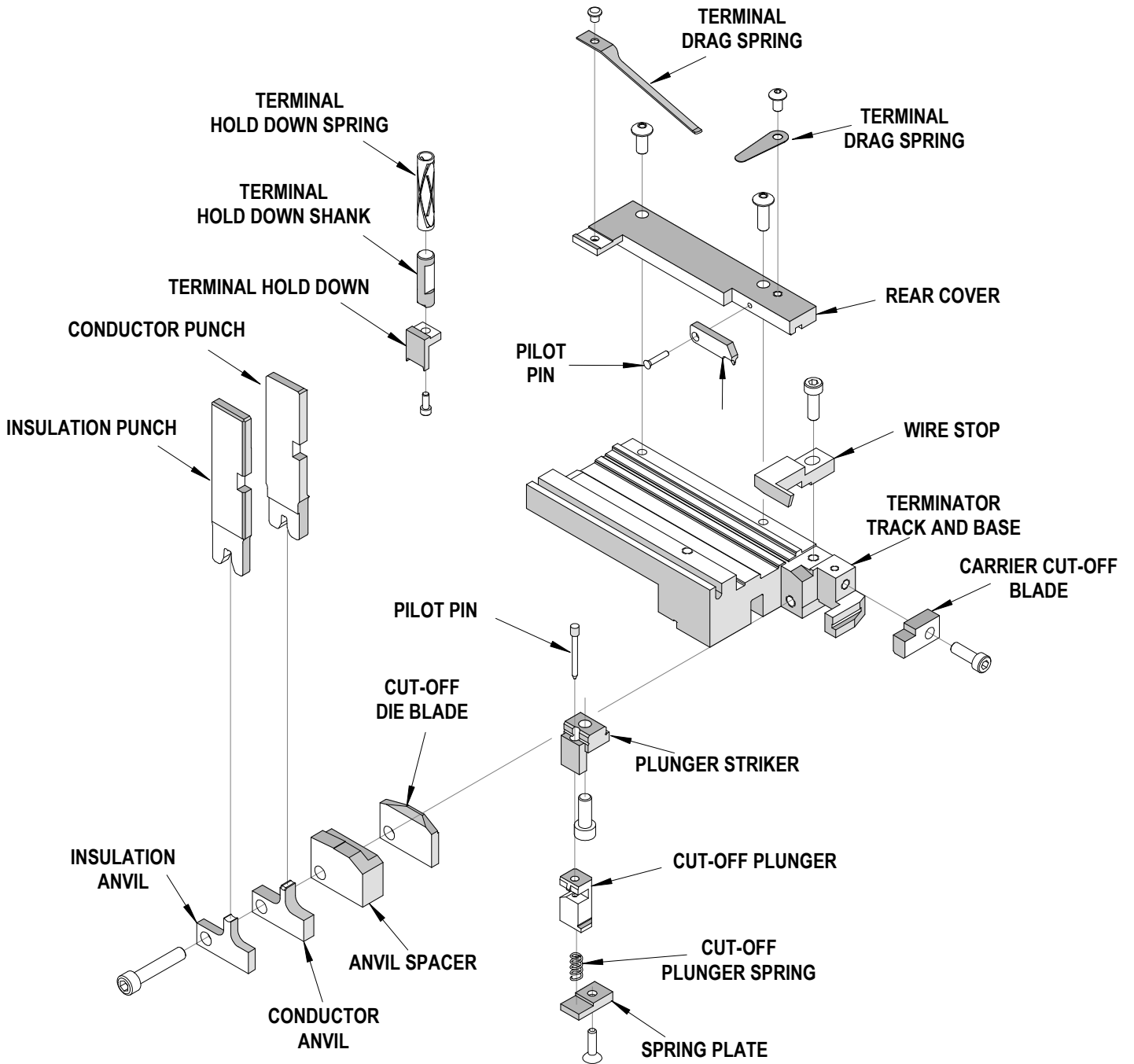

Figure 6-9

Typical Terminator Tool Set – Dual Carrier (Figure 6-10)

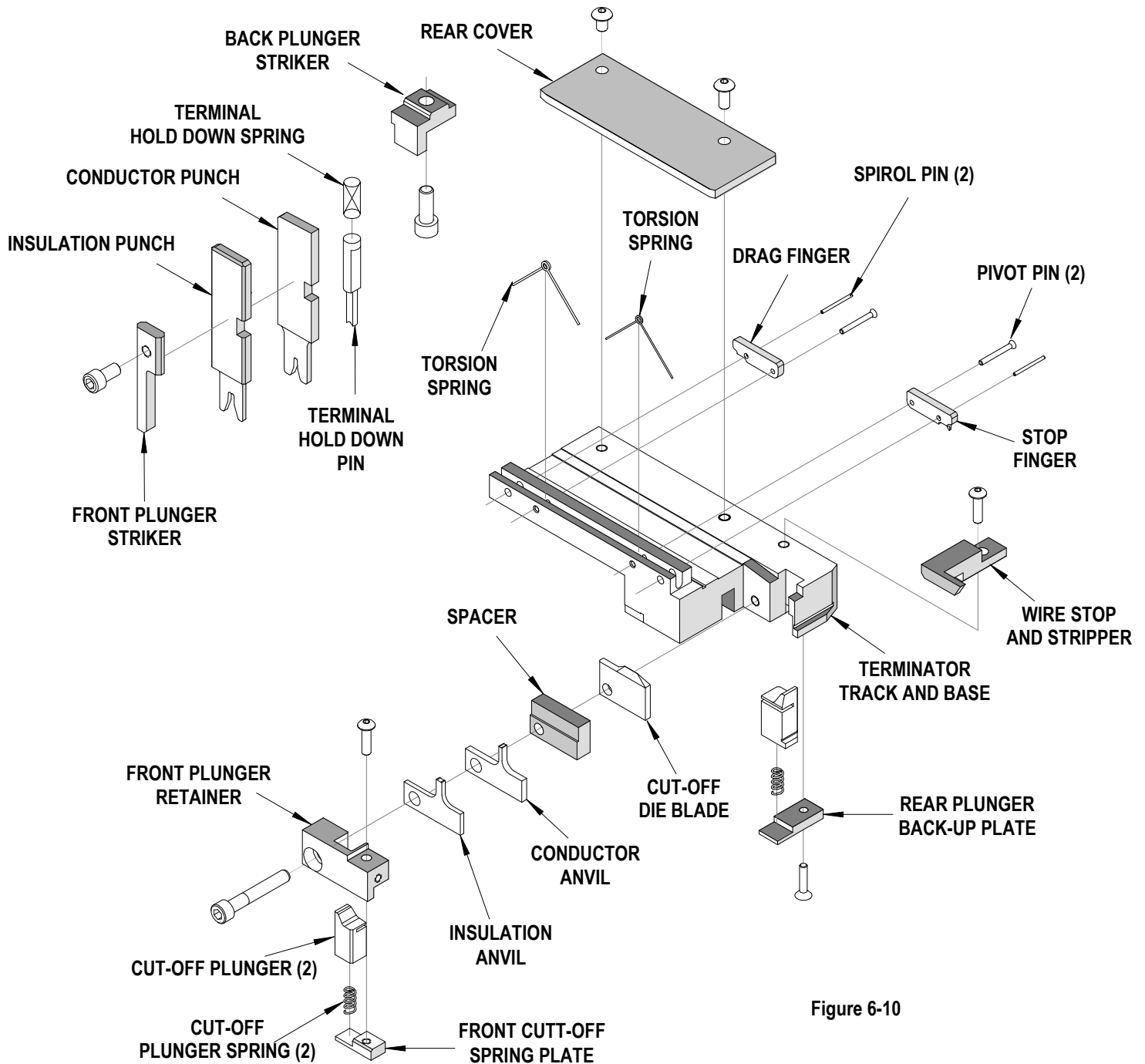

Figure 6-10

Typical Terminator Tool Set – Center Carrier (Figure 6- 11)

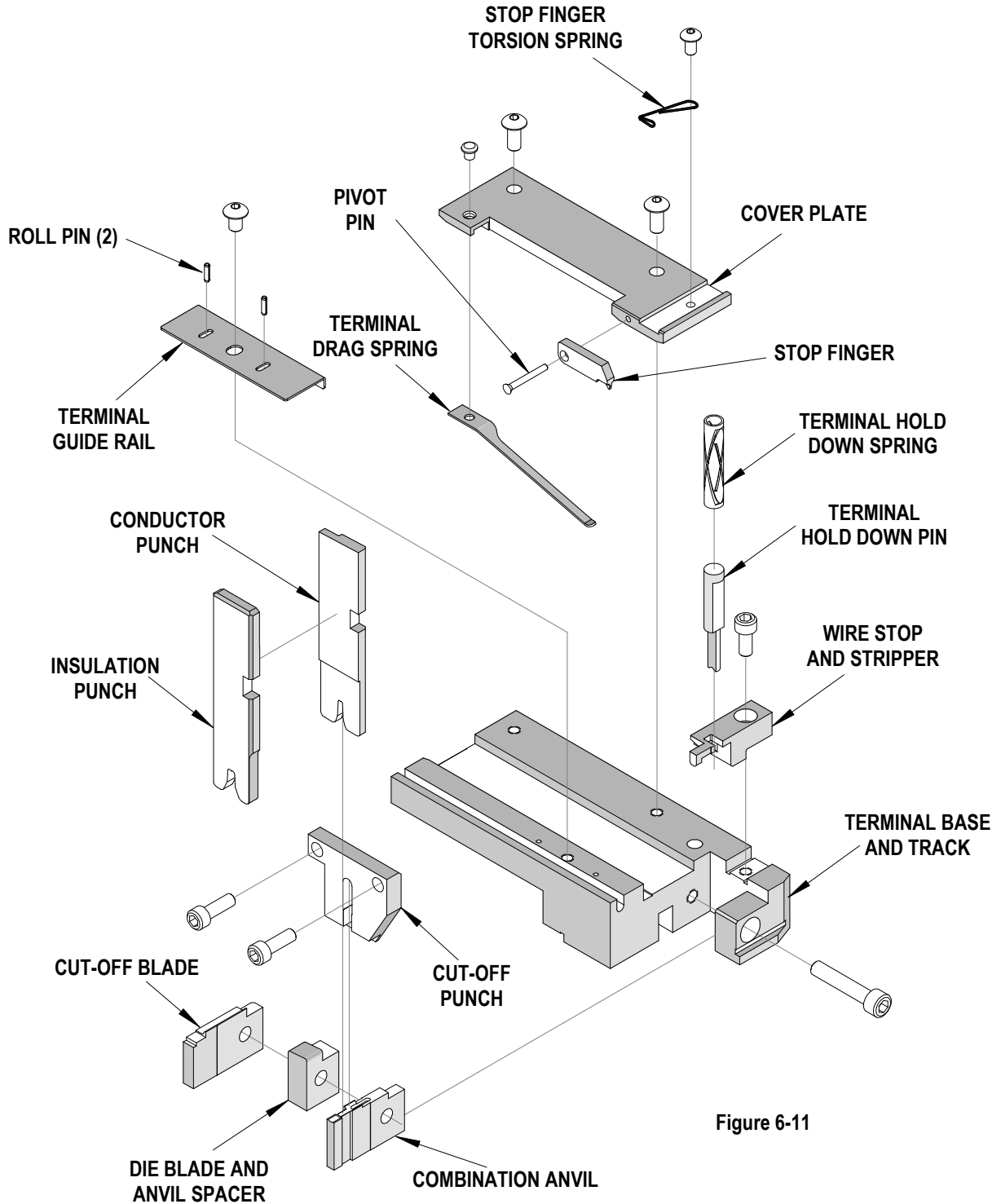

Figure 6-11

“T” Micro Terminal (Figure 6-12)

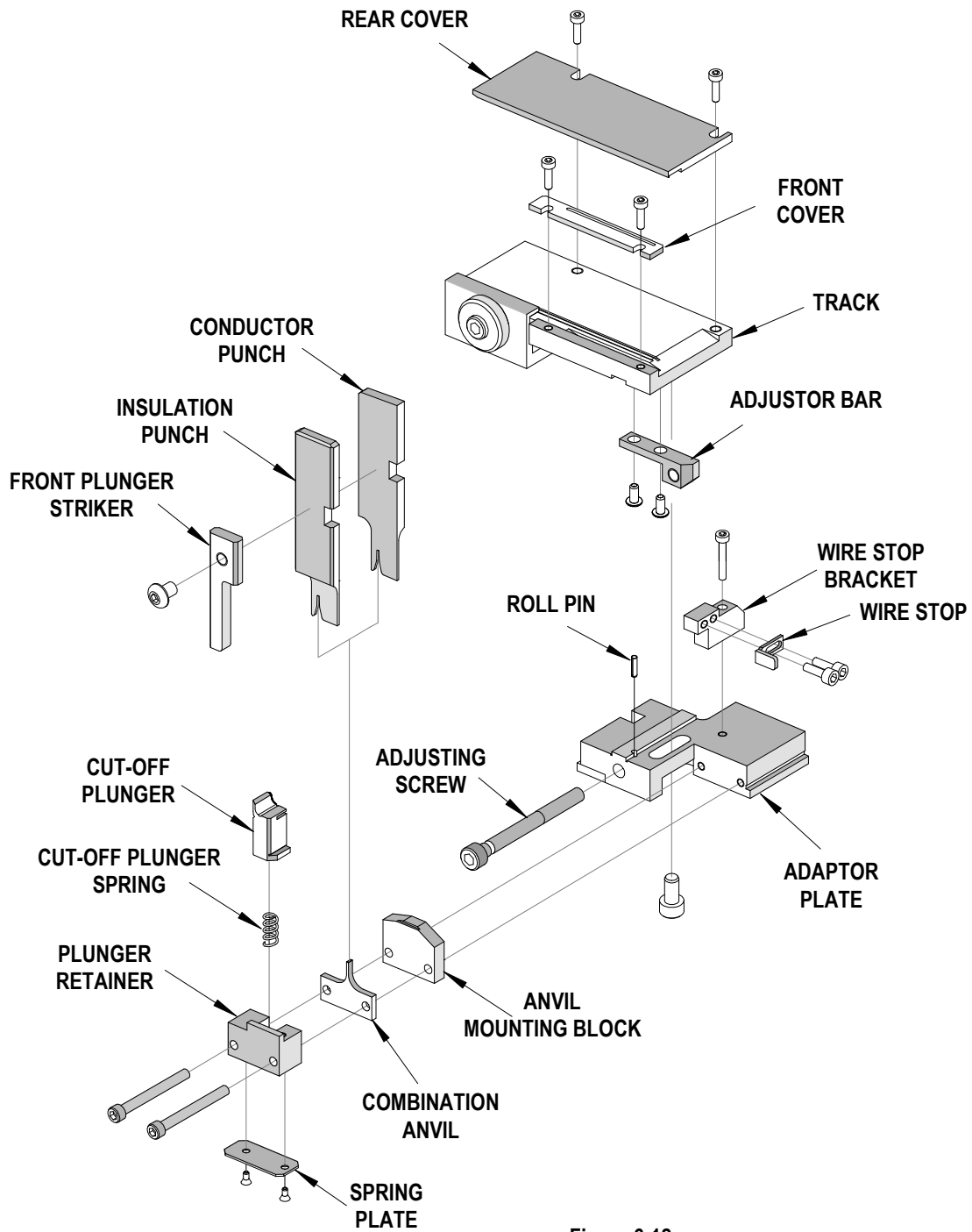
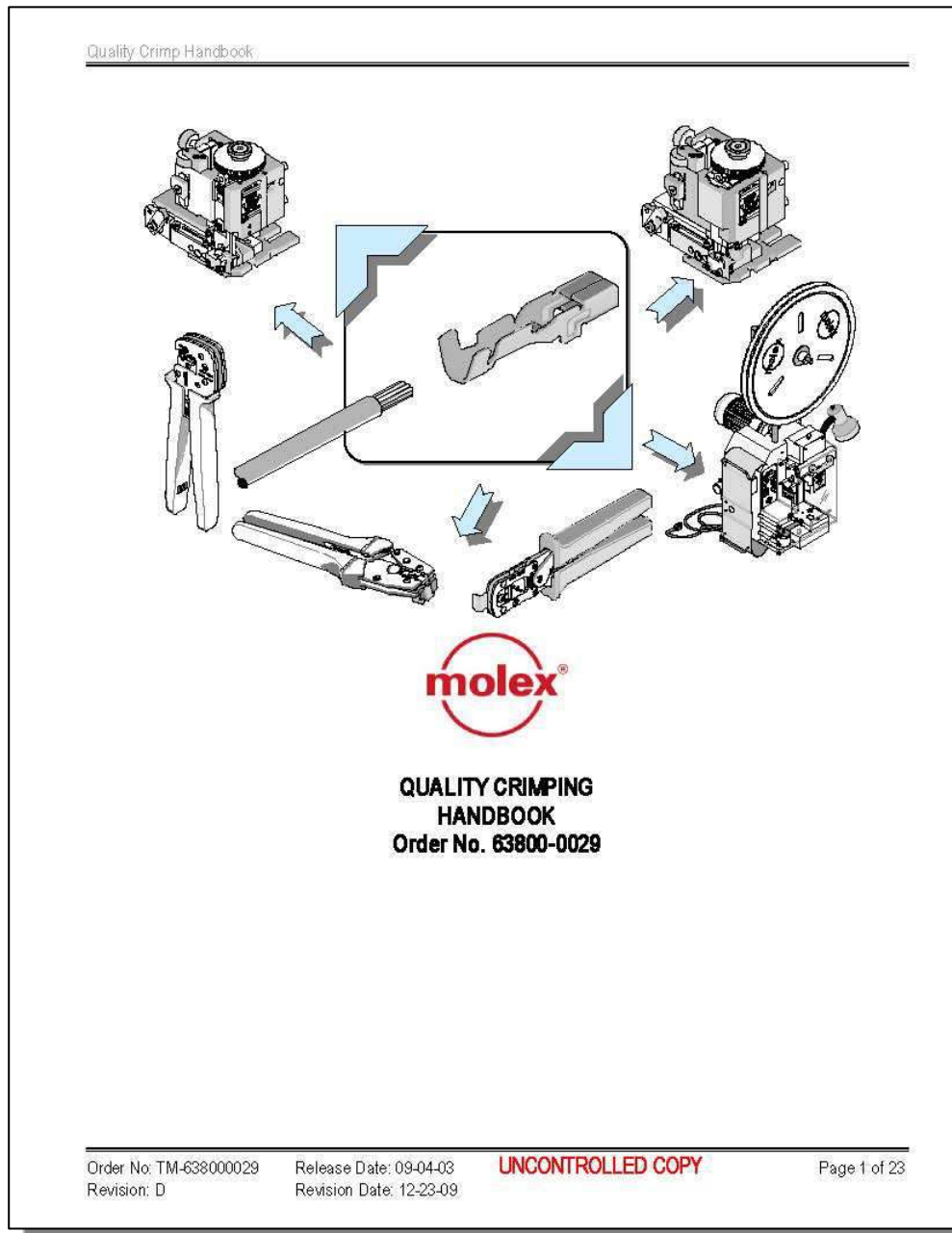

Figure 6-12

For more information see the Molex Quality Crimping Handbook (63800-0029)

Available on the Molex website ([www.molex.com](http://www.molex.com)) or contact your local Molex sales engineer



Visit our Web site at <http://www.molex.com>