

6

5

4

3

2

1

FACE VIEW-FEMALE INSERT

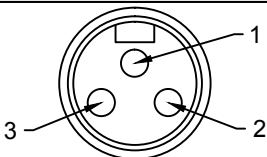

1 GREEN
2 BLACK
3 WHITE

MATERIAL P/N #	ENGINEERING P/N	FINISHED LENGTH
1300062113	50919	10' +6.5"-0 (3.0M +165.1mm-0)
1300062101	40943	12' +6.5"-0 (3.7M +165.1mm-0)
1300180192	61902	18' +12.5"-0 (5.5M +317.5mm-0)
1300062114	50972	30' +24.5"-0 (9.1M +622.3mm-0)

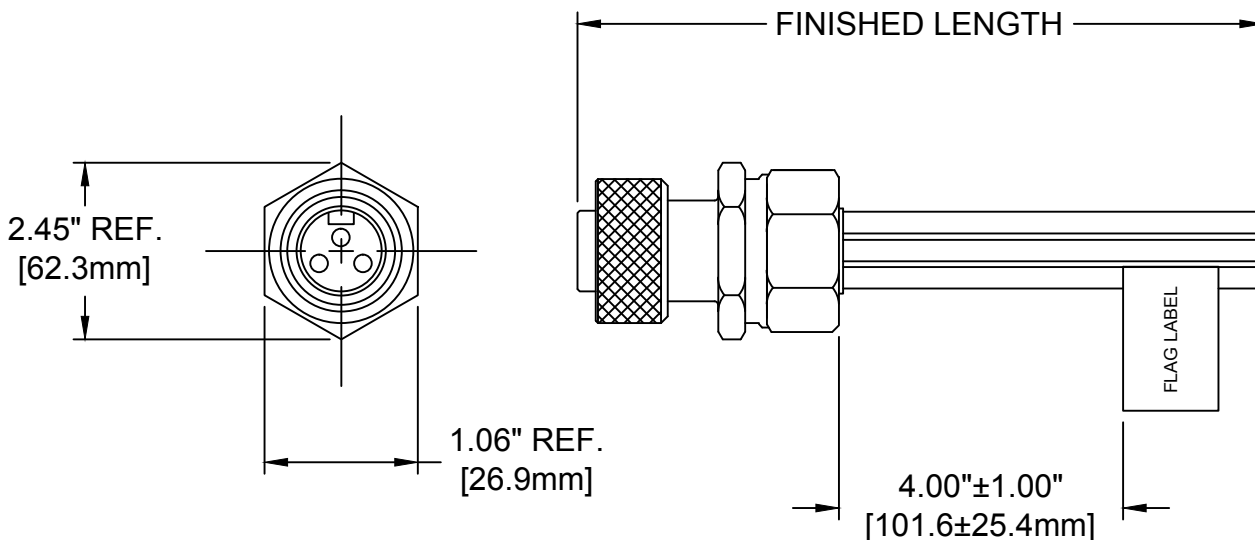

SPECIFICATIONS:

MINI-CHANGE RECEPTACLE:

RECEPTACLE SHELL: ZINC PLATED STEEL
 CONTACT: GOLD/NICKEL OVER COPPER ALLOY
 INSERT: YELLOW PVC
 CLAMP NUT: ZINC PLATED STEEL
 PLASTIC FERRULE: WHITE NYLON
 METAL FERRULE: ZINC PLATED STEEL
 LABEL: YELLOW VINYL

WIRE: #16/1 THERMOPLASTIC 1015/TEW WIRE
 WIRE MARKING: STYLE 1015, MTW AND CSA
 TEW, 16AWG, 600V AND 105°C
 ASSEMBLY RATINGS: 600V Max., 13A Max.
 PROTECTION CLASS: IP67

INITIAL RELEASE EC NO: IPG2014-1419 DRWN: BARDEN 2014/02/07 CHKD: TWOLDEGE APPR: BWOODMAN 2014/02/11	QUALITY SYMBOLS ▽=0 ▽C=0	GENERAL TOLERANCES (UNLESS SPECIFIED)		DIMENSION STYLE IN/MM		SCALE NTS	DESIGN UNITS INCH	THIRD ANGLE PROJECTION	
			mm	INCH	DRAWN BY BARDEN	DATE 2014/02/07	TITLE MC 3P FP LIQUID TIGHT 16AWG PVC		
		4 PLACES	±---	±---	CHECKED BY TWOLDEGE	DATE 2014/02/11	MOLEX INCORPORATED		
		3 PLACES	±---	±.005	APPROVED BY BWOODMAN	DATE 2014/02/11			
			ANGULAR ±1/2°		MATERIAL NO.	DOCUMENT NO. SD-130062-018	SHEET NO. 1 OF 1		
A	REV	DRAFT WHERE APPLICABLE MUST REMAIN WITHIN DIMENSIONS		SEE CHART		THIS DRAWING CONTAINS INFORMATION THAT IS PROPRIETARY TO MOLEX INCORPORATED AND SHOULD NOT BE USED WITHOUT WRITTEN PERMISSION			

6

5

4

3

2

1