

Adjustable Offline Inductorless Switching Regulators

Features

- Efficient Operation without Magnetics
- No High-voltage Capacitors
- Adjustable Main Output Voltage (9V to 50V)
- Additional Internal Linear Regulator:
 - 3.3V for SR086
 - 5V for SR087
- Up to 100 mA Combined Output Current
- Single BOM for 120 VAC/230 VAC
- Built-in Soft Start
- Less than 200 mW Standby Power

Applications

- White Goods
- Household Appliances
- Lighting Controls
- Circuit Breakers
- Keep-alive Supplies

General Description

The SR086/SR087 are inductorless switching regulators designed to operate directly from a rectified AC line. The operating principle is to turn on a pass transistor when the rectified AC is below the output voltage and to turn it off when the output voltage reaches a specific level. The ICs feature an adjustable main output voltage of 9V to 50V and an additional fixed output of 3.3V for SR086 and 5V for SR087. Efficiencies of around 55% may be realized for loads up to 1W in 120 VAC applications and about 50% efficiencies for loads up to 800 mW in 230 VAC applications.

A logic-level enable input allows the SR086/SR087 to be disabled—useful when they are employed as keep-alive power supplies.

Package Type

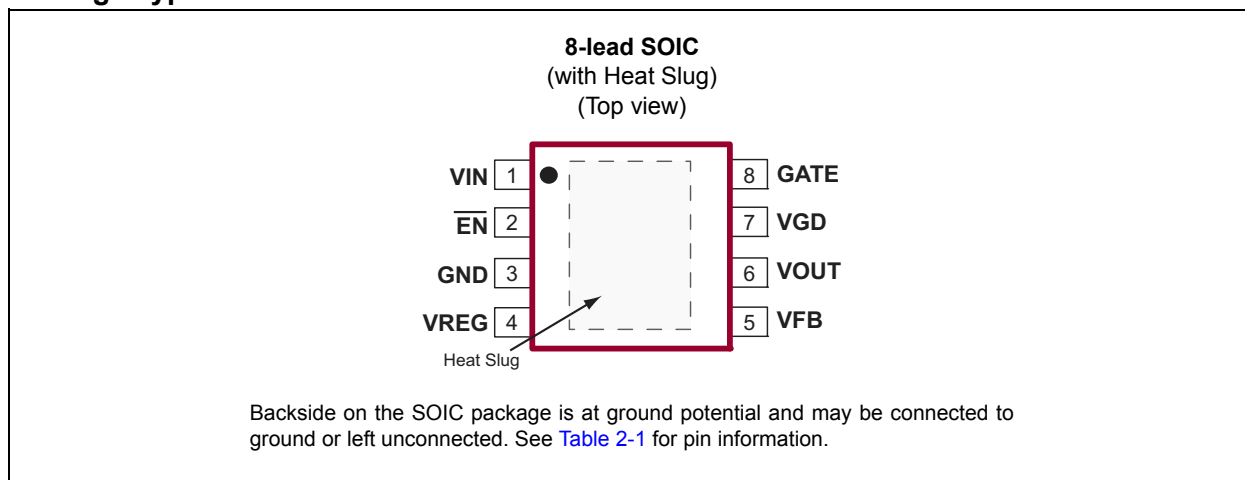

WARNING

Galvanic isolation is not provided. Dangerous voltages are present when connected to the AC line. It is the responsibility of the designer using the SR086/SR087 to ensure that adequate security measures are in place to protect the end user from electrical shock.

The circuits shown in this data sheet are not guaranteed to meet surge and conducted EMI requirements. The effectiveness of these circuits may vary with a particular application. The designer must conduct tests to ascertain compliance with applicable standards and regulations.

SR086/SR087

Functional Block Diagrams

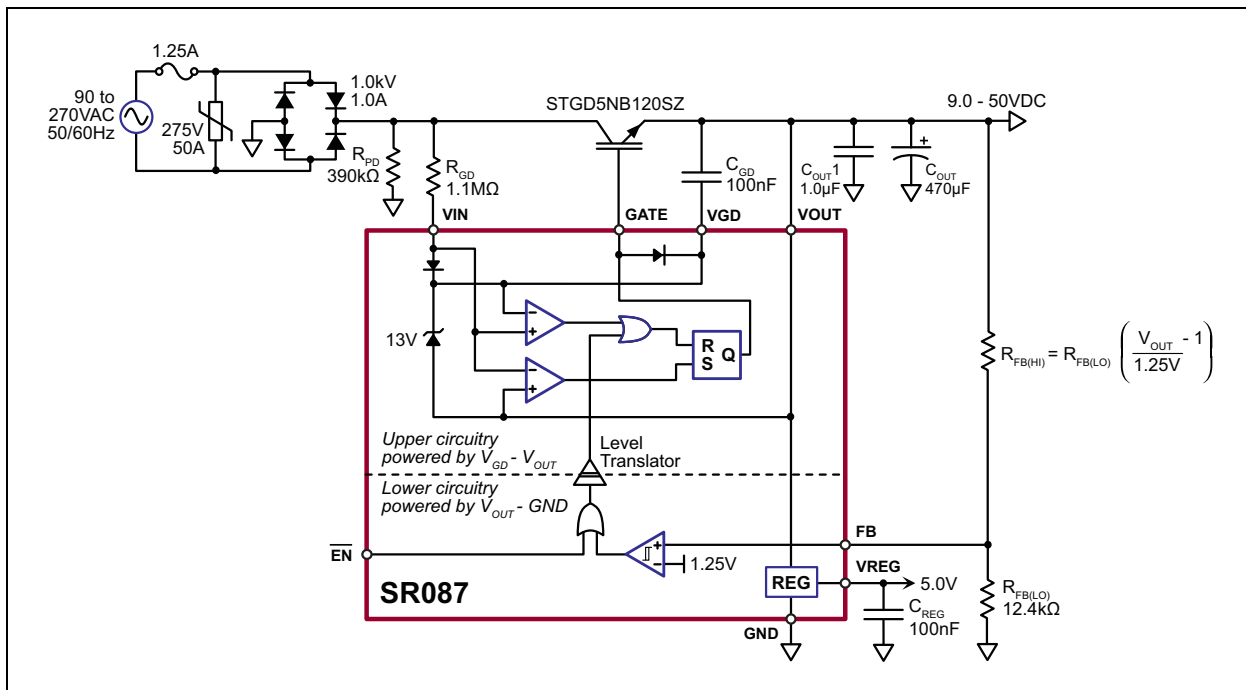
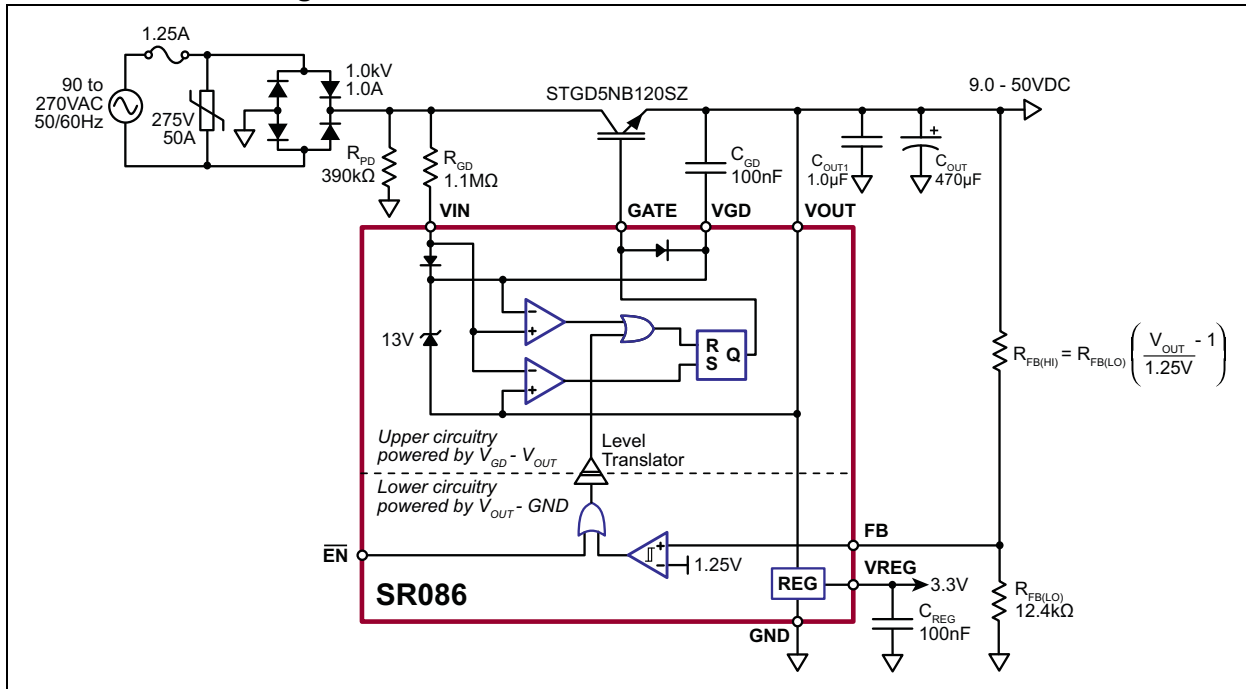

Typical Application Circuits

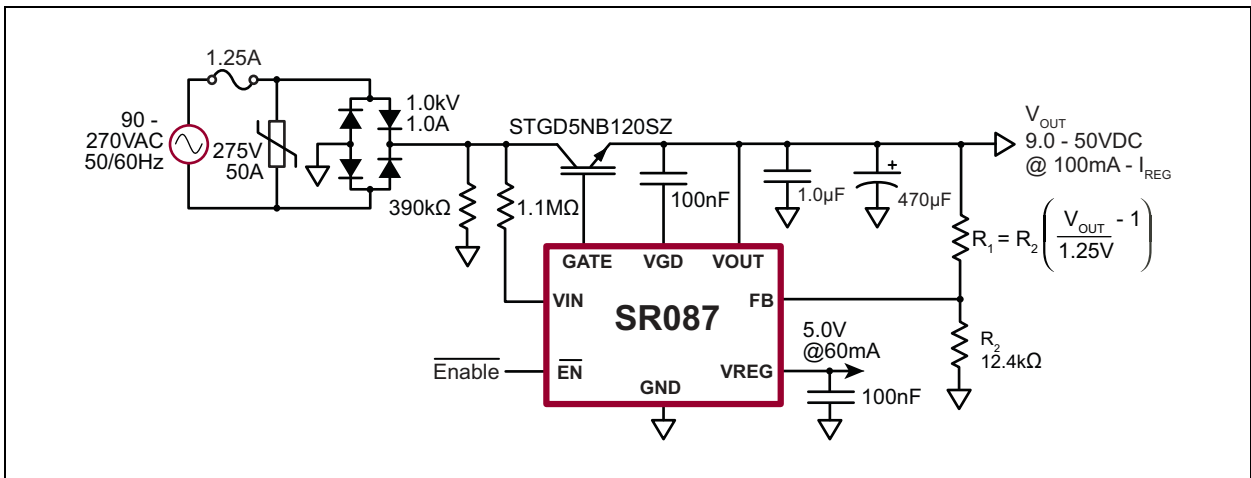
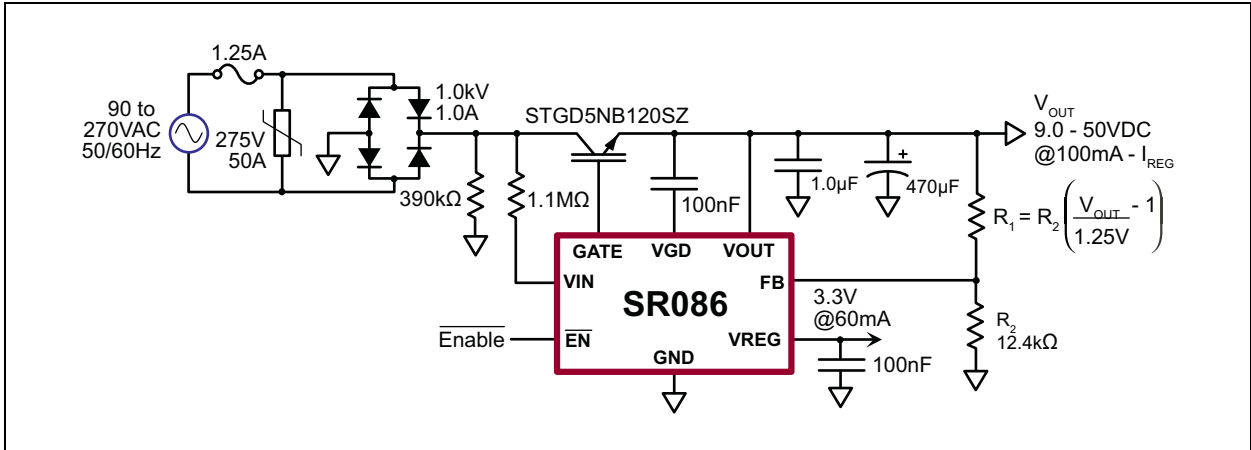

SR086/SR087

1.0 ELECTRICAL CHARACTERISTICS

Absolute Maximum Ratings †

Output Voltage, V_{OUT}	-0.3V to 56V
Feedback Voltage, V_{FB}	-0.3V to 6.5V
Enable Voltage, V_{EN}	-0.3V to 6.5V
Operating Junction Temperature, T_J	-40°C to +125°C

† **Notice:** Stresses above those listed under “Absolute Maximum Ratings” may cause permanent damage to the device. This is a stress rating only, and functional operation of the device at those or any other conditions above those indicated in the operational sections of this specification is not intended. Exposure to maximum rating conditions for extended periods may affect device reliability.

RECOMMENDED OPERATING CONDITIONS

Parameter	Sym.	Min.	Typ.	Max.	Unit	Conditions
Output Voltage	V_{OUT}	9	—	50	V	
Load on V_{OUT} , including Feedback Divider and Load on V_{REG}	I_{OUT}	100	—	—	μ A	
Headroom for Internal Linear Regulation ($V_{OUT}-V_{REG}$)	V_{HR}	4	—	—	V	

ELECTRICAL CHARACTERISTICS

Electrical Specifications: Unless otherwise noted, $T_A = -40^\circ\text{C}$ to $+85^\circ\text{C}$. Voltages referenced to GND pin.							
Parameter	Sym.	Min.	Typ.	Max.	Unit	Conditions	
Current Consumption at V_{GD}	I_{GD}	—	—	60	μ A		
Current Consumption of the Lower Circuitry	$I_{OUT(INT)}$	—	—	400	μ A	$V_{OUT} = 9\text{V}-50\text{V}$	
Gate Drive Supply Voltage	V_{GD}	11	13	15	V	Note 1	
Gate Output High Voltage	$V_{GATE(HI)}$	11	—	15	V	Note 1	
Gate Output Low Voltage	$V_{GATE(LO)}$	—	—	0.5	V	Note 1	
Feedback Voltage (Gate Off)	$V_{FB(OFF)}$	1.18	1.25	1.31	V		
Feedback Voltage (Hysteresis)	$V_{FB(HYST)}$	—	50	—	mV		
Feedback Input Current	I_{FB}	—	—	500	nA		
V_{IN} Trip Voltage (Gate On)	$V_{TRIP(ON)}$	0	—	3	V	Note 1	
V_{IN} Trip Voltage (Gate Off)	$V_{TRIP(OFF)}$	9	—	15	V	Note 1	
Enable Voltage, On	$V_{EN(ON)}$	0.2	—	—	V		
Enable Voltage, Off	$V_{EN(OFF)}$	—	—	0.75	V_{REG}		
V_{IN} Gate Turn-on Delay	$t_{DIG(ON)}$	0	—	1	μ s	$C_{GATE} = 1\text{ nF}$	
V_{IN} Gate Turn-off Delay	$t_{DIG(OFF)}$	—	—	600	ns	$C_{GATE} = 1\text{ nF}$	
Feedback Gate Turn-off Delay	$t_{DFG(OFF)}$	—	—	450	ns	$C_{GATE} = 1\text{ nF}, V_{FB} = 1.5\text{V}$	
Regulated Output Voltage	SR086	V_{REG}	3.125	3.3	3.465	V	$I_{LOAD} = 1\text{ mA}, V_{OUT} = 9\text{V}$
	SR087		4.750	5	5.250	V	
V_{REG} Load Regulation	$\Delta I V_{REG}$	-50	—	+50	mV	$0\text{ mA} < I_{LOAD} < 60\text{ mA}, V_{OUT} = 9\text{V}, T_{AMB} = 25^\circ\text{C}$	
Gate V_{GD} Diode Drop	V_D	—	—	1	V	$I = 20\text{ mA}$	

Note 1: Referenced to V_{OUT}

TEMPERATURE CHARACTERISTICS

Electrical Characteristics: Unless otherwise noted, for all specifications $T_A = T_J = +25^\circ\text{C}$.

Parameter	Sym.	Min.	Typ.	Max.	Unit	Conditions
TEMPERATURE RANGE						
Operating Junction Temperature	T_J	-40	—	+125	$^\circ\text{C}$	
PACKAGE THERMAL RESITANCE						
8-lead SOIC (with Heat Slug)	θ_{JA}	—	84	—	$^\circ\text{C/W}$	

SR086/SR087

SR086 and SR087 Timing Diagram

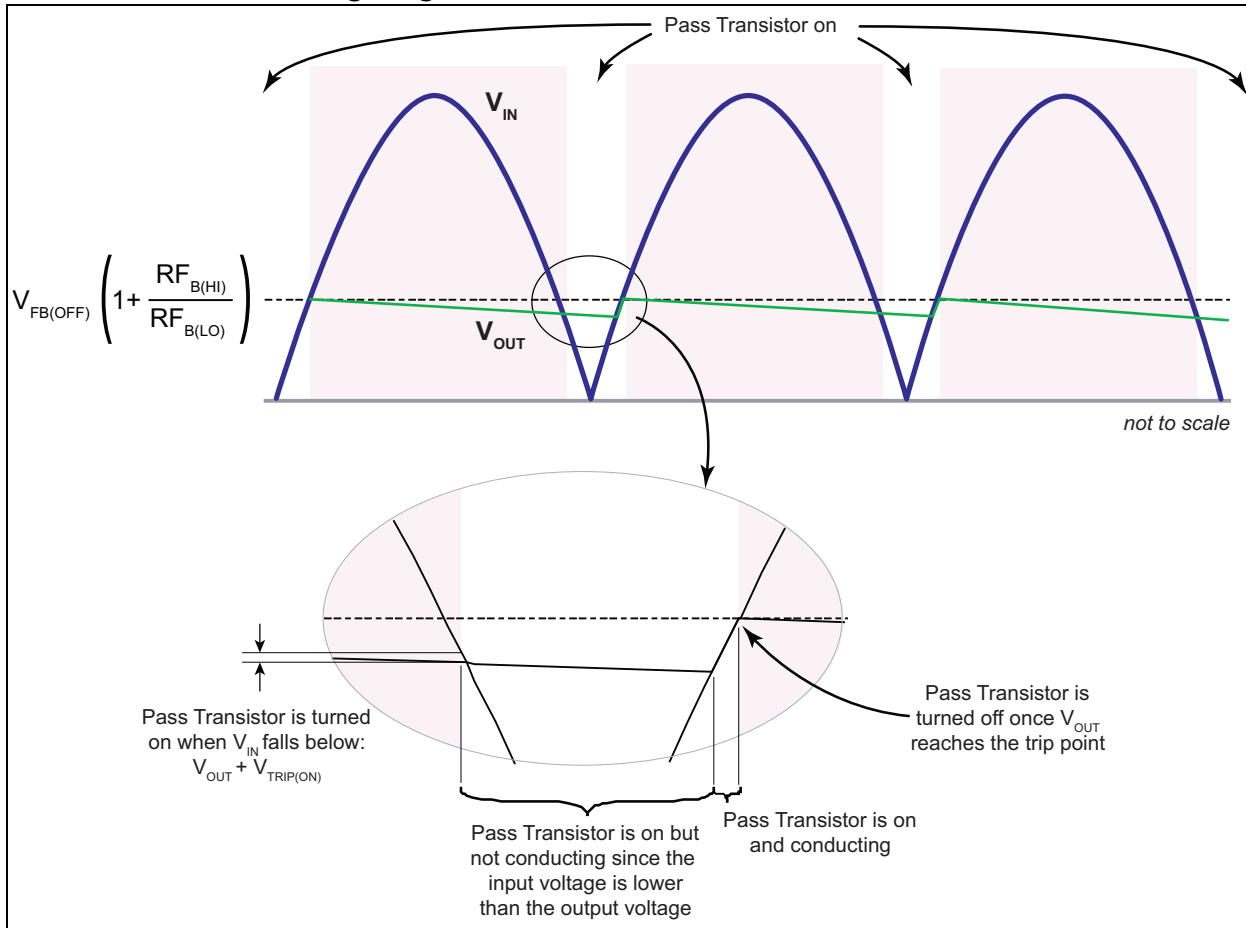

2.0 PIN DESCRIPTION

The descriptions of the SR086/SR087 pins are listed on [Table 2-1](#). Refer to [Package Type](#) for the location of pins.

TABLE 2-1: PIN FUNCTION TABLE

Pin Number	SR086 Pin Name	SR087 Pin Name	Description
1	VIN	VIN	Rectified AC input voltage
2	$\overline{\text{EN}}$	$\overline{\text{EN}}$	Active low enable input
3	GND	GND	Circuit ground (Note 1)
4	VREG	VREG	Regulated output voltage (Note 2)
5	FB	FB	Feedback input
6	VOUT	VOUT	Output voltage (9V–50V adj.)
7	VGD	VGD	Gate drive supply (referenced to VOUT)
8	GATE	GATE	Drives external IGBT pass transistor

Note 1: Circuit ground will be at the AC line potential.

2: Fixed 3.3V for SR086 and fixed 5V for SR087

SR086/SR087

3.0 APPLICATION INFORMATION

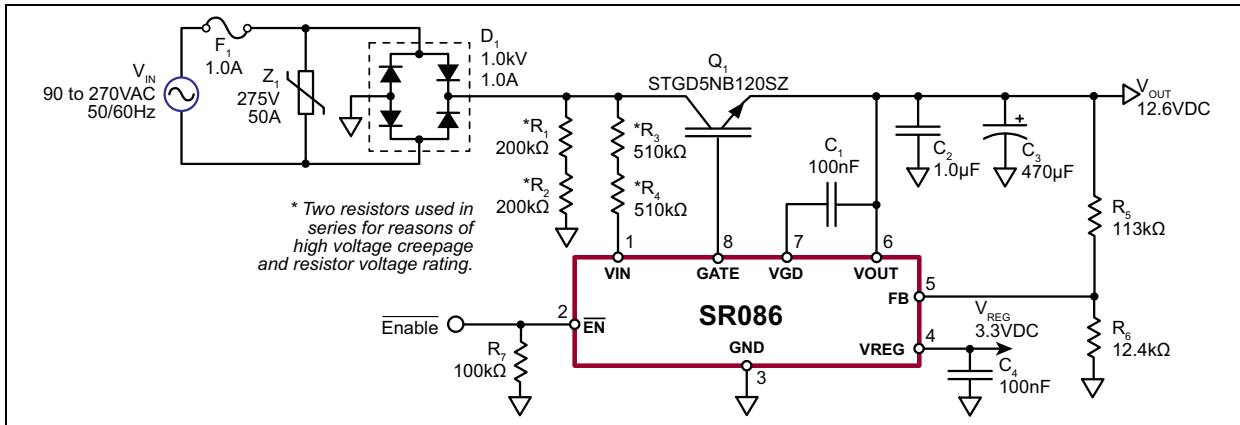

FIGURE 3-1: SR086 Typical Application Circuit.

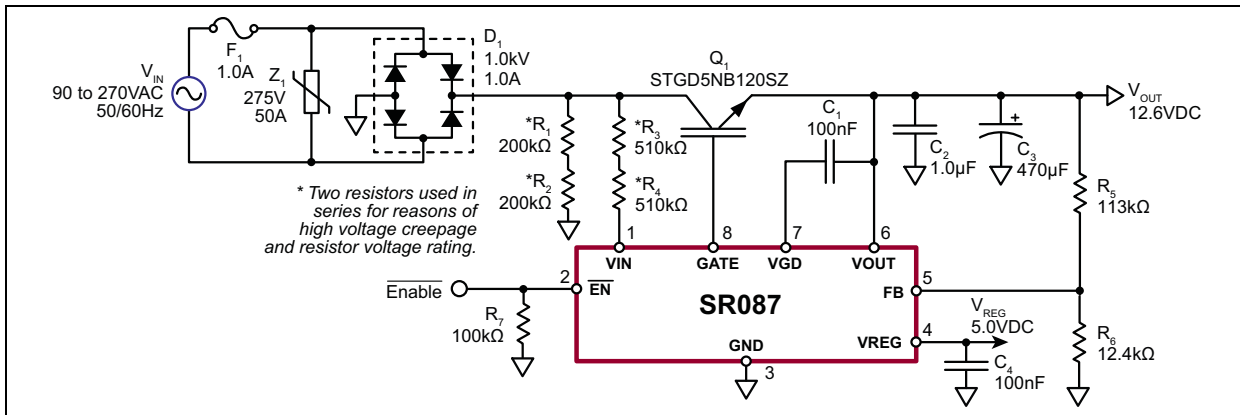

FIGURE 3-2: SR087 Typical Application Circuit.

3.1 Output Voltage

V_{OUT} may be adjusted in the range of 9V to 50V by changing feedback resistor R_5 based on Equation 3-1.

EQUATION 3-1:

$$R_5 = R_6[(V_{OUT}/1.25V) - 1]$$

Leave R_6 at 12.4 kΩ or less as it assures a minimum 100 μA load required for the proper operation of SR086/SR087. Change R_3 and R_4 according to Equation 3-4. Select C_2 and C_3 with appropriate voltage ratings. For C_3 , use a low-ESR capacitor with an adequate ripple current rating (800 mA_{RMS}). Use ceramic for C_2 .

Since V_{REG} is a linear regulator supplied from V_{OUT} , the maximum current available from V_{REG} is reduced as V_{OUT} is increased due to power considerations. Refer to Equation 3-2 for SR086 and Equation 3-3 for SR087.

EQUATION 3-2:

$$I_{REG(MAX)} = \frac{1.5W}{(V_{OUT} - 3.3V)} \text{ or } 60 \text{ mA, whichever is less}$$

EQUATION 3-3:

$$I_{REG(MAX)} = \frac{1.5W}{(V_{OUT} - 5V)} \text{ or } 60 \text{ mA, whichever is less}$$

3.2 Input Voltage

To reduce standby power for 230 VAC-only applications or for supply voltages less than 90 Vrms, R_3 and R_4 should be changed according to Equation 3-4. R_1+R_2 should remain at 400 kΩ or less. Two resistors in series are used to ensure adequate creepage distances for 230 VAC operation. For 120 VAC-only applications, single resistors may be used.

EQUATION 3-4: $R_3 + R_4$ EQUATION

$$(R_3 + R_4) < \frac{\sqrt{2V_{IN}^2 - V_x^2} - V_x \cos 1 \left(\frac{V_x}{\sqrt{2} \times V_{IN}} \right)}{\Pi \times 25 \mu A}$$

Where: $V_x = V_{OUT} + 15V$

Use the minimum anticipated RMS value for V_{IN} . Take resistor tolerance into account, selecting the next lower standard value. Choosing a lower value has no effect other than higher standby power.

3.3 Output Ripple

Storage capacitor C_3 was sized to provide about 2V_{P-P} ripple at 100 mA load ($I_{OUT} + I_{REG}$). For lighter loads, C_3 may be reduced. Conversely, C_3 may be increased for lower ripple. Use a low-ESR capacitor with an adequate ripple current rating (e.g. 800 mA_{RMS} for 100 mA loads). Efficiency and output current capability may drop with increased capacitance because of a smaller conduction angle associated with lower ripple. Due to feedback hysteresis, ripple cannot be reduced below 4%. See [Equation 3-5](#).

EQUATION 3-5:

$$V_{RIPPLE(P-P)} \approx (I_{OUT} + I_{REG}) / 2f_{IN} C_3$$

Note: V_{REG} requires at least 4V of headroom. Therefore, V_{OUT} , including ripple, must not fall below 7.3V for SR086 and 9V for SR087.

3.4 Line Transformer

During initial testing, it is tempting to use an isolation transformer or a variable transformer on the AC line. However, the high inductance of the transformer (frequently in mH range) should not be used because it interferes with the normal operation of the SR086/SR087. This is not a concern with the normal inductance of the AC line or for AC line filters.

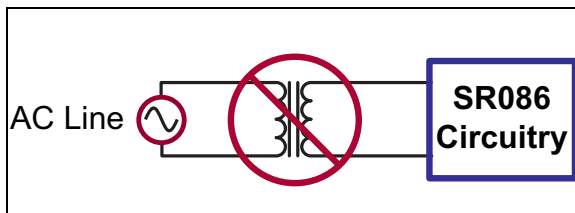

FIGURE 3-3: Line Transformer.

As shown in [Figure 3-3](#), the SR086/SR087 draw current from the AC line (in short, high current pulses). The transformer's high inductance tends to limit the current pulse. Furthermore, inductive kickback on the falling edge of the current pulse can create high voltage spikes which must be absorbed by the transient protector.

3.5 Electromagnetic Interference (EMI) Capacitor

Small-value capacitors from circuit common to earth ground should not be used as they prevent the SR086/SR087 from operating. See [Figure 3-4](#).

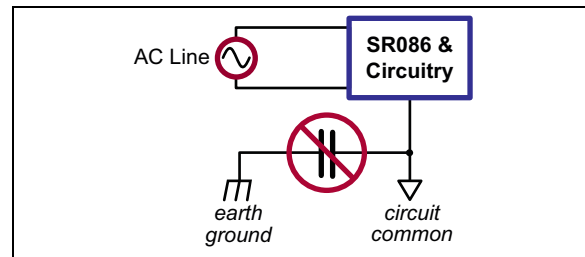

FIGURE 3-4: EMI Capacitor.

3.6 EMI

The SR086/SR087 circuits, as shown in the [Functional Block Diagrams](#), meet FCC Class B and CISPR 14-1 (household appliances) requirements for conducted emissions for combined loads of less than 20 mA ($I_{OUT} + I_{REG}$).

3.7 Fuse

Although the average current drawn from the AC line is low, the RMS current is fairly high due to the current being drawn in short high-current pulses. Since a fuse is basically a resistor with a power dissipation given by $I_{RMS}^2 R$, the fuse must be sized for the RMS current and not the average current. For a 1W load at 120 VAC, the RMS current is 700 mA_{RMS}, while the RMS current for a 0.5W load at 230 VAC is 360 mA_{RMS}.

3.8 Load

Total load on the SR086/SR087 is the total load current drawn from V_{OUT} (I_{OUT}), and since the linear regulator is supplied from V_{OUT} , it also includes the current drawn from V_{REG} (I_{REG}). Total load is calculated in [Equation 3-6](#) and [Equation 3-7](#).

SR086/SR087

EQUATION 3-6:

$$I_{LOAD} = I_{OUT} + I_{REG}$$

EQUATION 3-7:

$$P_{LOAD} = V_{OUT}(I_{OUT} + I_{REG})$$

3.9 Uninterruptible Power Supply (UPS)

The SR086/SR087 will not operate from a UPS with a square wave output. This type of output is usually referred to as “modified sine wave.”

3.10 Transient Protection

The transient protector must be located before the bridge rectifier. The reason for this is to minimize capacitance to allow the rectified AC to fall below V_{OUT} .

Since there is no capacitor to absorb AC line transients, complete transient protection must be provided by the TVS or MOV device. Since the recommended IGBT is rated at 1.2 kV and the SR086/SR087 never see the full input voltage, the bridge rectifier becomes the limiting element when selecting an MOV. When using a 1 kV bridge, an MOV having a clamping voltage of greater than 1 kV is recommended.

An RC network on the AC line, as shown in [Figure 3-5](#) and [Figure 3-6](#), affords additional protection from line transients as well as reducing conducted EMI. It does, however, reduce power supply efficiency.

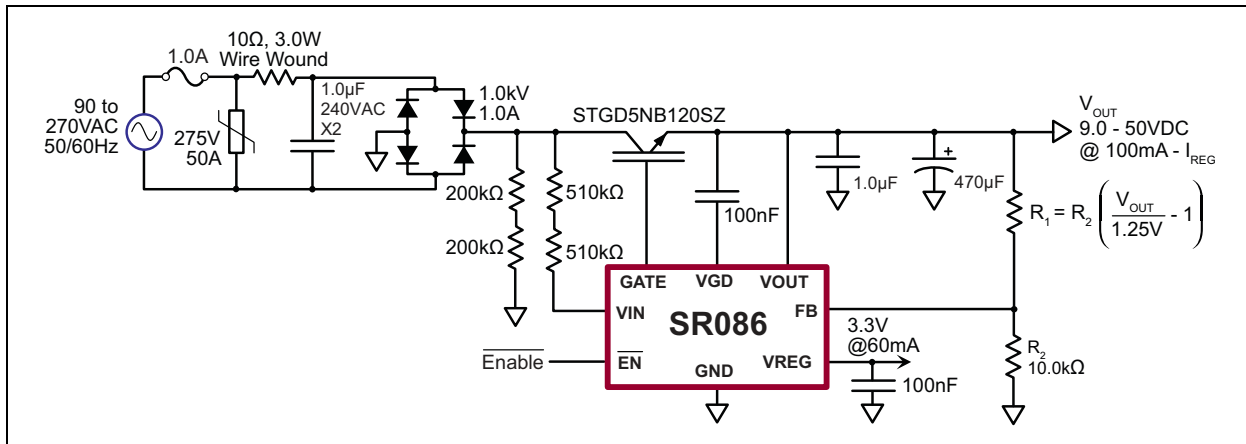

FIGURE 3-5: SR086 Additional Transient Protection.

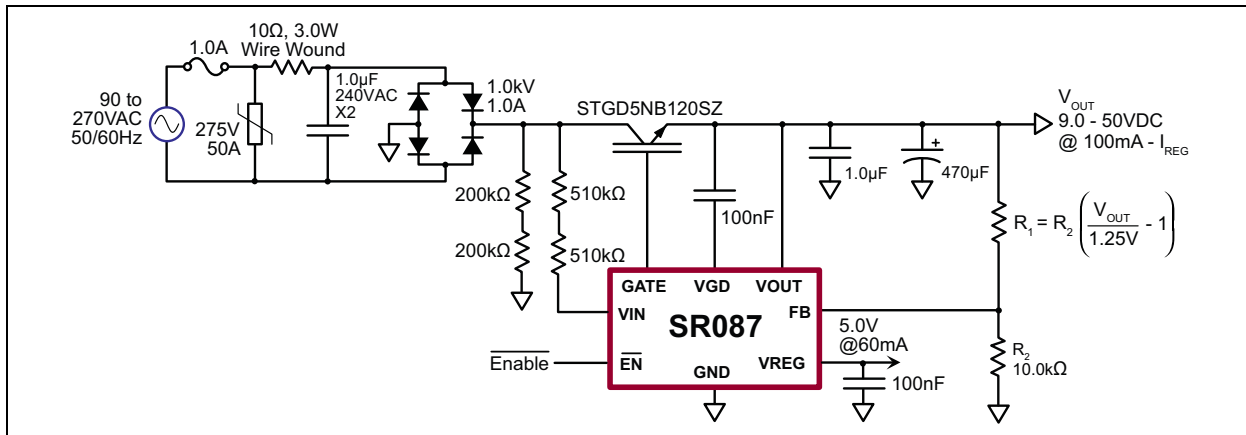
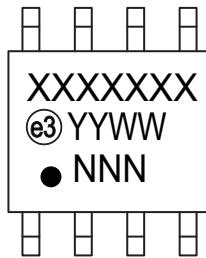

FIGURE 3-6: SR087 Additional Transient Protection.

4.0 PACKAGING INFORMATION

4.1 Package Marking Information

8-lead SOIC



Example

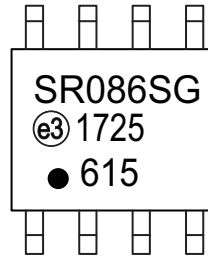

8-lead SOIC

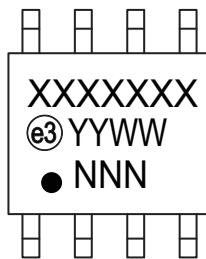

Example



Legend:	XX...X	Product Code or Customer-specific information
	Y	Year code (last digit of calendar year)
	YY	Year code (last 2 digits of calendar year)
	WW	Week code (week of January 1 is week '01')
	NNN	Alphanumeric traceability code
	(e3)	Pb-free JEDEC® designator for Matte Tin (Sn)
	*	This package is Pb-free. The Pb-free JEDEC designator (e3) can be found on the outer packaging for this package.
Note:	In the event the full Microchip part number cannot be marked on one line, it will be carried over to the next line, thus limiting the number of available characters for product code or customer-specific information. Package may or not include the corporate logo.	

SR086/SR087

8-Lead SOIC (Narrow Body w/Heat Slug) Package Outline (SG) 4.90x3.90mm body, 1.70mm height (max), 1.27mm pitch

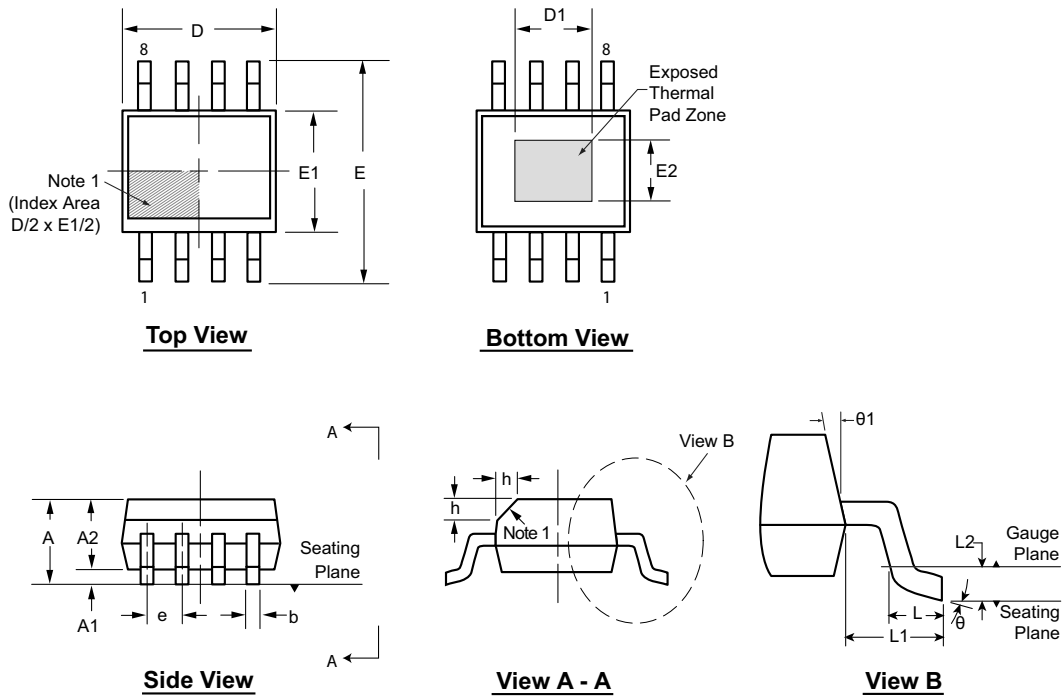

Note: For the most current package drawings, see the Microchip Packaging Specification at www.microchip.com/packaging.

Note:

1. If optional chamfer feature is not present, a Pin 1 identifier must be located in the index area indicated. The Pin 1 identifier can be: a molded mark/identifier; an embedded metal marker; or a printed indicator.

Symbol	A	A1	A2	b	D	D1	E	E1	E2	e	h	L	L1	L2	θ	$\theta 1$			
Dimension (mm)	MIN	1.25*	0.00	1.25	0.31	4.80*	3.30 [†]	5.80*	3.80*	2.29 [†]	1.27 BSC	0.25	0.40	1.04 REF	0.25	0°	5°		
	NOM	-	-	-	-	4.90	-	6.00	3.90	-		-	-		-	-	-	-	-
	MAX	1.70	0.15	1.55*	0.51	5.00*	3.81 [†]	6.20*	4.00*	2.79 [†]		0.50	1.27		-	0.25	8°	15°	

JEDEC Registration MS-012, Variation BA, Issue E, Sept. 2005.

* This dimension is not specified in the JEDEC drawing.

† This dimension differs from the JEDEC drawing.

Drawings not to scale.

APPENDIX A: REVISION HISTORY

Revision A (May 2017)

- Converted and merged Supertex Doc #s DSFP-SR086 and DSFP-SR087 to Microchip DS20005544A
- Changed the package marking format
- Changed the quantity of the SG package from 3000/Reel to 3300/Reel
- Made minor text changes all throughout the document

SR086/SR087

PRODUCT IDENTIFICATION SYSTEM

To order or obtain information, e.g., on pricing or delivery, contact your local Microchip representative or sales office.

<u>PART NO.</u>		<u>XX</u>	-	<u>X</u>	-	<u>X</u>
Device	Package Options			Environmental		Media Type
Devices:	SR086	=		Adjustable Offline Inductorless Switching Regulator with Additional 3.3V Internal Regulator		
	SR087	=		Adjustable Offline Inductorless Switching Regulator with Additional 5V Internal Regulator		
Package:	SG	=		8-lead SOIC (with Heat Slug)		
Environmental:	G	=		Lead (Pb)-free/RoHS-compliant Package		
Media Type:	(blank)	=		3300/Reel for an SG Package		

Examples:	
a) SR086SG-G:	Adjustable Offline Inductorless Switching Regulator with Additional 3.3V Internal Regulator, 8-lead SOIC (with Heat Slug), 3300/Reel
b) SR087SG-G:	Adjustable Offline Inductorless Switching Regulator with Additional 5V Internal Regulator, 8-lead SOIC (with Heat Slug), 3300/Reel

Note the following details of the code protection feature on Microchip devices:

- Microchip products meet the specification contained in their particular Microchip Data Sheet.
- Microchip believes that its family of products is one of the most secure families of its kind on the market today, when used in the intended manner and under normal conditions.
- There are dishonest and possibly illegal methods used to breach the code protection feature. All of these methods, to our knowledge, require using the Microchip products in a manner outside the operating specifications contained in Microchip's Data Sheets. Most likely, the person doing so is engaged in theft of intellectual property.
- Microchip is willing to work with the customer who is concerned about the integrity of their code.
- Neither Microchip nor any other semiconductor manufacturer can guarantee the security of their code. Code protection does not mean that we are guaranteeing the product as “unbreakable.”

Code protection is constantly evolving. We at Microchip are committed to continuously improving the code protection features of our products. Attempts to break Microchip's code protection feature may be a violation of the Digital Millennium Copyright Act. If such acts allow unauthorized access to your software or other copyrighted work, you may have a right to sue for relief under that Act.

Information contained in this publication regarding device applications and the like is provided only for your convenience and may be superseded by updates. It is your responsibility to ensure that your application meets with your specifications. MICROCHIP MAKES NO REPRESENTATIONS OR WARRANTIES OF ANY KIND WHETHER EXPRESS OR IMPLIED, WRITTEN OR ORAL, STATUTORY OR OTHERWISE, RELATED TO THE INFORMATION, INCLUDING BUT NOT LIMITED TO ITS CONDITION, QUALITY, PERFORMANCE, MERCHANTABILITY OR FITNESS FOR PURPOSE. Microchip disclaims all liability arising from this information and its use. Use of Microchip devices in life support and/or safety applications is entirely at the buyer's risk, and the buyer agrees to defend, indemnify and hold harmless Microchip from any and all damages, claims, suits, or expenses resulting from such use. No licenses are conveyed, implicitly or otherwise, under any Microchip intellectual property rights unless otherwise stated.

Microchip received ISO/TS-16949:2009 certification for its worldwide headquarters, design and wafer fabrication facilities in Chandler and Tempe, Arizona; Gresham, Oregon and design centers in California and India. The Company's quality system processes and procedures are for its PIC® MCUs and dsPIC® DSCs, KEELOQ® code hopping devices, Serial EEPROMs, microperipherals, nonvolatile memory and analog products. In addition, Microchip's quality system for the design and manufacture of development systems is ISO 9001:2000 certified.

**QUALITY MANAGEMENT SYSTEM
CERTIFIED BY DNV
= ISO/TS 16949 =**

Trademarks

The Microchip name and logo, the Microchip logo, AnyRate, AVR, AVR logo, AVR Freaks, BeaconThings, BitCloud, CryptoMemory, CryptoRF, dsPIC, FlashFlex, flexPWR, Helder, JukeBlox, KEELOQ, KEELOQ logo, Klear, LANCheck, LINK MD, maXStylus, maXTouch, MediaLB, megaAVR, MOST, MOST logo, MPLAB, OptoLyzer, PIC, picoPower, PICSTART, PIC32 logo, Prochip Designer, QTouch, RightTouch, SAM-BA, SpyNIC, SST, SST Logo, SuperFlash, tinyAVR, UNI/O, and XMEGA are registered trademarks of Microchip Technology Incorporated in the U.S.A. and other countries.

ClockWorks, The Embedded Control Solutions Company, EtherSynch, Hyper Speed Control, HyperLight Load, IntelliMOS, mTouch, Precision Edge, and Quiet-Wire are registered trademarks of Microchip Technology Incorporated in the U.S.A.

Adjacent Key Suppression, AKS, Analog-for-the-Digital Age, Any Capacitor, AnyIn, AnyOut, BodyCom, chipKIT, chipKIT logo, CodeGuard, CryptoAuthentication, CryptoCompanion, CryptoController, dsPICDEM, dsPICDEM.net, Dynamic Average Matching, DAM, ECAN, EtherGREEN, In-Circuit Serial Programming, ICSP, Inter-Chip Connectivity, JitterBlocker, KlearNet, KlearNet logo, Mindi, MiWi, motorBench, MPASM, MPF, MPLAB Certified logo, MPLIB, MPLINK, MultiTRAK, NetDetach, Omniscient Code Generation, PICDEM, PICDEM.net, PICKit, PICTail, PureSilicon, QMatrix, RightTouch logo, REAL ICE, Ripple Blocker, SAM-ICE, Serial Quad I/O, SMART-I.S., SQI, SuperSwitcher, SuperSwitcher II, Total Endurance, TSHARC, USBCheck, VariSense, ViewSpan, WiperLock, Wireless DNA, and ZENA are trademarks of Microchip Technology Incorporated in the U.S.A. and other countries.

SQTP is a service mark of Microchip Technology Incorporated in the U.S.A.

Silicon Storage Technology is a registered trademark of Microchip Technology Inc. in other countries.

GestIC is a registered trademark of Microchip Technology Germany II GmbH & Co. KG, a subsidiary of Microchip Technology Inc., in other countries.

All other trademarks mentioned herein are property of their respective companies.

© 2017, Microchip Technology Incorporated, All Rights Reserved.
ISBN: 978-1-5224-1738-5



MICROCHIP

Worldwide Sales and Service

AMERICAS

Corporate Office
2355 West Chandler Blvd.
Chandler, AZ 85224-6199
Tel: 480-792-7200
Fax: 480-792-7277
Technical Support:
<http://www.microchip.com/support>
Web Address:
www.microchip.com

Atlanta
Duluth, GA
Tel: 678-957-9614
Fax: 678-957-1455

Austin, TX
Tel: 512-257-3370

Boston
Westborough, MA
Tel: 774-760-0087
Fax: 774-760-0088

Chicago
Itasca, IL
Tel: 630-285-0071
Fax: 630-285-0075

Dallas
Addison, TX
Tel: 972-818-7423
Fax: 972-818-2924

Detroit
Novi, MI
Tel: 248-848-4000

Houston, TX
Tel: 281-894-5983

Indianapolis
Noblesville, IN
Tel: 317-773-8323
Fax: 317-773-5453
Tel: 317-536-2380

Los Angeles
Mission Viejo, CA
Tel: 949-462-9523
Fax: 949-462-9608
Tel: 951-273-7800

Raleigh, NC
Tel: 919-844-7510

New York, NY
Tel: 631-435-6000

San Jose, CA
Tel: 408-735-9110
Tel: 408-436-4270

Canada - Toronto
Tel: 905-695-1980
Fax: 905-695-2078

ASIA/PACIFIC

Asia Pacific Office
Suites 3707-14, 37th Floor
Tower 6, The Gateway
Harbour City, Kowloon

Hong Kong
Tel: 852-2943-5100
Fax: 852-2401-3431

Australia - Sydney
Tel: 61-2-9868-6733
Fax: 61-2-9868-6755

China - Beijing
Tel: 86-10-8569-7000
Fax: 86-10-8528-2104

China - Chengdu
Tel: 86-28-8665-5511
Fax: 86-28-8665-7889

China - Chongqing
Tel: 86-23-8980-9588
Fax: 86-23-8980-9500

China - Dongguan
Tel: 86-769-8702-9880

China - Guangzhou
Tel: 86-20-8755-8029

China - Hangzhou
Tel: 86-571-8792-8115
Fax: 86-571-8792-8116

China - Hong Kong SAR
Tel: 852-2943-5100
Fax: 852-2401-3431

China - Nanjing
Tel: 86-25-8473-2460
Fax: 86-25-8473-2470

China - Qingdao
Tel: 86-532-8502-7355
Fax: 86-532-8502-7205

China - Shanghai
Tel: 86-21-3326-8000
Fax: 86-21-3326-8021

China - Shenyang
Tel: 86-24-2334-2829
Fax: 86-24-2334-2393

China - Shenzhen
Tel: 86-755-8864-2200
Fax: 86-755-8203-1760

China - Wuhan
Tel: 86-27-5980-5300
Fax: 86-27-5980-5118

China - Xian
Tel: 86-29-8833-7252
Fax: 86-29-8833-7256

ASIA/PACIFIC

China - Xiamen
Tel: 86-592-2388138
Fax: 86-592-2388130

China - Zhuhai
Tel: 86-756-3210040
Fax: 86-756-3210049

India - Bangalore
Tel: 91-80-3090-4444
Fax: 91-80-3090-4123

India - New Delhi
Tel: 91-11-4160-8631
Fax: 91-11-4160-8632

India - Pune
Tel: 91-20-3019-1500

Japan - Osaka
Tel: 81-6-6152-7160
Fax: 81-6-6152-9310

Japan - Tokyo
Tel: 81-3-6880-3770
Fax: 81-3-6880-3771

Korea - Daegu
Tel: 82-53-744-4301
Fax: 82-53-744-4302

Korea - Seoul
Tel: 82-2-554-7200
Fax: 82-2-558-5932 or
82-2-558-5934

Malaysia - Kuala Lumpur
Tel: 60-3-6201-9857
Fax: 60-3-6201-9859

Malaysia - Penang
Tel: 60-4-227-8870
Fax: 60-4-227-4068

Philippines - Manila
Tel: 63-2-634-9065
Fax: 63-2-634-9069

Singapore
Tel: 65-6334-8870
Fax: 65-6334-8850

Taiwan - Hsin Chu
Tel: 886-3-5778-366
Fax: 886-3-5770-955

Taiwan - Kaohsiung
Tel: 886-7-213-7830

Taiwan - Taipei
Tel: 886-2-2508-8600
Fax: 886-2-2508-0102

Thailand - Bangkok
Tel: 66-2-694-1351
Fax: 66-2-694-1350

EUROPE

Austria - Wels
Tel: 43-7242-2244-39
Fax: 43-7242-2244-393

Denmark - Copenhagen
Tel: 45-4450-2828
Fax: 45-4485-2829

Finland - Espoo
Tel: 358-9-4520-820

France - Paris
Tel: 33-1-69-53-63-20
Fax: 33-1-69-30-90-79

France - Saint Cloud
Tel: 33-1-30-60-70-00

Germany - Garching
Tel: 49-8931-9700

Germany - Haan
Tel: 49-2129-3766400

Germany - Heilbronn
Tel: 49-7131-67-3636

Germany - Karlsruhe
Tel: 49-721-625370

Germany - Munich
Tel: 49-89-627-144-0
Fax: 49-89-627-144-44

Germany - Rosenheim
Tel: 49-8031-354-560

Israel - Ra'anana
Tel: 972-9-744-7705

Italy - Milan
Tel: 39-0331-742611
Fax: 39-0331-466781

Italy - Padova
Tel: 39-049-7625286

Netherlands - Drunen
Tel: 31-416-690399
Fax: 31-416-690340

Norway - Trondheim
Tel: 47-7289-7561

Poland - Warsaw
Tel: 48-22-3325737

Romania - Bucharest
Tel: 40-21-407-87-50

Spain - Madrid
Tel: 34-91-708-08-90
Fax: 34-91-708-08-91

Sweden - Gothenberg
Tel: 46-31-704-60-40

Sweden - Stockholm
Tel: 46-8-5090-4654

UK - Wokingham
Tel: 44-118-921-5800
Fax: 44-118-921-5820