

MSP430FG4618/F2013 Experimenter Board (MSP-EXP430FG4618)

The [MSP430FG4618/F2013 Experimenter Board](#) is a comprehensive development target board that can be used for a number of applications. The MSP-EXP430FG4618 kit comes with one MSP430FG4618/F2013 experimenter board (see [Figure 1](#)) and two AAA 1.5-V batteries.

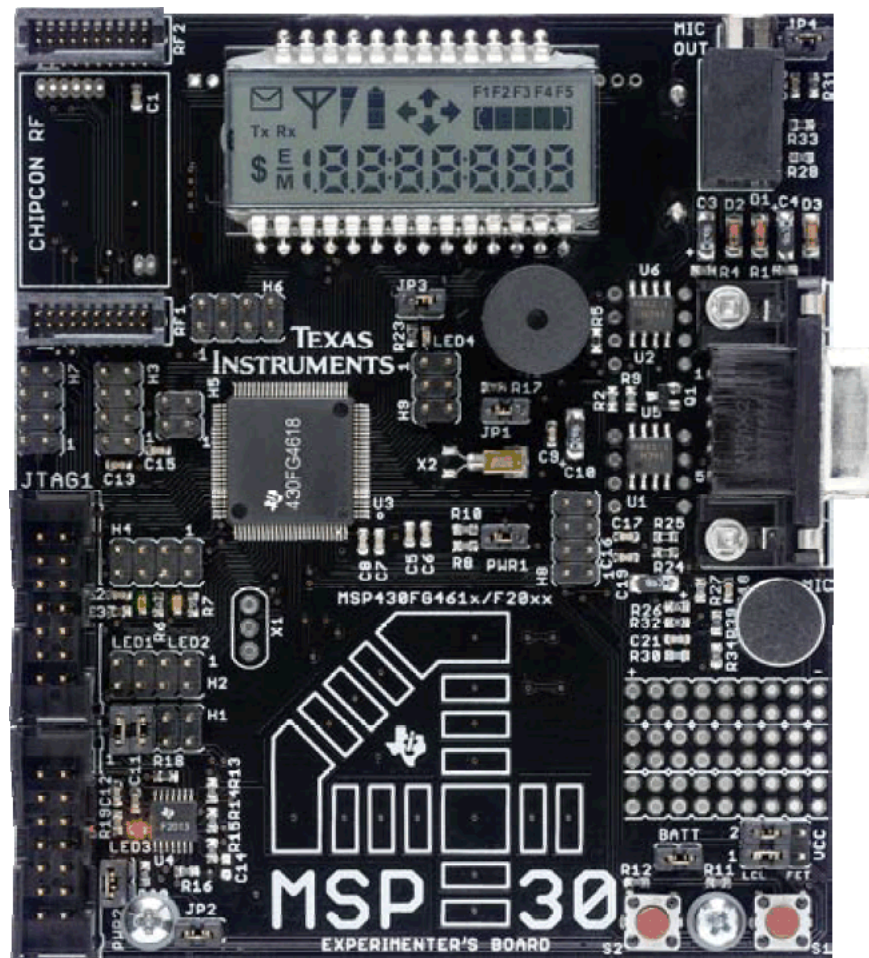

Figure 1. MSP430FG4618/F2013 Experimenter Board

Contents

1	Devices Supported	3
2	If You Need Assistance	3
3	Required Tools	3
4	Functional Overview	3
5	Hardware Installation	4
6	Hardware Overview.....	5
	6.1 Interfaces	5
	6.2 Communication Peripherals	5
	6.3 Analog Signal Chain.....	6
	6.4 System Clocks	7
	6.5 Jumper Configurations	8
7	Frequently Asked Questions	9
8	Schematic	11
9	References	12

List of Figures

1	MSP430FG4618/F2013 Experimenter Board	1
2	MSP-EXP430FG4618 Block Diagram	3
3	Jumper Settings for Power Selection	4
4	Analog Signal Chain of MSP430 MCU	6
5	Active Analog Filter	7
6	Jumper Locations.....	8
7	MSP-EXP430FG4618 Schematic	11

List of Tables

1	Jumper Settings and Functionality	9
---	-----------------------------------------	---

Trademarks

MSP430, E2E, MSP430Ware are trademarks of Texas Instruments.
All other trademarks are the property of their respective owners.

1 Devices Supported

The MSP430FG4618/F2013 experimenter board is based on the [Texas Instruments ultra-low power MSP430™ microcontrollers](#). This board includes the [MSP430FG4618](#) and the [MSP430F2013](#) microcontrollers.

2 If You Need Assistance

If you need additional assistance with this experimenter board, visit the [TI E2E™ Community forums](#).

3 Required Tools

A flash emulation tool for MSP430 MCUs ([MSP-FET](#)) is required to download code and debug the MSP430FG4618 and MSP430F2013. Two separate JTAG headers are available, supporting independent debug environments. The MSP430FG4618 uses the standard 4-wire JTAG connection while the MSP430F2013 uses the Spy-Bi-wire (2-wire) JTAG interface allowing all port pins to be used during debug. For more details on the flash emulation tool, see the [MSP Debuggers User's Guide](#).

4 Functional Overview

The MSP430FG4618/F2013 experimenter board supports various applications through the use of the on-chip peripherals connecting to a number of onboard components and interfaces (see [Figure 2](#)).

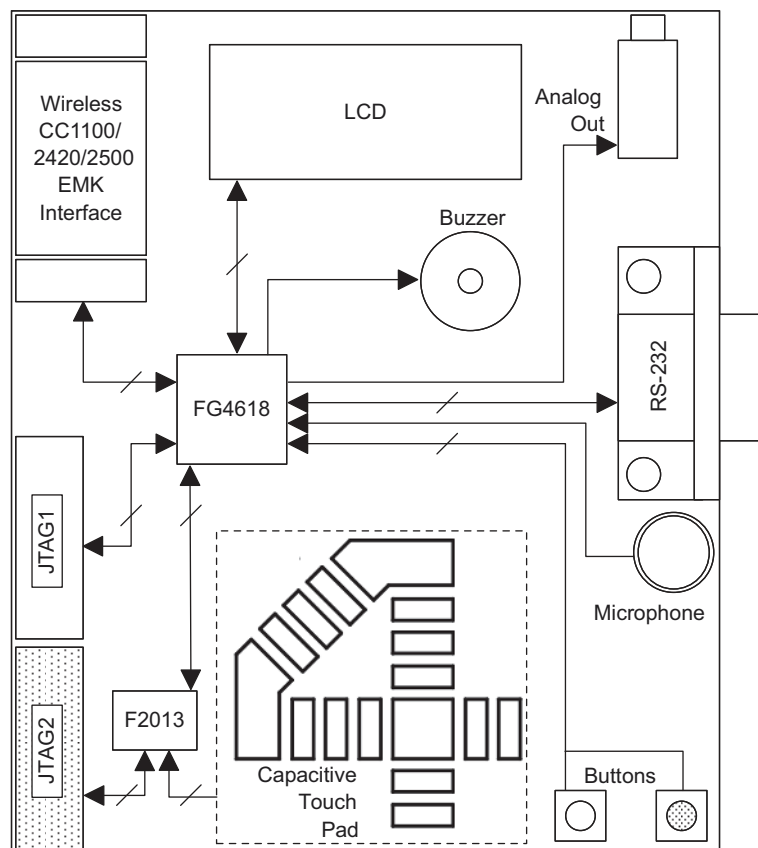

Figure 2. MSP-EXP430FG4618 Block Diagram

Wireless communication is possible through the expansion header, which is compatible with all Wireless Evaluation Modules from Texas Instruments. Interface to a 4-mux LCD, UART connection, microphone, audio output jack, buzzer, and single touch capacitive touch pad enable the development of a variety of applications. Communication between the two onboard microcontrollers is also possible. In addition, all pins of the MSP430FG4618 are made available either through headers or interfaces for easy debugging. [MSP430Ware™ for MSP Microcontrollers](#) includes sample code for this board.

5 Hardware Installation

Power may be provided locally from two onboard AAA batteries, externally from a FET, or from an external supply. The power source is selected by configuring jumpers VCC_1, VCC_2, and BATT. PWR1 and PWR2 independently control the power supply to each MSP430 MCU. See [Section 6.5.1](#) the location of these jumpers. [Figure 3](#) shows the jumper hierarchy and configuration options.

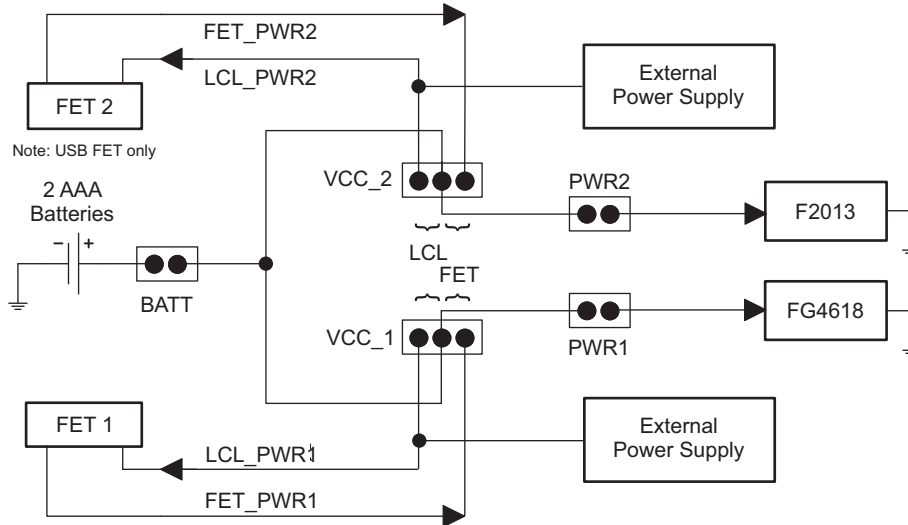

Figure 3. Jumper Settings for Power Selection

The battery jumper BATT is used to select the onboard batteries to power the system, independent of the FET connections. The user must ensure that this voltage meets the requirement for proper functionality of the MSP430 MCU.

The power selection jumpers VCC_1 and VCC_2 select the power connections between the board and each FET interface. These jumpers are two rows of 3-pin headers, one for each MSP430 onboard. VCC_1, the bottom row, is for the MSP430FG4618 and, VCC_2 on the top row, is for the MSP430F2013. A jumper placed on the right 2 pins (FET) selects the JTAG FET as the power source. A jumper placed on the left 2 pins (LCL) enables local power (either from the batteries or an external supply) to be applied to each FET for proper logic threshold level matching during program and debug.

Headers PWR1 and PWR2 have been provided to enable power to the individual MSP430s. A jumper placed on PWR1 provides power to the MSP430FG4618 and a jumper placed on PWR2 provides power to the MSP430F2013. Individual device current consumption can be measured through each of these jumpers. Do not make interconnections to the MSP430 MCU that could influence such a measurement.

When the required power selections have been made, the experimenter board is ready to be used. Both the MSP430FG4618 and MSP430F2013 are factory programmed. After power up, the MSP430FG4618 executes an ultra-low-power real-time clock displayed on the LCD. The MSP430F2013 pulses LED3 from LPM3 using the VLO for periodic wakeup.

6 Hardware Overview

This section contains information about the various onboard interfaces and their functionality and about the various peripherals enabling these interfaces. Wireless applications are facilitated using the capabilities of the MSP430 MCUs to interface with the wireless evaluation modules (CCxxxxEMK) from TI. The onboard LEDs and LCD display give visual feedback. Audio applications that leverage the full analog signal chain of the MSP430FG4618 can be implemented using the microphone and the audio output jack. In addition, communication across components on and off the board has been integrated.

6.1 Interfaces

Some of these interfaces have the option of being inactive when not in use to conserve power. This is made possible by port pin configurations on the MSP430 MCUs or hardware jumpers on the experimenter board. For details of the jumper configurations and positions, see [Section 6.5.1](#).

6.1.1 4-Mux LCD Display

The integrated SoftBaugh SBLCDA4 LCD display supports 4-MUX operation and interfaces to the LCD driver peripheral of the MSP430FG4618. More information on the LCD can be obtained from the [SoftBaugh website](#).

6.1.2 Momentary-On Push Buttons

Two external push buttons (S1 and S2) connect to port P1, an interrupt-capable digital I/O port on the MSP430FG4618.

6.1.3 Light Emitting Diodes (LEDs)

The experimenter board has four LEDs. Three connect to the MSP430FG4618, and one connects to the MSP430F2013. The LEDs are primarily used for display purposes. Two of the LEDs can be disconnected using jumpers to reduce the overall power consumption of the board.

6.1.4 Buzzer

A buzzer connects to and is driven by a digital I/O port of the MSP430FG4618. The buzzer can be disconnected by jumper JP1.

6.1.5 Single-Touch Sensing Interface

A capacitive touch sensing interface in the shape of a "4" is provided. This touchpad is connected to the digital I/O ports of the MSP430F2013. A total of 16 individual segments form the touchpad, and the MSP430F2013 monitors activity on the touchpad. The resulting data is communicated to the MSP430FG4618 through the onboard MCU intercommunication connections.

6.2 Communication Peripherals

The experimenter board supports numerous communication interfaces for onboard and offboard connections.

6.2.1 Wireless Evaluation Module Interface

Interface to the wireless world is accomplished through the wireless evaluation module header supporting the CCxxxxEMK boards. The transceiver modules are connected to the USART of the MSP430FG4618 configured in SPI mode. For libraries that interface the MSP430 MCUs, visit the [CC2500 product page](#). The CC2420EMK (obsolete) supports the IEEE 802.15.4 and Zigbee standards. The CC1100EMK (obsolete) supports an RF carrier frequency up to 868 MHz, and the CC2500EMK and CC2420EMK support an RF carrier frequency of 2.4 GHz.

6.2.2 RS-232

For a serial interface to a PC, the MSP430FG4618 supports the standard RS-232 9-pin interface through its USCI peripheral configured in UART mode. Software can configure standard baud rates for transmission and reception.

6.2.3 I²C and SPI

The MSP430FG4618 and the MSP430F2013 support I²C and SPI protocols through the USCI and the USI peripherals for inter-processor communication. The links can be disconnected in hardware to use these peripherals for other communication purposes.

6.3 Analog Signal Chain

The experimenter board can form a complete analog signal chain using the MSP430FG4618. This board can be used for numerous audio applications. The board can record and play audio signals without the use of additional external components.

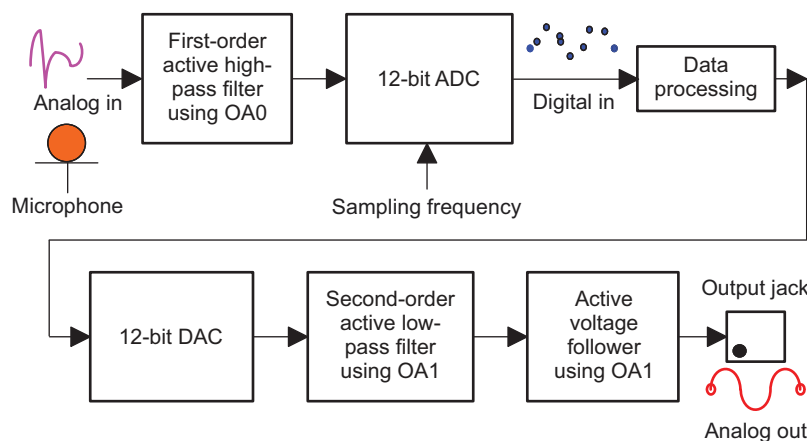

Figure 4. Analog Signal Chain of MSP430 MCU

6.3.1 Microphone

The microphone is connected to the MSP430FG4618 and may be used for various applications. The microphone is enabled or disabled through a port pin connected to the MSP430FG4618.

6.3.2 Analog Filters

An active first-order high-pass filter (HPF) with a cut-off frequency of approximately 340 Hz follows the microphone to eliminate extremely low input frequencies. An optional second-order Sallen-Key active low-pass filter (LPF) with a cut-off frequency of approximately 4 kHz removes the high-frequency noise on the analog output of the 12-bit DAC. [Figure 5](#) shows the filter setup. These filters use the integrated op-amps of the MSP430 MCU. The op-amps OA0 and OA1 facilitate the filtering processes. The gray blocks in [Figure 5](#) are elements that are internal to the MSP430FG4618.

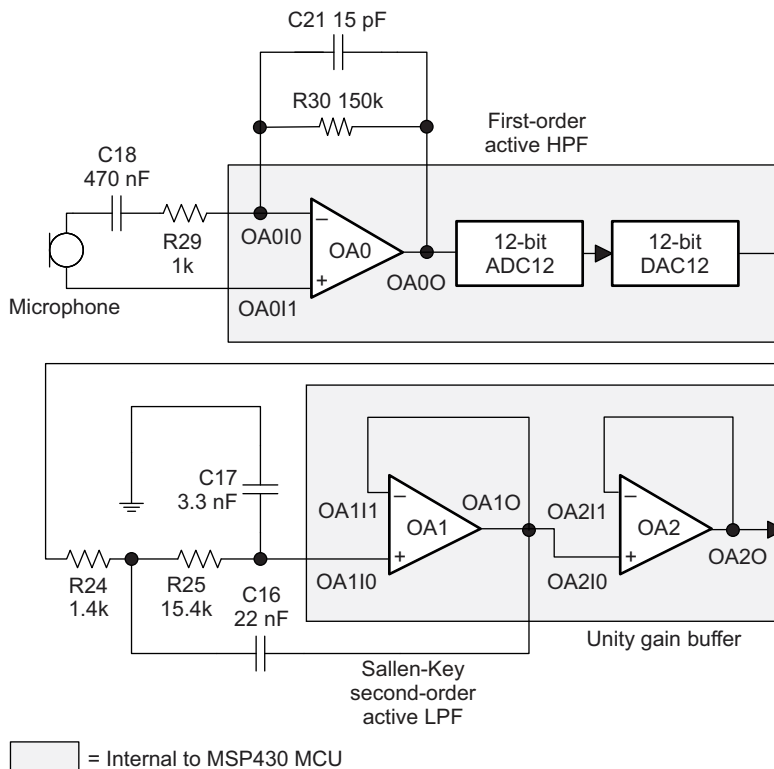

Figure 5. Active Analog Filter

6.3.3 Analog Output

Analog output can be brought out of the board through a mono 3.5-mm jack connected to the integrated op-amp OA2. The input to this amplifier can be internally connected to the DAC12 output of the MSP430FG4618. Several attenuation options are provided internally and in hardware using jumper JP4.

6.4 System Clocks

The experimenter board has various system clock options that support low and high frequencies. Each MSP430 MCU has integrated clock sources and support for external connections.

6.4.1 MSP430F2013 Clock Sources

The MSP430F2013 uses the internal VLO operating at approximately 12 kHz for an ultra-low-power standby wake-up time base. The integrated DCO is internally programmable at frequencies up to 16 MHz for high-speed CPU and system clocking.

6.4.2 MSP430FG4618 Clock Sources

A standard 32.768-kHz watch crystal is populated at footprint X2 and sources source ACLK of the MSP430FG4618 for low-frequency ultra-low-power standby operation and RTC functionality. The integrated FLL+ clock module provides a programmable internal high-frequency clock source for the CPU and other on-chip peripherals. In addition to the FLL+, an external high-frequency crystal or resonator up to 8 MHz can be added to footprint X1.

6.5 Jumper Configurations

The board can enable various peripherals and components when they are required and disabled them when not in use to reduce overall power consumption. This is achieved either by software or directly in hardware. Some of the jumpers are mandatory for the board to function correctly. [Section 6.5.1](#) describes the jumpers and their locations.

6.5.1 Jumper Locations and Settings

[Figure 6](#) shows the location and name of each jumper on the experimenter board. [Table 1](#) lists the function of each jumper.

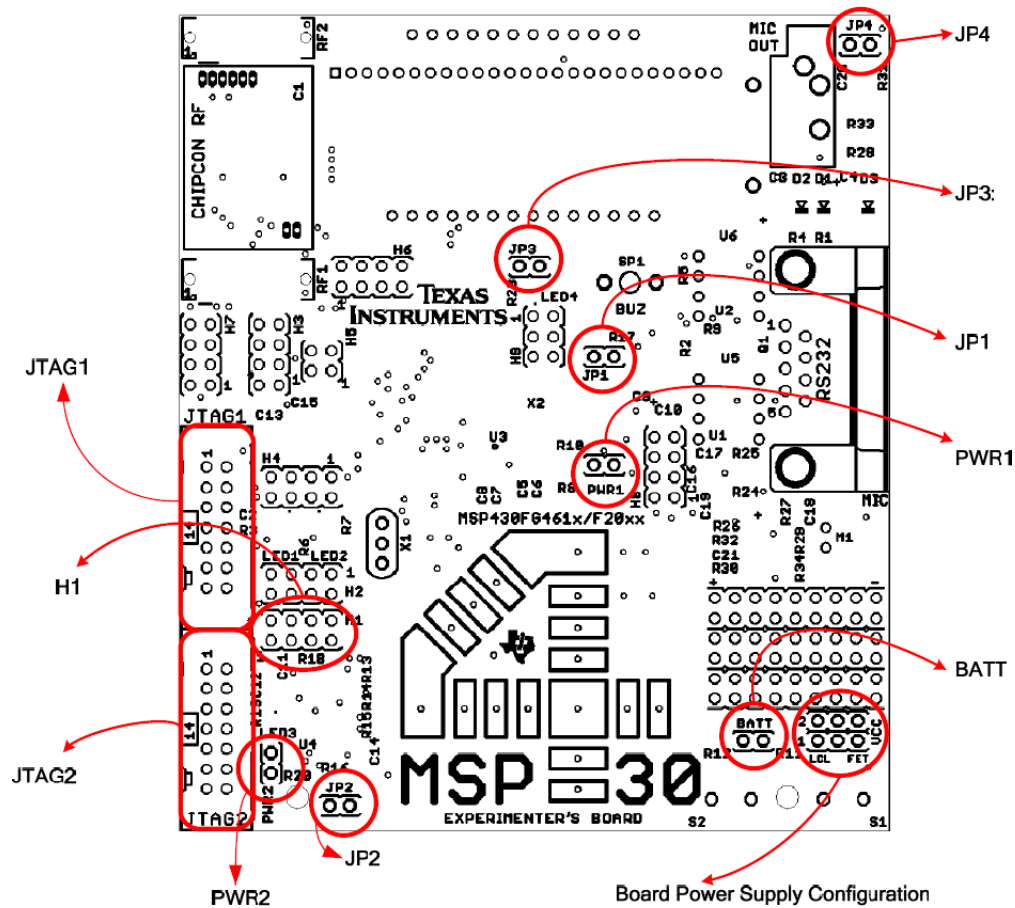

Figure 6. Jumper Locations

Table 1. Jumper Settings and Functionality

Header	Functionality When Jumper Present	Functionality When Jumper Absent	Requirement
PWR1	Provides power to MSP430FG4618. Also used to measure current consumption of the MSP430FG4618.	MSP430FG4618 is not powered	Required to use MSP430FG4618
PWR2	Provides power to MSP430F2013. Also used to measure current consumption of the MSP430F2013.	MSP430F2013 is not powered	Required to use MSP430F2013
BATT	Onboard batteries provide power. Also used to measure current consumption.	Batteries do not provide power to either MSP430 MCU	Required to use AAA batteries
JP1	Buzzer enabled and connected to P3.5 of the MSP430FG4618.	Buzzer muted	Optional
JP2	LED3 enabled and connected to P1.0 of the MSP430F2013.	LED3 connection disabled	Required to use LED3
JP3	LED4 enabled and connected to P5.1 of MSP430FG4618.	LED4 connection disabled	Required to use LED4
JP4	Attenuation set to approximately 69% of the DAC12 audio output.	98% attenuation of the DAC12 audio output	Optional
Header H1 (Pins 1-2, 3-4)	I²C Configuration 1-2: SDA – UCB0SDA 3-4: SCL – UCB0SCL	No communication possible through I ² C	Required to use I ² C
Header H1 (Pins 1-2, 3-4, 5-6, 7-8)	SPI Configuration 1-2: SDI – UCB0SIMO 3-4: SDO – UCB0SOMI 5-6: P1.4 – P3.0 (CS) 7-8: SCLK – UCB0CLK	No communication possible through SPI	Required to use SPI

7 Frequently Asked Questions

1. What devices can be programmed with the experimenter board?

The experimenter board is designed to develop applications using the MSP430FG4618 and MSP430F2013. These devices can be replaced by MSP430FG461x and MSP430F20xx device derivatives, respectively.

2. How is power supplied to the experimenter board?

Three supply options exist: 2xAAA battery power, JTAG and external power supplies are supported.

3. Can I use the Parallel FET (MSP-FET430PIF) to program and debug the MSP430 MCUs?

The MSP4304618 supports the USB FET (MSP-FET430UIF) and parallel port FET (MSP-FET430PIF). The MSP430F2013 is supported by the USB FET (MSP-FET430UIF) only. The parallel port FET does not support the Spy Bi-Wire program and debug mode used.

NOTE: The [MSP MCU Programmer and Debugger \(MSP-FET\)](#) supersedes both the MSP-FET430UIF and MSP-FET430PIF.

4. I have erased and reprogrammed the MSP430 MCU. Can I restore the factory-programmed firmware on the device?

The software source files are available in [MSP430Ware for MSP Microcontrollers](#).

5. The MSP430FG4618 is no longer accessible through JTAG, is something wrong with the device?

- Verify that the target device is powered properly
- If the target is powered locally, verify Vcc is applied to pin 4 of the JTAG header
- If communication and power are correctly applied to the target and the issue persists, it may be due to the MSP430FG4618 accidentally being programmed with MSP430F2xx source code. In some conditions 'F2xx source code loaded onto the FG4618 can configure the SVS module to monitor SVSIN (P6.7) and reset the device in case of a low voltage condition externally applied. Temporarily connecting P6.7 of the FG4618 to Vcc and reprogramming the target device with the valid source code will eliminate this issue.

6. Does the experimenter board protect against blowing the JTAG fuse of the target devices?

No. Fuse blow capability is inherent to all Flash-based MSP430 devices in order to protect user's intellectual property. Care must be taken to avoid the enabling of the fuse blow option during programming that would prevent further access to the MSP430 device(s) through JTAG.

7. I am measuring system current in the range of 30mA, is this normal?

Current consumption of the system is dependent on the functions and operation of the hardware being performed. The RF connectivity and isolated UART communication support, when used, can reach these current consumption levels. Take care that these elements are not accidentally enabled, specifically the isolated UART, if such system currents are not expected.

8. Can I use two FETs to perform simultaneous access of the FG4618 and F2013 during program/debug?

Yes, independent flash emulation tools (either USB or Parallel for FG4618 and USB only for F2013) can be simultaneously used to program the MSP430 target devices. When supplying power from the FET, it is recommended to use only one FET to source power. The second FET can sense this voltage level instead of supplying power, to avoid any voltage conflicts in-system. See [Section 5](#) for details regarding supported power supply configurations.

9. I cannot properly open the workspace and projects provided in the .zip file with IAR, how can I open the sample code?

The IAR workspace/projects included for the sample code provided has been created using IAR Embedded Workbench Version 3.42A. These projects are not backward compatible with older IAR releases and will not open using prior versions. New workspace/projects can be created and the sample code source files can be added manually in order to build these samples with older versions. Instruction for setting up a project in IAR are described in the [IAR Embedded Workbench IDE Version 7+ for MSP430 MCUs](#).

10. I have loaded the FG4618 and F2013 sample code for the capacitive touch sensing application. It doesn't seem to be working. What is wrong?

Verify that the correct jumper settings are used for H1 enabling the I²C communication link between MSP430s. Make sure jumper JP2 is removed, disconnecting LED3 from the touchpad circuitry. When connected, the LED causes the measurement of the capacitive touch element on P1.0 to fail.

9 References

1. [MSP430x4xx Family User's Guide](#)
2. [MSP430x2xx Family User's Guide](#)
3. [MSP430FG461x, MSP430CG461x Mixed-Signal Microcontrollers](#)
4. [MSP430F20x1, MSP430F20x2, MSP430F20x3 Mixed-Signal Microcontrollers](#)
5. [IAR Embedded Workbench IDE Version 7+ for MSP430 MCUs](#)
6. [MSP430 Interface to CC1100/2500 Code Library](#)

Revision History

NOTE: Page numbers for previous revisions may differ from page numbers in the current version.

Changes from October 3, 2007 to August 27, 2018	Page
• Editorial and format changes throughout document	1
• Changed the recommended FET to the MSP-FET	3
• Changed links to download software to MSP430Ware.....	3
• Updated link for software download and noted obsolete tools in Section 6.2.1 , <i>Wireless Evaluation Module Interface</i>	5
• Moved former Appendix B to Section 6.5.1 , <i>Jumper Locations and Settings</i>	8
• Deleted former Appendix A, <i>Configuring an IAR Embedded Workbench Project</i>	12

STANDARD TERMS FOR EVALUATION MODULES

1. *Delivery:* TI delivers TI evaluation boards, kits, or modules, including any accompanying demonstration software, components, and/or documentation which may be provided together or separately (collectively, an "EVM" or "EVMs") to the User ("User") in accordance with the terms set forth herein. User's acceptance of the EVM is expressly subject to the following terms.
 - 1.1 EVMs are intended solely for product or software developers for use in a research and development setting to facilitate feasibility evaluation, experimentation, or scientific analysis of TI semiconductor products. EVMs have no direct function and are not finished products. EVMs shall not be directly or indirectly assembled as a part or subassembly in any finished product. For clarification, any software or software tools provided with the EVM ("Software") shall not be subject to the terms and conditions set forth herein but rather shall be subject to the applicable terms that accompany such Software
 - 1.2 EVMs are not intended for consumer or household use. EVMs may not be sold, sublicensed, leased, rented, loaned, assigned, or otherwise distributed for commercial purposes by Users, in whole or in part, or used in any finished product or production system.
2. *Limited Warranty and Related Remedies/Disclaimers:*
 - 2.1 These terms do not apply to Software. The warranty, if any, for Software is covered in the applicable Software License Agreement.
 - 2.2 TI warrants that the TI EVM will conform to TI's published specifications for ninety (90) days after the date TI delivers such EVM to User. Notwithstanding the foregoing, TI shall not be liable for a nonconforming EVM if (a) the nonconformity was caused by neglect, misuse or mistreatment by an entity other than TI, including improper installation or testing, or for any EVMs that have been altered or modified in any way by an entity other than TI, (b) the nonconformity resulted from User's design, specifications or instructions for such EVMs or improper system design, or (c) User has not paid on time. Testing and other quality control techniques are used to the extent TI deems necessary. TI does not test all parameters of each EVM. User's claims against TI under this Section 2 are void if User fails to notify TI of any apparent defects in the EVMs within ten (10) business days after delivery, or of any hidden defects with ten (10) business days after the defect has been detected.
 - 2.3 TI's sole liability shall be at its option to repair or replace EVMs that fail to conform to the warranty set forth above, or credit User's account for such EVM. TI's liability under this warranty shall be limited to EVMs that are returned during the warranty period to the address designated by TI and that are determined by TI not to conform to such warranty. If TI elects to repair or replace such EVM, TI shall have a reasonable time to repair such EVM or provide replacements. Repaired EVMs shall be warranted for the remainder of the original warranty period. Replaced EVMs shall be warranted for a new full ninety (90) day warranty period.
3. *Regulatory Notices:*
 - 3.1 *United States*
 - 3.1.1 *Notice applicable to EVMs not FCC-Approved:*

FCC NOTICE: This kit is designed to allow product developers to evaluate electronic components, circuitry, or software associated with the kit to determine whether to incorporate such items in a finished product and software developers to write software applications for use with the end product. This kit is not a finished product and when assembled may not be resold or otherwise marketed unless all required FCC equipment authorizations are first obtained. Operation is subject to the condition that this product not cause harmful interference to licensed radio stations and that this product accept harmful interference. Unless the assembled kit is designed to operate under part 15, part 18 or part 95 of this chapter, the operator of the kit must operate under the authority of an FCC license holder or must secure an experimental authorization under part 5 of this chapter.
 - 3.1.2 *For EVMs annotated as FCC – FEDERAL COMMUNICATIONS COMMISSION Part 15 Compliant:*

CAUTION

This device complies with part 15 of the FCC Rules. Operation is subject to the following two conditions: (1) This device may not cause harmful interference, and (2) this device must accept any interference received, including interference that may cause undesired operation.

Changes or modifications not expressly approved by the party responsible for compliance could void the user's authority to operate the equipment.

FCC Interference Statement for Class A EVM devices

NOTE: This equipment has been tested and found to comply with the limits for a Class A digital device, pursuant to part 15 of the FCC Rules. These limits are designed to provide reasonable protection against harmful interference when the equipment is operated in a commercial environment. This equipment generates, uses, and can radiate radio frequency energy and, if not installed and used in accordance with the instruction manual, may cause harmful interference to radio communications. Operation of this equipment in a residential area is likely to cause harmful interference in which case the user will be required to correct the interference at his own expense.

FCC Interference Statement for Class B EVM devices

NOTE: This equipment has been tested and found to comply with the limits for a Class B digital device, pursuant to part 15 of the FCC Rules. These limits are designed to provide reasonable protection against harmful interference in a residential installation. This equipment generates, uses and can radiate radio frequency energy and, if not installed and used in accordance with the instructions, may cause harmful interference to radio communications. However, there is no guarantee that interference will not occur in a particular installation. If this equipment does cause harmful interference to radio or television reception, which can be determined by turning the equipment off and on, the user is encouraged to try to correct the interference by one or more of the following measures:

- Reorient or relocate the receiving antenna.
- Increase the separation between the equipment and receiver.
- Connect the equipment into an outlet on a circuit different from that to which the receiver is connected.
- Consult the dealer or an experienced radio/TV technician for help.

3.2 Canada

3.2.1 For EVMs issued with an Industry Canada Certificate of Conformance to RSS-210 or RSS-247

Concerning EVMs Including Radio Transmitters:

This device complies with Industry Canada license-exempt RSSs. Operation is subject to the following two conditions:

(1) this device may not cause interference, and (2) this device must accept any interference, including interference that may cause undesired operation of the device.

Concernant les EVMs avec appareils radio:

Le présent appareil est conforme aux CNR d'Industrie Canada applicables aux appareils radio exempts de licence. L'exploitation est autorisée aux deux conditions suivantes: (1) l'appareil ne doit pas produire de brouillage, et (2) l'utilisateur de l'appareil doit accepter tout brouillage radioélectrique subi, même si le brouillage est susceptible d'en compromettre le fonctionnement.

Concerning EVMs Including Detachable Antennas:

Under Industry Canada regulations, this radio transmitter may only operate using an antenna of a type and maximum (or lesser) gain approved for the transmitter by Industry Canada. To reduce potential radio interference to other users, the antenna type and its gain should be so chosen that the equivalent isotropically radiated power (e.i.r.p.) is not more than that necessary for successful communication. This radio transmitter has been approved by Industry Canada to operate with the antenna types listed in the user guide with the maximum permissible gain and required antenna impedance for each antenna type indicated. Antenna types not included in this list, having a gain greater than the maximum gain indicated for that type, are strictly prohibited for use with this device.

Concernant les EVMs avec antennes détachables

Conformément à la réglementation d'Industrie Canada, le présent émetteur radio peut fonctionner avec une antenne d'un type et d'un gain maximal (ou inférieur) approuvé pour l'émetteur par Industrie Canada. Dans le but de réduire les risques de brouillage radioélectrique à l'intention des autres utilisateurs, il faut choisir le type d'antenne et son gain de sorte que la puissance isotrope rayonnée équivalente (p.i.r.e.) ne dépasse pas l'intensité nécessaire à l'établissement d'une communication satisfaisante. Le présent émetteur radio a été approuvé par Industrie Canada pour fonctionner avec les types d'antenne énumérés dans le manuel d'usage et ayant un gain admissible maximal et l'impédance requise pour chaque type d'antenne. Les types d'antenne non inclus dans cette liste, ou dont le gain est supérieur au gain maximal indiqué, sont strictement interdits pour l'exploitation de l'émetteur.

3.3 Japan

3.3.1 *Notice for EVMs delivered in Japan:* Please see http://www.tij.co.jp/lstds/ti_ja/general/eStore/notice_01.page 日本国内に輸入される評価用キット、ボードについては、次のところをご覧ください。
http://www.tij.co.jp/lstds/ti_ja/general/eStore/notice_01.page

3.3.2 *Notice for Users of EVMs Considered "Radio Frequency Products" in Japan:* EVMs entering Japan may not be certified by TI as conforming to Technical Regulations of Radio Law of Japan.

If User uses EVMs in Japan, not certified to Technical Regulations of Radio Law of Japan, User is required to follow the instructions set forth by Radio Law of Japan, which includes, but is not limited to, the instructions below with respect to EVMs (which for the avoidance of doubt are stated strictly for convenience and should be verified by User):

1. Use EVMs in a shielded room or any other test facility as defined in the notification #173 issued by Ministry of Internal Affairs and Communications on March 28, 2006, based on Sub-section 1.1 of Article 6 of the Ministry's Rule for Enforcement of Radio Law of Japan,
2. Use EVMs only after User obtains the license of Test Radio Station as provided in Radio Law of Japan with respect to EVMs, or
3. Use of EVMs only after User obtains the Technical Regulations Conformity Certification as provided in Radio Law of Japan with respect to EVMs. Also, do not transfer EVMs, unless User gives the same notice above to the transferee. Please note that if User does not follow the instructions above, User will be subject to penalties of Radio Law of Japan.

【無線電波を送信する製品の開発キットをお使いになる際の注意事項】 開発キットの中には技術基準適合証明を受けていないものがあります。技術適合証明を受けていないものご使用に際しては、電波法遵守のため、以下のいずれかの措置を取っていただく必要がありますのでご注意ください。

1. 電波法施行規則第6条第1項第1号に基づく平成18年3月28日総務省告示第173号で定められた電波暗室等の試験設備でご使用いただく。
2. 実験局の免許を取得後ご使用いただく。
3. 技術基準適合証明を取得後ご使用いただく。

なお、本製品は、上記の「ご使用にあたっての注意」を譲渡先、移転先に通知しない限り、譲渡、移転できないものとします。

上記を遵守頂けない場合は、電波法の罰則が適用される可能性があることをご留意ください。日本テキサス・インスツルメンツ株式会社

東京都新宿区西新宿 6 丁目 2 4 番 1 号
西新宿三井ビル

3.3.3 *Notice for EVMs for Power Line Communication:* Please see http://www.tij.co.jp/llds/ti_ja/general/eStore/notice_02.page
電力線搬送波通信についての開発キットをお使いになる際の注意事項については、次のところをご覧ください。 http://www.tij.co.jp/llds/ti_ja/general/eStore/notice_02.page

3.4 *European Union*

3.4.1 *For EVMs subject to EU Directive 2014/30/EU (Electromagnetic Compatibility Directive):*

This is a class A product intended for use in environments other than domestic environments that are connected to a low-voltage power-supply network that supplies buildings used for domestic purposes. In a domestic environment this product may cause radio interference in which case the user may be required to take adequate measures.

4 *EVM Use Restrictions and Warnings:*

4.1 EVMS ARE NOT FOR USE IN FUNCTIONAL SAFETY AND/OR SAFETY CRITICAL EVALUATIONS, INCLUDING BUT NOT LIMITED TO EVALUATIONS OF LIFE SUPPORT APPLICATIONS.

4.2 User must read and apply the user guide and other available documentation provided by TI regarding the EVM prior to handling or using the EVM, including without limitation any warning or restriction notices. The notices contain important safety information related to, for example, temperatures and voltages.

4.3 *Safety-Related Warnings and Restrictions:*

4.3.1 User shall operate the EVM within TI's recommended specifications and environmental considerations stated in the user guide, other available documentation provided by TI, and any other applicable requirements and employ reasonable and customary safeguards. Exceeding the specified performance ratings and specifications (including but not limited to input and output voltage, current, power, and environmental ranges) for the EVM may cause personal injury or death, or property damage. If there are questions concerning performance ratings and specifications, User should contact a TI field representative prior to connecting interface electronics including input power and intended loads. Any loads applied outside of the specified output range may also result in unintended and/or inaccurate operation and/or possible permanent damage to the EVM and/or interface electronics. Please consult the EVM user guide prior to connecting any load to the EVM output. If there is uncertainty as to the load specification, please contact a TI field representative. During normal operation, even with the inputs and outputs kept within the specified allowable ranges, some circuit components may have elevated case temperatures. These components include but are not limited to linear regulators, switching transistors, pass transistors, current sense resistors, and heat sinks, which can be identified using the information in the associated documentation. When working with the EVM, please be aware that the EVM may become very warm.

4.3.2 EVMs are intended solely for use by technically qualified, professional electronics experts who are familiar with the dangers and application risks associated with handling electrical mechanical components, systems, and subsystems. User assumes all responsibility and liability for proper and safe handling and use of the EVM by User or its employees, affiliates, contractors or designees. User assumes all responsibility and liability to ensure that any interfaces (electronic and/or mechanical) between the EVM and any human body are designed with suitable isolation and means to safely limit accessible leakage currents to minimize the risk of electrical shock hazard. User assumes all responsibility and liability for any improper or unsafe handling or use of the EVM by User or its employees, affiliates, contractors or designees.

4.4 User assumes all responsibility and liability to determine whether the EVM is subject to any applicable international, federal, state, or local laws and regulations related to User's handling and use of the EVM and, if applicable, User assumes all responsibility and liability for compliance in all respects with such laws and regulations. User assumes all responsibility and liability for proper disposal and recycling of the EVM consistent with all applicable international, federal, state, and local requirements.

5. *Accuracy of Information:* To the extent TI provides information on the availability and function of EVMs, TI attempts to be as accurate as possible. However, TI does not warrant the accuracy of EVM descriptions, EVM availability or other information on its websites as accurate, complete, reliable, current, or error-free.

6. *Disclaimers:*
- 6.1 EXCEPT AS SET FORTH ABOVE, EVMS AND ANY MATERIALS PROVIDED WITH THE EVM (INCLUDING, BUT NOT LIMITED TO, REFERENCE DESIGNS AND THE DESIGN OF THE EVM ITSELF) ARE PROVIDED "AS IS" AND "WITH ALL FAULTS." TI DISCLAIMS ALL OTHER WARRANTIES, EXPRESS OR IMPLIED, REGARDING SUCH ITEMS, INCLUDING BUT NOT LIMITED TO ANY EPIDEMIC FAILURE WARRANTY OR IMPLIED WARRANTIES OF MERCHANTABILITY OR FITNESS FOR A PARTICULAR PURPOSE OR NON-INFRINGEMENT OF ANY THIRD PARTY PATENTS, COPYRIGHTS, TRADE SECRETS OR OTHER INTELLECTUAL PROPERTY RIGHTS.
- 6.2 EXCEPT FOR THE LIMITED RIGHT TO USE THE EVM SET FORTH HEREIN, NOTHING IN THESE TERMS SHALL BE CONSTRUED AS GRANTING OR CONFERRING ANY RIGHTS BY LICENSE, PATENT, OR ANY OTHER INDUSTRIAL OR INTELLECTUAL PROPERTY RIGHT OF TI, ITS SUPPLIERS/LICENSORS OR ANY OTHER THIRD PARTY, TO USE THE EVM IN ANY FINISHED END-USER OR READY-TO-USE FINAL PRODUCT, OR FOR ANY INVENTION, DISCOVERY OR IMPROVEMENT, REGARDLESS OF WHEN MADE, CONCEIVED OR ACQUIRED.
7. *USER'S INDEMNITY OBLIGATIONS AND REPRESENTATIONS.* USER WILL DEFEND, INDEMNIFY AND HOLD TI, ITS LICENSORS AND THEIR REPRESENTATIVES HARMLESS FROM AND AGAINST ANY AND ALL CLAIMS, DAMAGES, LOSSES, EXPENSES, COSTS AND LIABILITIES (COLLECTIVELY, "CLAIMS") ARISING OUT OF OR IN CONNECTION WITH ANY HANDLING OR USE OF THE EVM THAT IS NOT IN ACCORDANCE WITH THESE TERMS. THIS OBLIGATION SHALL APPLY WHETHER CLAIMS ARISE UNDER STATUTE, REGULATION, OR THE LAW OF TORT, CONTRACT OR ANY OTHER LEGAL THEORY, AND EVEN IF THE EVM FAILS TO PERFORM AS DESCRIBED OR EXPECTED.
8. *Limitations on Damages and Liability:*
- 8.1 *General Limitations.* IN NO EVENT SHALL TI BE LIABLE FOR ANY SPECIAL, COLLATERAL, INDIRECT, PUNITIVE, INCIDENTAL, CONSEQUENTIAL, OR EXEMPLARY DAMAGES IN CONNECTION WITH OR ARISING OUT OF THESE TERMS OR THE USE OF THE EVMS , REGARDLESS OF WHETHER TI HAS BEEN ADVISED OF THE POSSIBILITY OF SUCH DAMAGES. EXCLUDED DAMAGES INCLUDE, BUT ARE NOT LIMITED TO, COST OF REMOVAL OR REINSTALLATION, ANCILLARY COSTS TO THE PROCUREMENT OF SUBSTITUTE GOODS OR SERVICES, RETESTING, OUTSIDE COMPUTER TIME, LABOR COSTS, LOSS OF GOODWILL, LOSS OF PROFITS, LOSS OF SAVINGS, LOSS OF USE, LOSS OF DATA, OR BUSINESS INTERRUPTION. NO CLAIM, SUIT OR ACTION SHALL BE BROUGHT AGAINST TI MORE THAN TWELVE (12) MONTHS AFTER THE EVENT THAT GAVE RISE TO THE CAUSE OF ACTION HAS OCCURRED.
- 8.2 *Specific Limitations.* IN NO EVENT SHALL TI'S AGGREGATE LIABILITY FROM ANY USE OF AN EVM PROVIDED HEREUNDER, INCLUDING FROM ANY WARRANTY, INDEMNITY OR OTHER OBLIGATION ARISING OUT OF OR IN CONNECTION WITH THESE TERMS, , EXCEED THE TOTAL AMOUNT PAID TO TI BY USER FOR THE PARTICULAR EVM(S) AT ISSUE DURING THE PRIOR TWELVE (12) MONTHS WITH RESPECT TO WHICH LOSSES OR DAMAGES ARE CLAIMED. THE EXISTENCE OF MORE THAN ONE CLAIM SHALL NOT ENLARGE OR EXTEND THIS LIMIT.
9. *Return Policy.* Except as otherwise provided, TI does not offer any refunds, returns, or exchanges. Furthermore, no return of EVM(s) will be accepted if the package has been opened and no return of the EVM(s) will be accepted if they are damaged or otherwise not in a resalable condition. If User feels it has been incorrectly charged for the EVM(s) it ordered or that delivery violates the applicable order, User should contact TI. All refunds will be made in full within thirty (30) working days from the return of the components(s), excluding any postage or packaging costs.
10. *Governing Law:* These terms and conditions shall be governed by and interpreted in accordance with the laws of the State of Texas, without reference to conflict-of-laws principles. User agrees that non-exclusive jurisdiction for any dispute arising out of or relating to these terms and conditions lies within courts located in the State of Texas and consents to venue in Dallas County, Texas. Notwithstanding the foregoing, any judgment may be enforced in any United States or foreign court, and TI may seek injunctive relief in any United States or foreign court.

IMPORTANT NOTICE FOR TI DESIGN INFORMATION AND RESOURCES

Texas Instruments Incorporated ("TI") technical, application or other design advice, services or information, including, but not limited to, reference designs and materials relating to evaluation modules, (collectively, "TI Resources") are intended to assist designers who are developing applications that incorporate TI products; by downloading, accessing or using any particular TI Resource in any way, you (individually or, if you are acting on behalf of a company, your company) agree to use it solely for this purpose and subject to the terms of this Notice.

TI's provision of TI Resources does not expand or otherwise alter TI's applicable published warranties or warranty disclaimers for TI products, and no additional obligations or liabilities arise from TI providing such TI Resources. TI reserves the right to make corrections, enhancements, improvements and other changes to its TI Resources.

You understand and agree that you remain responsible for using your independent analysis, evaluation and judgment in designing your applications and that you have full and exclusive responsibility to assure the safety of your applications and compliance of your applications (and of all TI products used in or for your applications) with all applicable regulations, laws and other applicable requirements. You represent that, with respect to your applications, you have all the necessary expertise to create and implement safeguards that (1) anticipate dangerous consequences of failures, (2) monitor failures and their consequences, and (3) lessen the likelihood of failures that might cause harm and take appropriate actions. You agree that prior to using or distributing any applications that include TI products, you will thoroughly test such applications and the functionality of such TI products as used in such applications. TI has not conducted any testing other than that specifically described in the published documentation for a particular TI Resource.

You are authorized to use, copy and modify any individual TI Resource only in connection with the development of applications that include the TI product(s) identified in such TI Resource. NO OTHER LICENSE, EXPRESS OR IMPLIED, BY ESTOPPEL OR OTHERWISE TO ANY OTHER TI INTELLECTUAL PROPERTY RIGHT, AND NO LICENSE TO ANY TECHNOLOGY OR INTELLECTUAL PROPERTY RIGHT OF TI OR ANY THIRD PARTY IS GRANTED HEREIN, including but not limited to any patent right, copyright, mask work right, or other intellectual property right relating to any combination, machine, or process in which TI products or services are used. Information regarding or referencing third-party products or services does not constitute a license to use such products or services, or a warranty or endorsement thereof. Use of TI Resources may require a license from a third party under the patents or other intellectual property of the third party, or a license from TI under the patents or other intellectual property of TI.

TI RESOURCES ARE PROVIDED "AS IS" AND WITH ALL FAULTS. TI DISCLAIMS ALL OTHER WARRANTIES OR REPRESENTATIONS, EXPRESS OR IMPLIED, REGARDING TI RESOURCES OR USE THEREOF, INCLUDING BUT NOT LIMITED TO ACCURACY OR COMPLETENESS, TITLE, ANY EPIDEMIC FAILURE WARRANTY AND ANY IMPLIED WARRANTIES OF MERCHANTABILITY, FITNESS FOR A PARTICULAR PURPOSE, AND NON-INFRINGEMENT OF ANY THIRD PARTY INTELLECTUAL PROPERTY RIGHTS.

TI SHALL NOT BE LIABLE FOR AND SHALL NOT DEFEND OR INDEMNIFY YOU AGAINST ANY CLAIM, INCLUDING BUT NOT LIMITED TO ANY INFRINGEMENT CLAIM THAT RELATES TO OR IS BASED ON ANY COMBINATION OF PRODUCTS EVEN IF DESCRIBED IN TI RESOURCES OR OTHERWISE. IN NO EVENT SHALL TI BE LIABLE FOR ANY ACTUAL, DIRECT, SPECIAL, COLLATERAL, INDIRECT, PUNITIVE, INCIDENTAL, CONSEQUENTIAL OR EXEMPLARY DAMAGES IN CONNECTION WITH OR ARISING OUT OF TI RESOURCES OR USE THEREOF, AND REGARDLESS OF WHETHER TI HAS BEEN ADVISED OF THE POSSIBILITY OF SUCH DAMAGES.

You agree to fully indemnify TI and its representatives against any damages, costs, losses, and/or liabilities arising out of your non-compliance with the terms and provisions of this Notice.

This Notice applies to TI Resources. Additional terms apply to the use and purchase of certain types of materials, TI products and services. These include; without limitation, TI's standard terms for semiconductor products (<http://www.ti.com/sc/docs/stdterms.htm>), [evaluation modules](#), and [samples](http://www.ti.com/sc/docs/sampterm.htm) (<http://www.ti.com/sc/docs/sampterm.htm>).

Mailing Address: Texas Instruments, Post Office Box 655303, Dallas, Texas 75265
Copyright © 2018, Texas Instruments Incorporated