

Evaluating the **ADM3056E** 5.7 kV RMS, Signal Isolated, CAN FD Transceiver

FEATURES

- ADM3056E** 12 Mbps isolated CAN FD transceiver
- On-board LDOs for 6 V to 9 V supply, providing 5 V to the **ADM3056E** V_{DD1} pin and V_{DD2} pin
- Screw terminal connectors for the following
 - 6 V to 9 V LDO, 5 V power supply to the V_{DD1} pin
 - 1.7 V to 5.5 V direct power supply to V_{DD1} pin
 - 6 V to 9 V LDO, 5 V power supply to the V_{DD2} pin
 - 4.5 V to 5.5 V direct power supply to V_{DD2} pin
 - TXD pin, RXD pin, STBY pin, SILENT pin, AUX_{IN} pin, AUX_{OUT} pin, RS pin, CANH pin, and CANL pin signals
- Divided PCB power and return planes
- SMA connectors for TXD pin and RXD pin signals

EVALUATION KIT CONTENTS

- EVAL-ADM3056EEBZ evaluation board
- ADM3056EBRIZ**
- ADP7104**
- LTC6900**

DOCUMENTS NEEDED

- ADM3056E** data sheet

GENERAL DESCRIPTION

The EVAL-ADM3056EEBZ evaluation board allows the user to evaluate the **ADM3056E** signal isolated transceiver for controller area network (CAN) or CAN with flexible data rate (CAN FD) networks. The EVAL-ADM3056EEBZ allows all of the input and output functions to work without the need for external components.

Based on the Analog Devices, Inc., iCoupler® technology, the **ADM3056E** integrates logic side on-off keying (OOK) signal isolation channels and a 12 Mbps CAN FD transceiver.

The EVAL-ADM3056EEBZ comes populated with the **ADM3056E**.

Full specifications of the **ADM3056E** can be found in the **ADM3056E** data sheet, and must be consulted in conjunction with this user guide when using the EVAL-ADM3056EEBZ.

Refer to the **AN-1123 Application Note** for more information on CAN protocol implementation.

EVALUATION BOARD PHOTOGRAPH

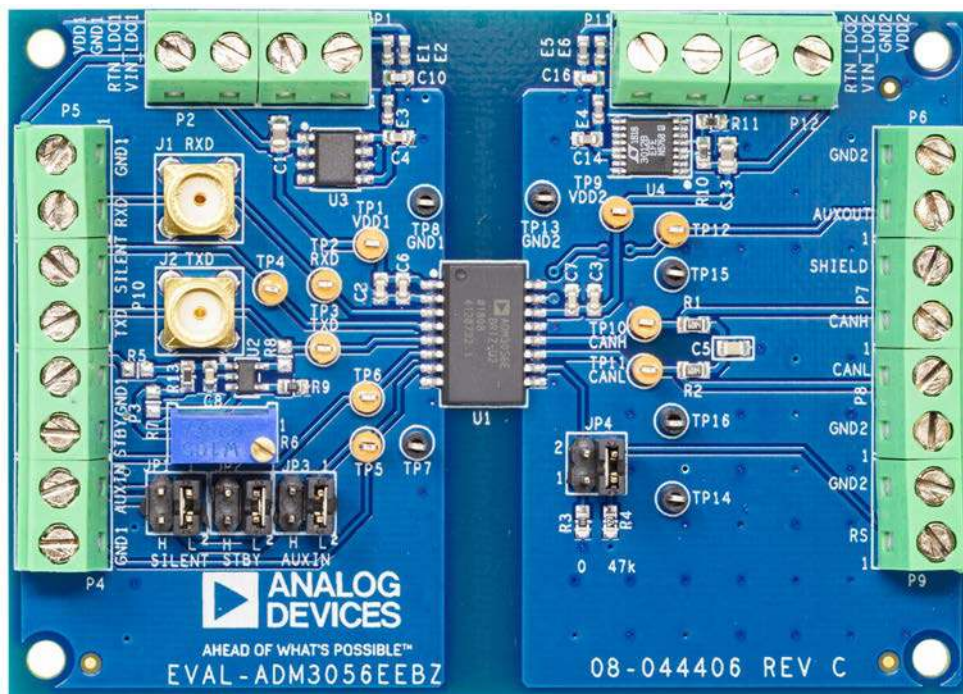

Figure 1.

TABLE OF CONTENTS

Features	1	Using the Evaluation Board	3
Evaluation Kit Contents.....	1	Printed Circuit Board (PCB) Layout Recommendations.....	3
Documents Needed.....	1	Evaluation Board Schematic and Artwork.....	4
General Description	1	Ordering Information.....	7
Evaluation Board Photograph.....	1	Bill of Materials.....	7
Revision History	2		
Evaluation Board Hardware.....	3		

REVISION HISTORY

12/2018—Revision 0: Initial Version

EVALUATION BOARD HARDWARE

USING THE EVALUATION BOARD

Figure 1 shows the EVAL-ADM3056EEBZ. The V_{DD1} and V_{DD2} supply pins of the [ADM3056E](#) device must be supplied with input power. The V_{DD1} pin and the V_{DD2} pin can be powered directly or through the fixed output 5 V on-board low dropout (LDO) regulators. The V_{DD1} side LDO input supply requires a power supply voltage of 6 V to 9 V and connects to Pin 1 of Screw Terminal P1 (marked VIN_LDO1 on the schematic) and Pin 2 of Screw Terminal P1 (marked RTN_LDO1 on the schematic). The V_{DD2} side LDO input supply also requires a power supply voltage of 6 V to 9 V but connects to Pin 1 of Screw Terminal P11 (marked VIN_LDO2 on the schematic) and Pin 2 of Screw Terminal P11 (marked RTN_LDO2 on the schematic).

Using the LDO regulator, the complete board can be powered by a 9 V battery (when testing for electromagnetic compatibility

(EMC), for example). The [ADP7104](#) LDO regulator and [LT3012](#) LDO regulator both feature reverse current protection and can be left unpowered but connected to the EVAL-ADM3050EEBZ evaluation board when supplying power directly to the [ADM3050E](#) V_{DD1} and V_{DD2} pins. Additionally, the [LT3012](#) is protected against reverse voltages to the input power pin. This [LT3012](#) feature can be used in conjunction with the [ADM3056E](#) device bus fault tolerance to protect against miswire damage in applications where the supply power and CAN bus pins are manually wired.

PRINTED CIRCUIT BOARD (PCB) LAYOUT RECOMENDATIONS

Place a 0.1 μF capacitor as close as possible to V_{DD1} and $GND1$ and another 0.1 μF capacitor as close as possible to V_{DD2} and $GND2$ as shown in the layout example for the EVAL-ADM3056EEBZ (see Figure 2).

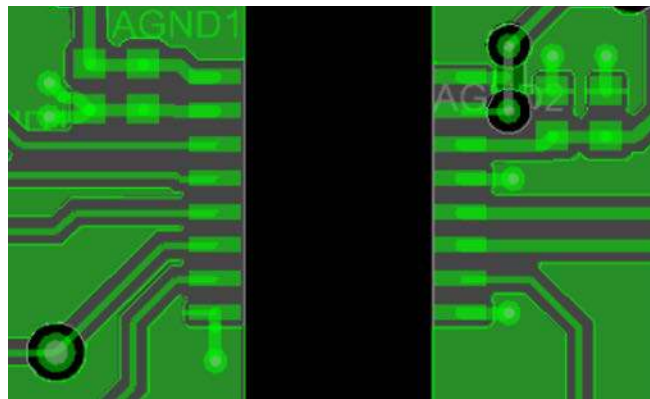
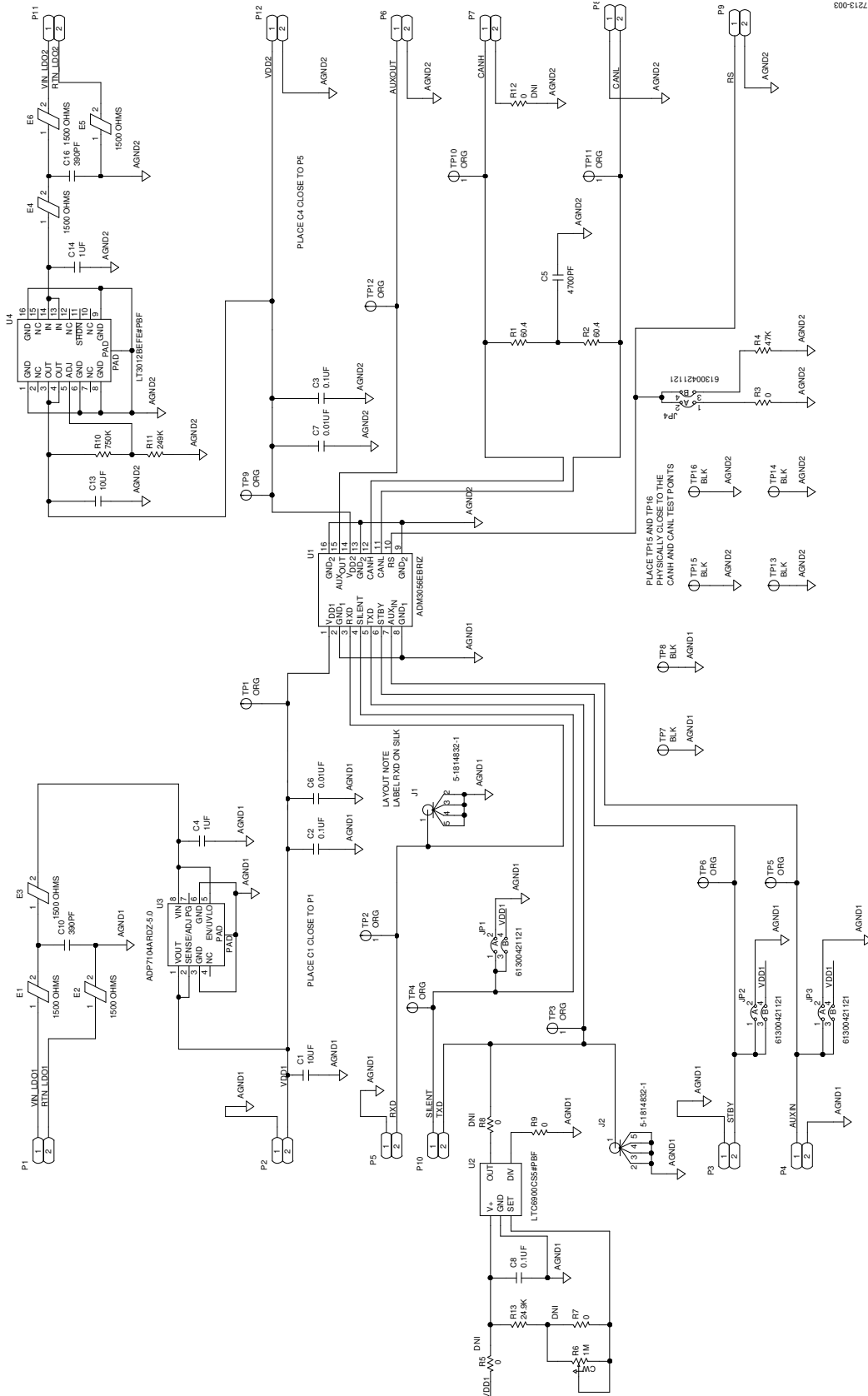

Figure 2. Layout Example for the EVAL-ADM3056EEBZ

EVALUATION BOARD SCHEMATIC AND ARTWORK



17219-003

Figure 3. EVAL-ADM3056EEBZ Schematic

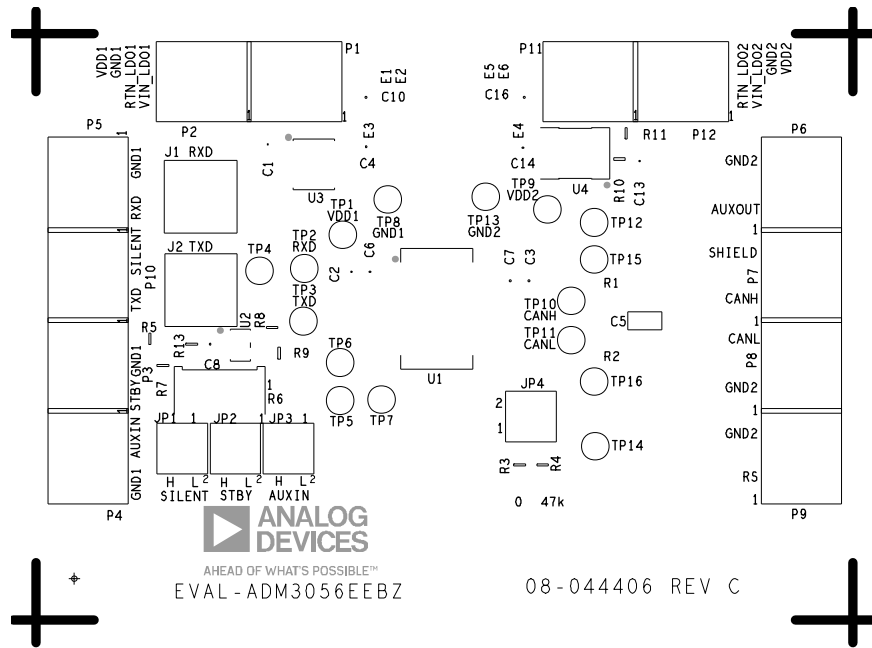

Figure 4. EVAL-ADM3056EBZ Primary Silkscreen

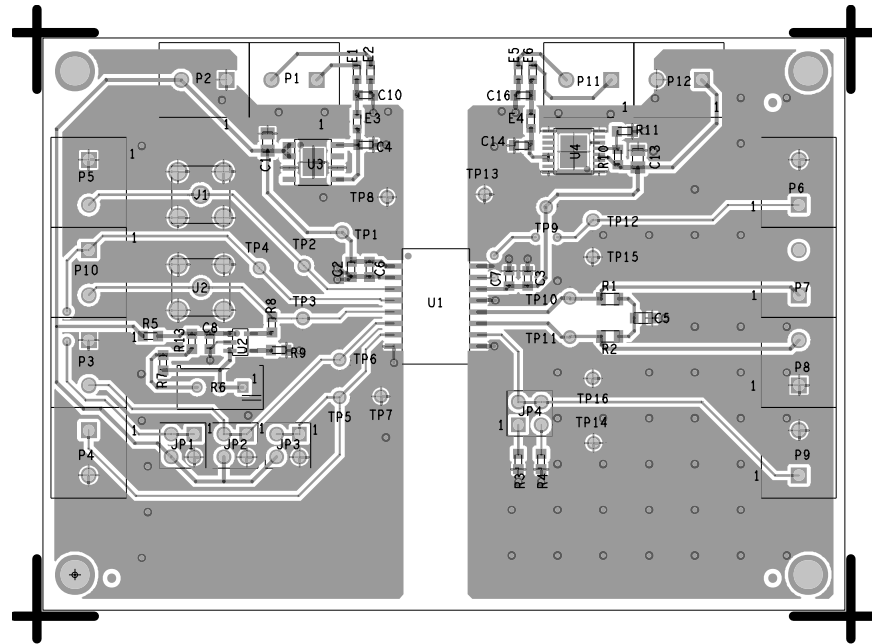
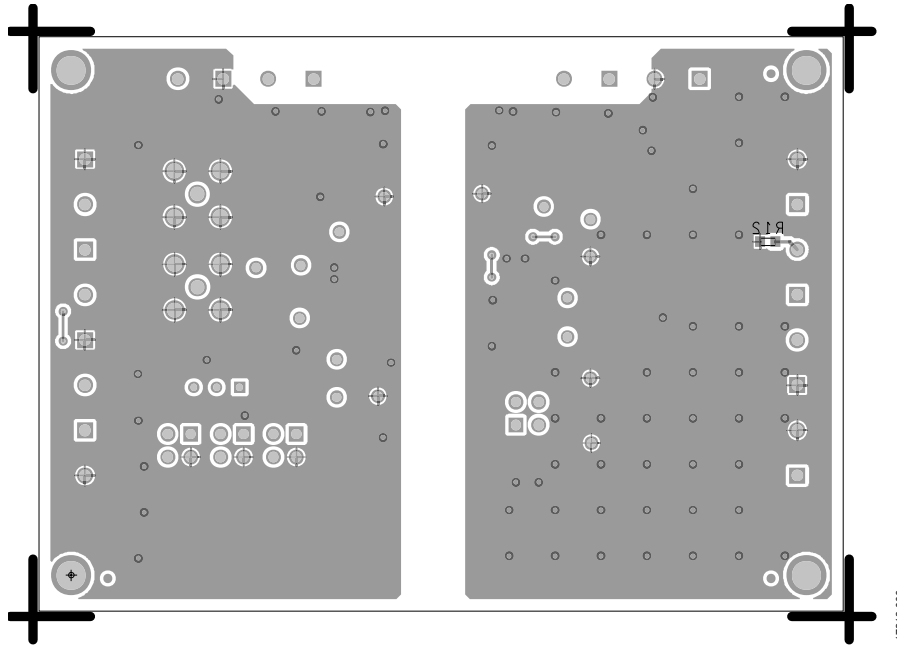
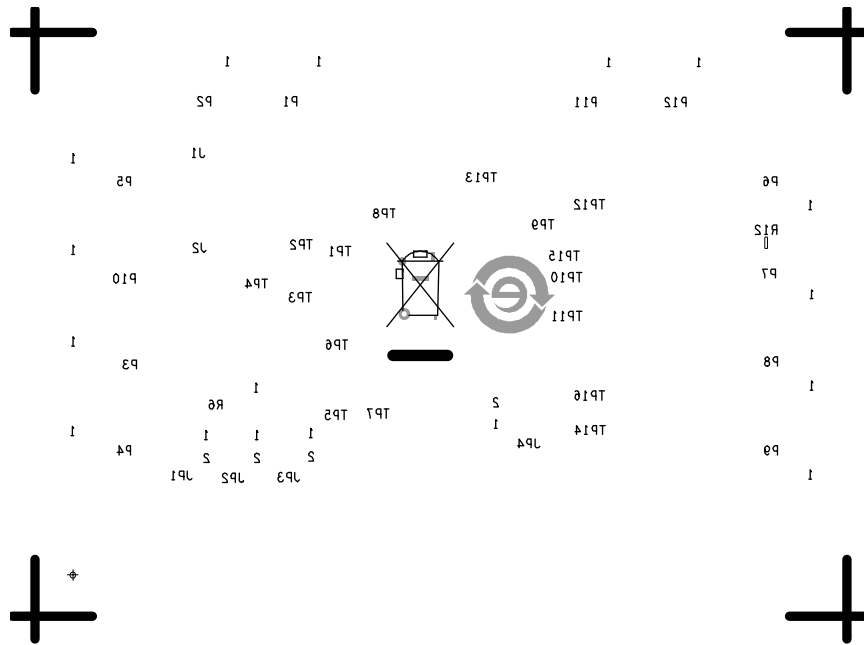

Figure 5. EVAL-ADM3056EBZ Top Layer



17213-006

Figure 6. EVAL-ADM3056EEBZ Bottom Layer



17213-007

Figure 7. EVAL-ADM3056EEBZ Bottom Silkscreen

ORDERING INFORMATION

BILL OF MATERIALS

Table 1.

Component	Description	Supplier	Part No.
U1	5.7 kV rms, signal isolated, CAN FD transceiver	Analog Devices	ADM3056EBRIZ
U2	Low power, resistor set oscillator, 1 kHz to 20 MHz	Analog Devices	LTC6900CS5#PBF
U3	Low noise, complementary metal-oxide semiconductor (CMOS), LDO, 5.0 V output voltage	Analog Devices	ADP7104ARDZ-5.0-R7
U4	LDO, micropower linear regulator	Analog Devices	LT3012EFE#PBF
C1, C13	Capacitors, 10 μ F, X7R, 0805	Würth Elektronik	885012207026
C10, C16	Capacitors, 390 pF, X7R, 0603	AVX	0603YC391KAT2A
C4, C14	Capacitors, 1 μ F, X7R, 0603	Würth Elektronik	885012206076
C2, C3, C8	Capacitors, 0.1 μ F, X7R, 0603	Würth Elektronik	885012206046
C5	Capacitors, 4700 pF, X7R, 0805	Würth Elektronik	885012207090
C6, C7	Capacitors, 0.01 μ F, X7R, 0603	Würth Elektronik	885012206014
E1, E2, E3, E4, E5, E6	Ferrite beads, 1500 Ω , 0603	Murata	BLM18HE152SN1D
J1, J2	Connectors, subminiature, Version A (SMA)	TE Connectivity	5-1814832-1
JP1, JP2, JP3, JP4	4-position headers	Würth Elektronik	61300421121
Not Applicable	Mechanical jumper	FCI	65474-001LF
P1, P2, P3, P4, P5, P6, P7, P8, P9, P10, P11, P12	Connectors, 2-position screw terminal block	Würth Elektronik	691 213 710 002
R1, R2	Resistors, 60.4 Ω , 1/8 W, 0805	Panasonic	ERJ-6ENF60R4V
R10	Resistor, 750 k Ω , 1/10 W, 0603	Panasonic	ERJ-3EKF7503V
R11	Resistor, 249 k Ω , 1/10 W, 0603	Panasonic	ERJ-3EKF2493V
R13	Resistor, 24.9 k Ω , 1/10 W, 0603	Panasonic	ERJ-3EKF2492V
R3, R9	Resistors, 0 Ω , 1/10 W, 0603	Panasonic	ERJ-3GEY0R00V
R4	Resistor, 47 k Ω , 1/10 W, 0603	Panasonic	ERJ-3EKF4702V
R6	Potentiometer, 1 M Ω	Bourns	3296W-1-105LF
TP1, TP2, TP3, TP4, TP5, TP6, TP9, TP10, TP11, TP12	Orange test points	Keystone	5003
TP7, TP8, TP13, TP14, TP15, TP16	Black test points	Keystone	5001
R5, R7, R8, R12	Resistors, 0 Ω , 1/10 W, 0603, do not install (DNI)	Panasonic	ERJ-3GEY0R00V

NOTES

**ESD Caution**

ESD (electrostatic discharge) sensitive device. Charged devices and circuit boards can discharge without detection. Although this product features patented or proprietary protection circuitry, damage may occur on devices subjected to high energy ESD. Therefore, proper ESD precautions should be taken to avoid performance degradation or loss of functionality.

Legal Terms and Conditions

By using the evaluation board discussed herein (together with any tools, components documentation or support materials, the "Evaluation Board"), you are agreeing to be bound by the terms and conditions set forth below ("Agreement") unless you have purchased the Evaluation Board, in which case the Analog Devices Standard Terms and Conditions of Sale shall govern. Do not use the Evaluation Board until you have read and agreed to the Agreement. Your use of the Evaluation Board shall signify your acceptance of the Agreement. This Agreement is made by and between you ("Customer") and Analog Devices, Inc. ("ADI"), with its principal place of business at One Technology Way, Norwood, MA 02062, USA. Subject to the terms and conditions of the Agreement, ADI hereby grants to Customer a free, limited, personal, temporary, non-exclusive, non-sublicensable, non-transferable license to use the Evaluation Board FOR EVALUATION PURPOSES ONLY. Customer understands and agrees that the Evaluation Board is provided for the sole and exclusive purpose referenced above, and agrees not to use the Evaluation Board for any other purpose. Furthermore, the license granted is expressly made subject to the following additional limitations: Customer shall not (i) rent, lease, display, sell, transfer, assign, sublicense, or distribute the Evaluation Board; and (ii) permit any Third Party to access the Evaluation Board. As used herein, the term "Third Party" includes any entity other than ADI, Customer, their employees, affiliates and in-house consultants. The Evaluation Board is NOT sold to Customer; all rights not expressly granted herein, including ownership of the Evaluation Board, are reserved by ADI. CONFIDENTIALITY. This Agreement and the Evaluation Board shall all be considered the confidential and proprietary information of ADI. Customer may not disclose or transfer any portion of the Evaluation Board to any other party for any reason. Upon discontinuation of use of the Evaluation Board or termination of this Agreement, Customer agrees to promptly return the Evaluation Board to ADI. ADDITIONAL RESTRICTIONS. Customer may not disassemble, decompile or reverse engineer chips on the Evaluation Board. Customer shall inform ADI of any occurred damages or any modifications or alterations it makes to the Evaluation Board, including but not limited to soldering or any other activity that affects the material content of the Evaluation Board. Modifications to the Evaluation Board must comply with applicable law, including but not limited to the RoHS Directive. TERMINATION. ADI may terminate this Agreement at any time upon giving written notice to Customer. Customer agrees to return to ADI the Evaluation Board at that time. LIMITATION OF LIABILITY. THE EVALUATION BOARD PROVIDED HEREUNDER IS PROVIDED "AS IS" AND ADI MAKES NO WARRANTIES OR REPRESENTATIONS OF ANY KIND WITH RESPECT TO IT. ADI SPECIFICALLY DISCLAIMS ANY REPRESENTATIONS, ENDORSEMENTS, GUARANTEES, OR WARRANTIES, EXPRESS OR IMPLIED, RELATED TO THE EVALUATION BOARD INCLUDING, BUT NOT LIMITED TO, THE IMPLIED WARRANTY OF MERCHANTABILITY, TITLE, FITNESS FOR A PARTICULAR PURPOSE OR NON-INFRINGEMENT OF INTELLECTUAL PROPERTY RIGHTS. IN NO EVENT WILL ADI AND ITS LICENSORS BE LIABLE FOR ANY INCIDENTAL, SPECIAL, INDIRECT, OR CONSEQUENTIAL DAMAGES RESULTING FROM CUSTOMER'S POSSESSION OR USE OF THE EVALUATION BOARD, INCLUDING BUT NOT LIMITED TO LOST PROFITS, DELAY COSTS, LABOR COSTS OR LOSS OF GOODWILL. ADI'S TOTAL LIABILITY FROM ANY AND ALL CAUSES SHALL BE LIMITED TO THE AMOUNT OF ONE HUNDRED US DOLLARS (\$100.00). EXPORT. Customer agrees that it will not directly or indirectly export the Evaluation Board to another country, and that it will comply with all applicable United States federal laws and regulations relating to exports. GOVERNING LAW. This Agreement shall be governed by and construed in accordance with the substantive laws of the Commonwealth of Massachusetts (excluding conflict of law rules). Any legal action regarding this Agreement will be heard in the state or federal courts having jurisdiction in Suffolk County, Massachusetts, and Customer hereby submits to the personal jurisdiction and venue of such courts. The United Nations Convention on Contracts for the International Sale of Goods shall not apply to this Agreement and is expressly disclaimed.