



SFS01 EvaKit

Thermal mass flow sensor

Optimal for demonstration and evaluation of the SFS01 (Silicon Flow Sensor)

Benefits & Characteristics

Characteristics

- Measurement from 0 to 200 sccm
- Detection of flow direction
- Analog and digital (I²C) connection
- Pneumatic connections for gas

Applications

- Automation technology
- Process and regulation technology
- Medicinal and biological technology
- Air conditioning
- Battery-operated applications in portable devices

Illustration

Illustration and dimensions (in mm) of the SFS chip

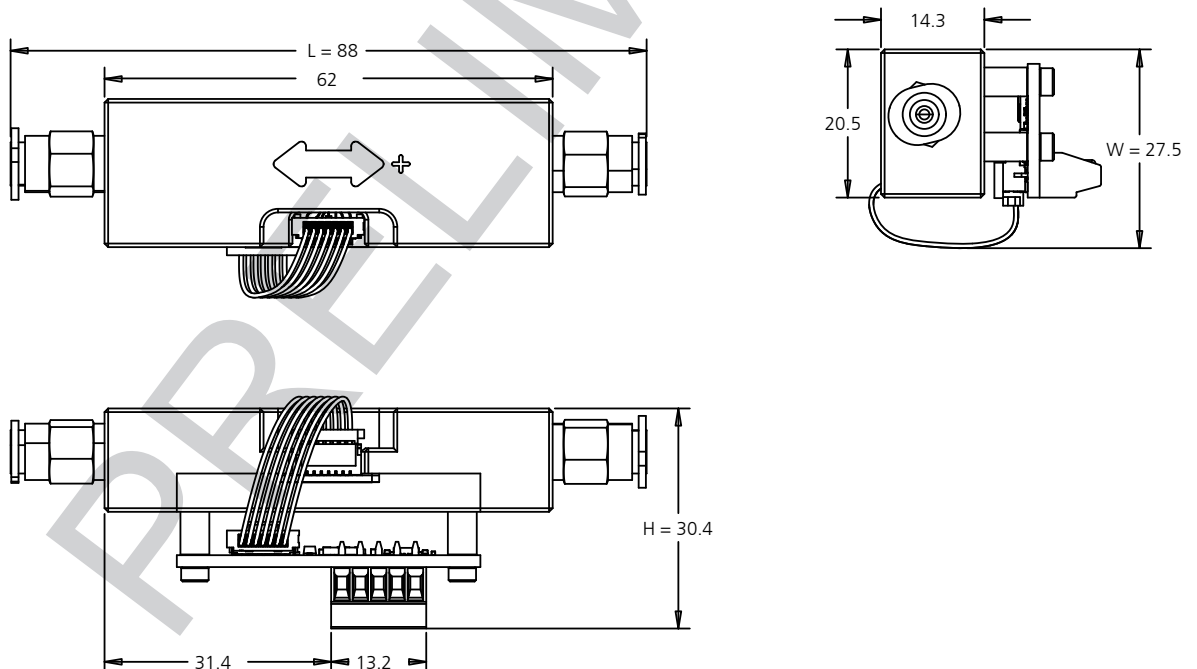

1) For exact size see measurements



Technical Data

Integrated sensor:	SFS01
Dimensions (L x W x H):	88.0 (±0.5) x 27.5 (±1.0) x 30.4 (±0.5)
Channel dimensions (L x W x H):	35.0 (±0.15) x 1.0 (±0.05) x 1.0 (±0.05)
Pneumatic connections:	QSM M5-4
Temperature range:	0 °C to +80 °C
Storage temperature:	-20 °C to +80 °C
Pressure load:	Up to 1 bar (one-sided on membrane over 10 years)

Product Photo

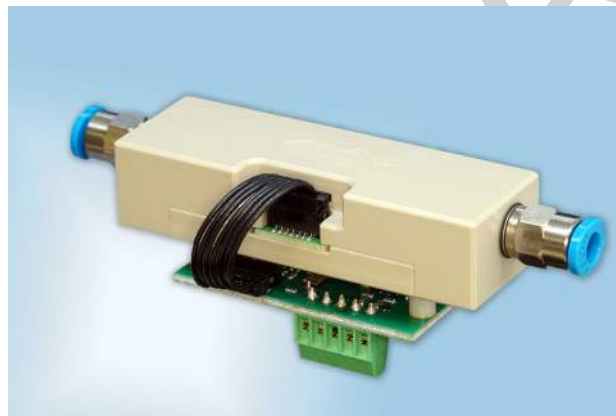

Electrical Data

Supply voltage:	5 ± 5% V
Power:	Typ 30 mW
Output voltage:	0 to 5 V, ca. 2.5 ±0.2 V at 0 sccm
Digital connection:	3.3 V I ² C (pull up resistors on board)
Digital signal:	Calibrated signal (up to ±200 sccm) Raw signal (digits)
Analog output load:	< 1 mA

Flow Performance

The following values are viewed as typical and achieved in laboratory conditions. The gas used was nitrogen.

Medium:	non-aggressive gases (5-95 % rel. humidity, non-condensing)
Measurement range:	0 to ±200 sccm
Sensitivity:	0.1 sccm
Response time t_{63} :	10 ms
Accuracy:	3.0 % F.S.
Temperature sensitivity:	< 0.25 %/K F.S.



Pin Assignment

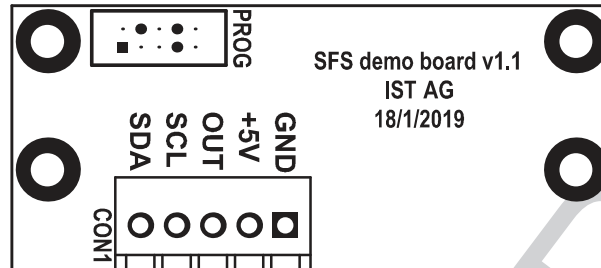

1	2	3	4	5
SDA Serial Data	SCL Serial Clock	OUT Output	+5V Supply voltage	GND Ground

I²C Protocol

I²C Protocol Description

For integration with a micro-controller, the SFS Demo Board has an I²C-compatible interface which supports both 100 kHz and 400 kHz bit rates. The default I²C slave address is programmed on 0x28 and can be adjusted in the entire 7-bit address range (0x00 to 0x7F).

Parameter	min	max	unit
f_{SCL} SCL clock frequency	100	400	kHz
$t_{HD,STA}$ Hold time (repeated) START	0.6		μ s
$t_{SU,STA}$ Setup time for a repeated START	0.6		μ s
$t_{HD,DAT}$ Data hold time	0		μ s
$t_{SU,DAT}$ Data setup time	250		μ s
$t_{SU,STO}$ Setup time for STOP	0.6		μ s
t_{SP} Pulse duration of spikes suppressed by input filter	50	600	ns

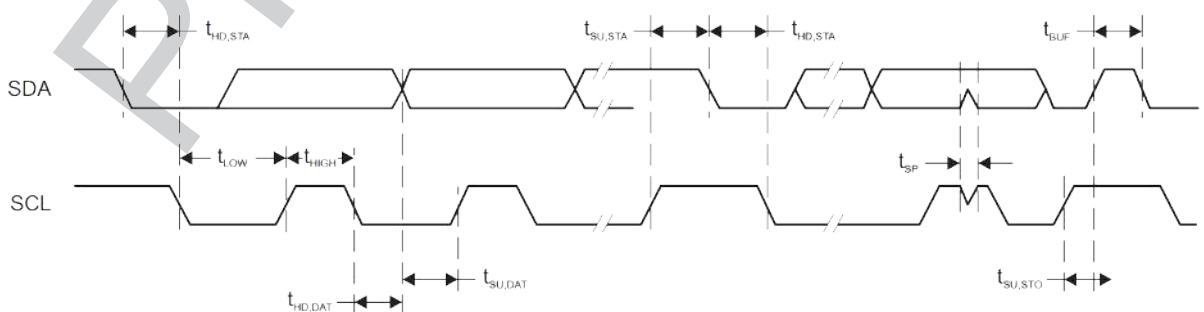



Reading parameters from the module

After successful read instruction the module fills the I²C buffer with the selected parameter. All parameters read from the module, except I²C_address, Serial Number and Firmware Revision, are in signed fixed-point long IQ22 format (4 bytes). To convert them to decimal format the read value has to be divided by $2^{22} = 4\,194\,304$. The minimum value is -512, the maximum value is 511.999 999 762. The resolution of each parameter is $1/2^{22} = 0.000\,000\,238$. I²C_address, Serial Number and Firmware Revision parameters are read in unsigned long format. Additionally, I²C_address is internally masked with 0x3ff.

Start	Address	R	ACK	Data[3]	ACK	Data[2]	ACK	...	Data[0]	ACK	Stop
-------	---------	---	-----	---------	-----	---------	-----	-----	---------	-----	------

Data		Parameter
Data [3]	1 st byte (highest)	Parameter
Data [2]	2 nd byte	
Data [1]	3 rd byte	
Data [0]	4 th byte (lowest)	

After transmitting 4 bytes, the module resets the internal timer and waits in command mode for the next command. The module will reboot automatically after 0.5 second of idle or unsuccessful transmission.

Writing parameters to the module

After successful write instruction the module waits for 4 bytes with the new parameter. All parameters except I²C_address, Serial Number and Firmware Revision written to the module are in signed fixed-point long IQ22 format (4 bytes). In order to convert decimal format to IQ22, the decimal value has to be multiplied by $2^{22} = 4\,194\,304$. To reduce the error, this calculation should be done as double precision floating point number. The minimum value is -512, the maximum value is 511.999 999 762. The resolution of each parameter is $1/2^{22} = 0.000\,000\,238$. I²C_address, Serial Number and Firm-ware Revision parameters are written in unsigned long format. Additionally, I²C_address is internally masked with 0x3ff. Please mind that the new I²C address applies after reboot. The module requires up to 1 ms after stop bit to flash the internal memory with the new parameter.

Start	Address	W	ACK	Data[3]	ACK	Data[2]	ACK	...	Data[0]	ACK	Stop
-------	---------	---	-----	---------	-----	---------	-----	-----	---------	-----	------

Data		Parameter
Data [3]	1 st byte (highest)	Parameter
Data [2]	2 nd byte	
Data [1]	3 rd byte	
Data [0]	4 th byte (lowest)	

After receiving 4 bytes, the module resets the internal timer and waits in command mode for the next command. The module will reboot automatically after 0.5 second of idle or unsuccessful transmission.

Exit command code

After receiving this command, the module returns to normal operation, taking the new parameters' values except the I²C address.

Start	Address	W	ACK	Data = 0xA1	ACK	STOP
-------	---------	---	-----	-------------	-----	------



Reboot

After receiving this command, the module reboots.

Start	Address	W	ACK	Data = 0xA2	ACK	STOP
-------	---------	---	-----	-------------	-----	------

Typical parameter's read sequence

To read parameter(s) from the flash memory please follow steps:

1. Write 0xA0 to the module – start the command mode
2. Wait 1 ms
3. Write 0x00...0x07 to the module – an address of the parameter
4. Wait 1 ms
5. Read 4 bytes from the module
6. If needed repeat steps 3-5 for another parameter
7. Write 0xA1 to the module – exit command mode

Typical parameter's write sequence

To write parameter(s) to the flash memory please follow steps:

1. Write 0xA0 to the module – start the command mode
2. Wait 1 ms
3. Write 0x20...0x25 to the module – an address of the parameter
4. Wait 1 ms
5. Write 4 bytes to the module
6. Wait 1 ms
7. If needed repeat steps 3-6 for another parameter
8. Write 0xA1 to the module – exit command mode or 0xA2 – reboot the module

Parameter's description

Parameters: Flow A, Flow B, Flow C, Flow D are used to calculate flow from heater's power, and fluids temperature using equation:

$$flow = A + B \frac{RAW}{2^{10}} + C \left(\frac{RAW}{2^{10}} \right)^2 + D \left(\frac{RAW}{2^{10}} \right)^3$$

Where:

A: flow A, B: flow B, C: flow C, D: flow D

RAW: Raw flow value

Parameter Flow's Range limits the maximum and minimum calibrated flow's readout from the module. It should be written as the last calibration point (or slightly higher). It prohibits the user to measure the flow outside the calibration's range.



Order Information

Description:	Item number:	Former main reference:
SFS01 EvaKit	105059	350.0033

Additional Products

Description:	Item number:	Former main reference:
SFS01	105050	350.00312

Order Information

Application Note:	Document name:
	AFSFS01_E

PRELIMINARY

