

REVISIONS					
P	LTR	DESCRIPTION	DATE	DWN	APVD
E1		REVISED PER ECR-22-125659	25MAR2022	RR	SZ

NOTES:

- MATERIAL:
 - HOUSING: THERMOPLASTIC(NYLON 6T), UL94V-0
D-SUB 9M COLOR: TURQUOISE (322C)
D-SUB 15F COLOR: BLUE (661C)
 - CONTACTS: BRASS
 - SHELL: STEEL
 - BOARDLOCK: BRASS
 - FINISH:
 - CONTACTS: GOLD PLATED(SEE TABLE) ON CONTACT AREA 100u" MIN. BRIGHT TIN PLATED ON SOLDER TAILS 50u" MIN. NICKEL UNDERPLATED ALL OVER (FOR PN 2-1775210-1 & 2-1775210-2)
GOLD PLATED(SEE TABLE) ON CONTACT AREA 100u" MIN. MATTE TIN PLATED ON SOLDER TAILS 50u" MIN. NICKEL UNDERPLATED ALL OVER
 - SHELL: 50u" MIN NICKEL PLATED
 - BOARDLOCK: 100u" MIN BRIGHT TIN PLATED
50u" MIN. NICKEL UNDERPLATED ALL OVER (FOR PN 2-1775210-1 & 2-1775210-2)
100u" MIN MATTE TIN PLATED
50u" MIN. NICKEL UNDERPLATED ALL OVER
 - RECOMMENDED PCB THICKNESS 1.6mm
 - WAVE SOLDER CAPABLE TO 265°C PER TE SPEC. 109-202, CONDITION B
- ⚠ DIM A IS SCREW HEAD LENGTH

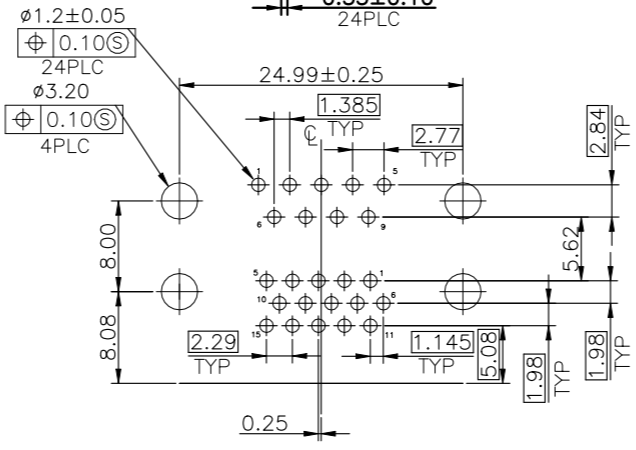
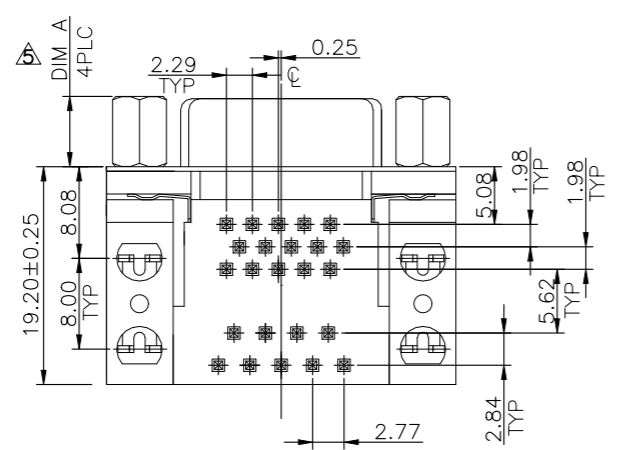
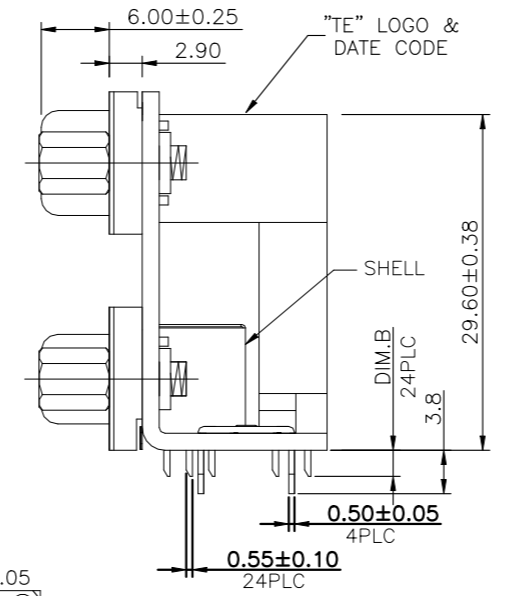
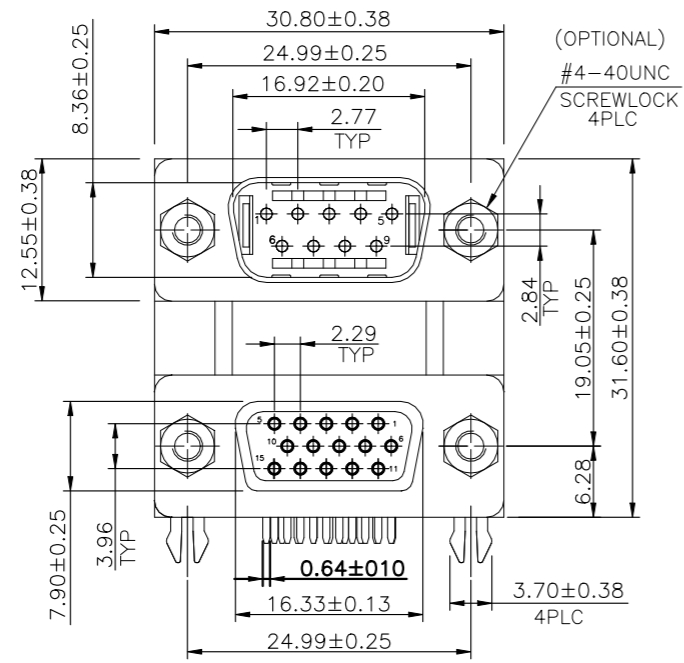

RECOMMENDED P.C.B. LAYOUT TOLERANCE: ±0.05

OBSELETE

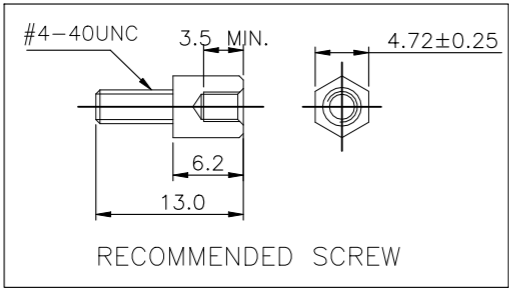

EOL	W/O	W/O	G/F	3.18±0.38	6.2	1-1775210-4
EOL	W/O	W/	G/F	3.18±0.38	6.2	1-1775210-3
EOL	W/	W/O	G/F	3.18±0.38	6.2	1-1775210-2
EOL	W/	W/	G/F	3.18±0.38	6.2	1-1775210-1
EOL	W/O	W/O	G/F	3.18±0.38	4.8	1775210-4
EOL	W/O	W/	G/F	3.18±0.38	4.8	1775210-3
EOL	W/	W/O	G/F	3.18±0.38	4.8	1775210-2
EOL	W/	W/	G/F	3.18±0.38	4.8	1775210-1
SCREWLOCK	SHELL	GOLD THK.	DIM B	⚠ DIM A	PART NUMBER	

THIS DRAWING IS A CONTROLLED DOCUMENT.

DIMENSIONS:	TOLERANCES UNLESS OTHERWISE SPECIFIED:
mm	
	0 PLC ± -
	1 PLC ± 0.3
	2 PLC ± 0.2
	3 PLC ± -
	4 PLC ± -
ANGLES	± 3°
MATERIAL	FINISH
-	-

DWN	S. CHIEN	20MAR2015
CHK	S. CHIEN	20MAR2015
APVD	W. KODAMA	20MAR2015
PRODUCT SPEC	108-57203	
APPLICATION SPEC	501-57200	
WEIGHT	26.0 GRAMS	

STE TE Connectivity Ltd.

NAME: D-SUB 5.08mm, 9 POS PLUG OVER 15 POS RCPT

SIZE	CAGE CODE	DRAWING NO	RESTRICTED TO
A3	00779	C-1775210	-

CUSTOMER DRAWING SCALE 1:1 SHEET 1 OF 3 REV E1

REVISIONS

P	LTR	DESCRIPTION	DATE	DWN	APVD
-	-	SEE SHEET 1	-	-	-

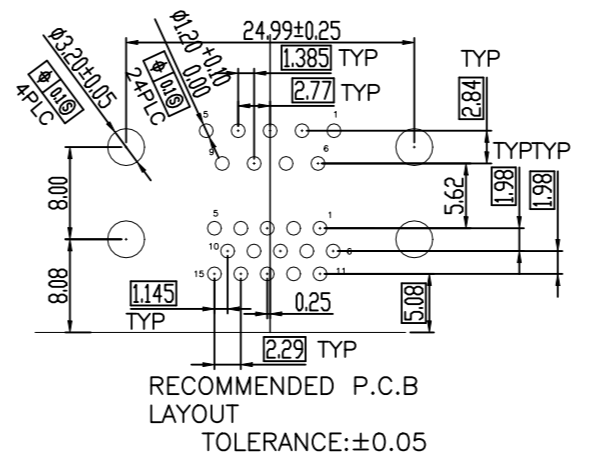
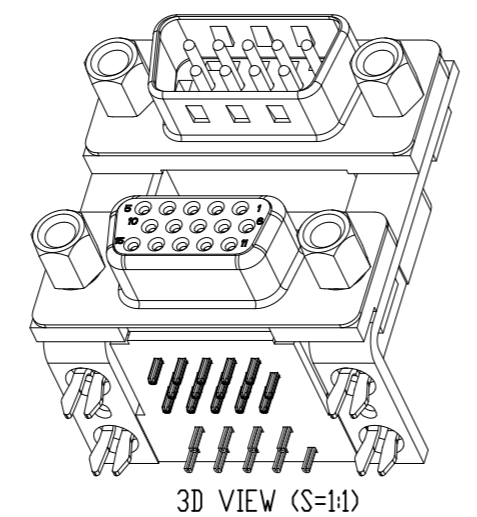
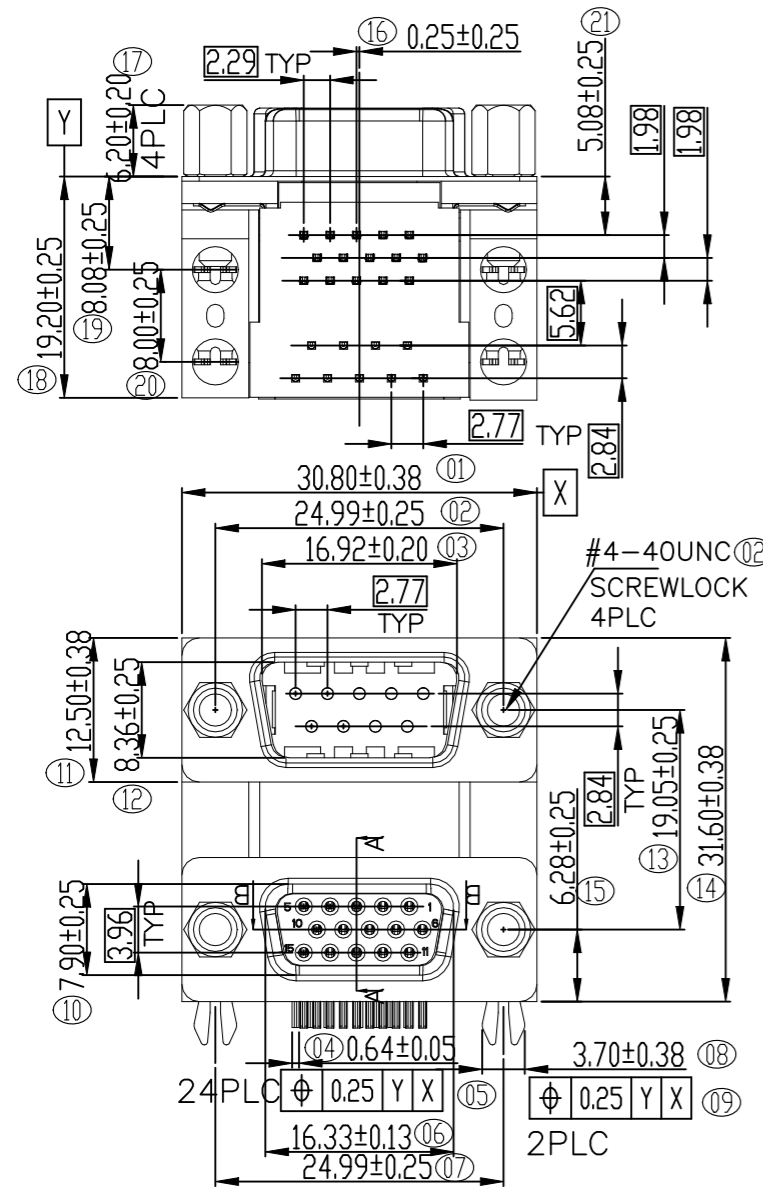

NOTES:

- MATERIAL:
 - HOUSING: THERMOPLASTIC(NYLON 10T), UL94V-0
D-SUB 9M COLOR: TURQUOISE (322C)
D-SUB 15F COLOR: BLUE (661C)
 - CONTACTS: BRASS
 - SHELL: SPCC
 - BOARDLOCK: BRASS
- FINISH:
 - CONTACTS: GOLD PLATED(SEE TABLE) ON CONTACT AREA
(FOR PN 2-1775210-1 & 2-1775210-2)
GOLD PLATED(SEE TABLE) ON CONTACT AREA
100u" MIN. MATTE TIN PLATED ON SOLDER TAILS
50u" MIN. NICKEL UNDERPLATED ALL OVER
 - SHELL: 50u" MIN NICKEL PLATED
 - BOARDLOCK:(FOR PN 2-1775210-1 & 2-1775210-2)
100u" MIN MATTE TIN PLATED
50u" MIN. NICKEL UNDERPLATED ALL OVER
- RECOMMENDED PCB THICKNESS 1.6mm
- WAVE SOLDER CAPABLE TO 265°C PER TE SPEC. 109-202, CONDITION B
- DIM A IS SCREW HEAD LENGTH

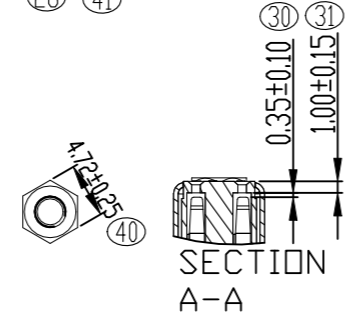
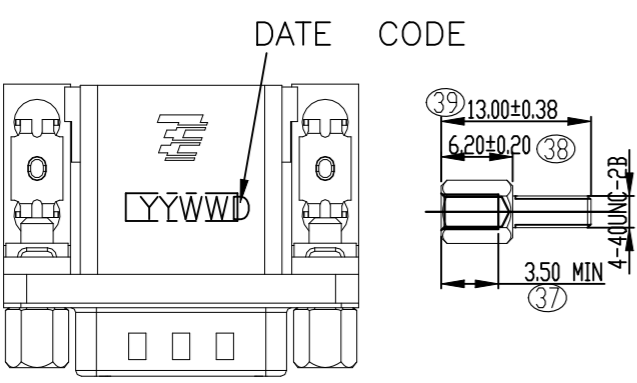
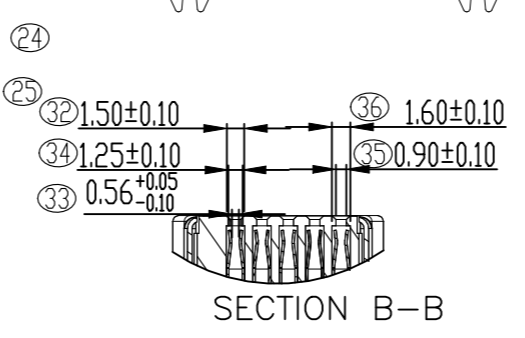
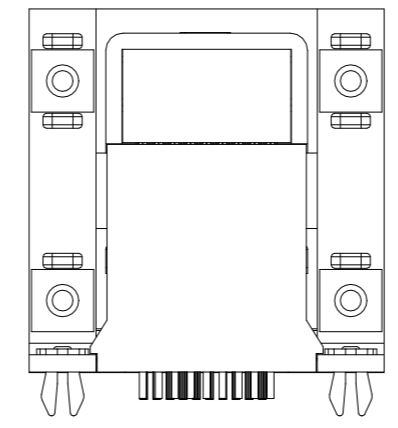
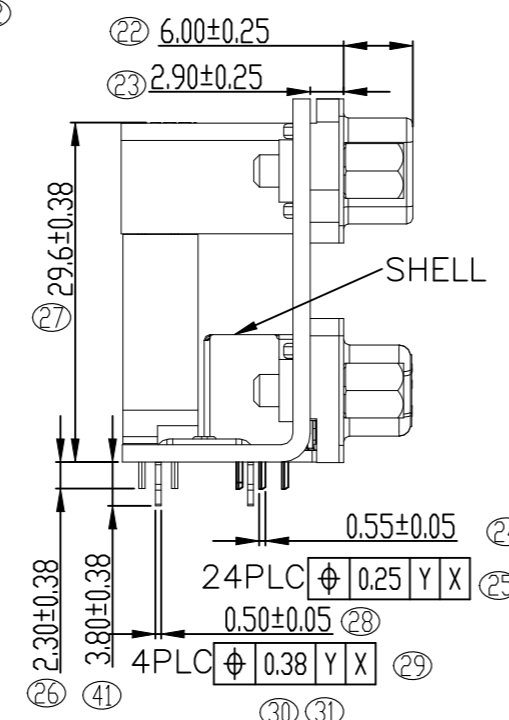

W/	W/O	30u" MIN	2-1775210-2
W/	W/	30u" MIN	2-1775210-1
SCREWLOCK	SHELL	GOLD THK.	PART NUMBER

THIS DRAWING IS A CONTROLLED DOCUMENT.		DWN S. CHIEN 20MAR2015	TE Connectivity Ltd.	
DIMENSIONS: mm		CHK S. CHIEN 20MAR2015		
TOLERANCES UNLESS OTHERWISE SPECIFIED:		APVD W. KODAMA 20MAR2015	NAME	
0 PLC ± 0.5		PRODUCT SPEC 108-57203		
1 PLC ± 0.38		APPLICATION SPEC 501-57200		
2 PLC ± 0.25		WEIGHT 26.0 GRAMS		RESTRICTED TO
3 PLC ± -		CUSTOMER DRAWING		SCALE 1:1
4 PLC ± -		SIZE 501-57200		SHEET 2 OF 3
ANGLES ± 3°		CAGE CODE A300779		REV E1
FINISH -		DRAWING NO C-1775210		

REVISIONS

P	LTR	DESCRIPTION	DATE	DWN	APVD
-	-	SEE SHEET 1	-	-	-

NOTES:

- 1. MATERIAL:
 - 1.1 TRAY: PVC
 - 1.2 SHIPPING CARTON: CORRUGATED FIBERBOARD
- 2. DIMENSION:
 - 2.1 TRAY: L=285, W=270, H=30
 - 2.2 CARTON: L=298, W=283, H=170
- 3. QUANTITY:
 - 3.1 40 PCS/TRAY
 - 3.2 5 TRAYS/CARTON (200 PCS)
- 4. WEIGHT:
 - 4.1 NET WEIGHT: 5KG/CARTON
 - 4.2 GROSS WEIGHT: 6KG/CARTON

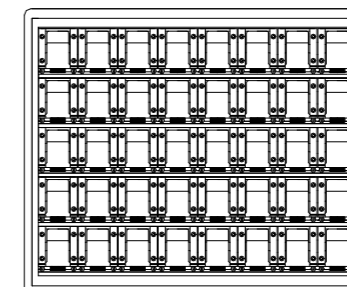
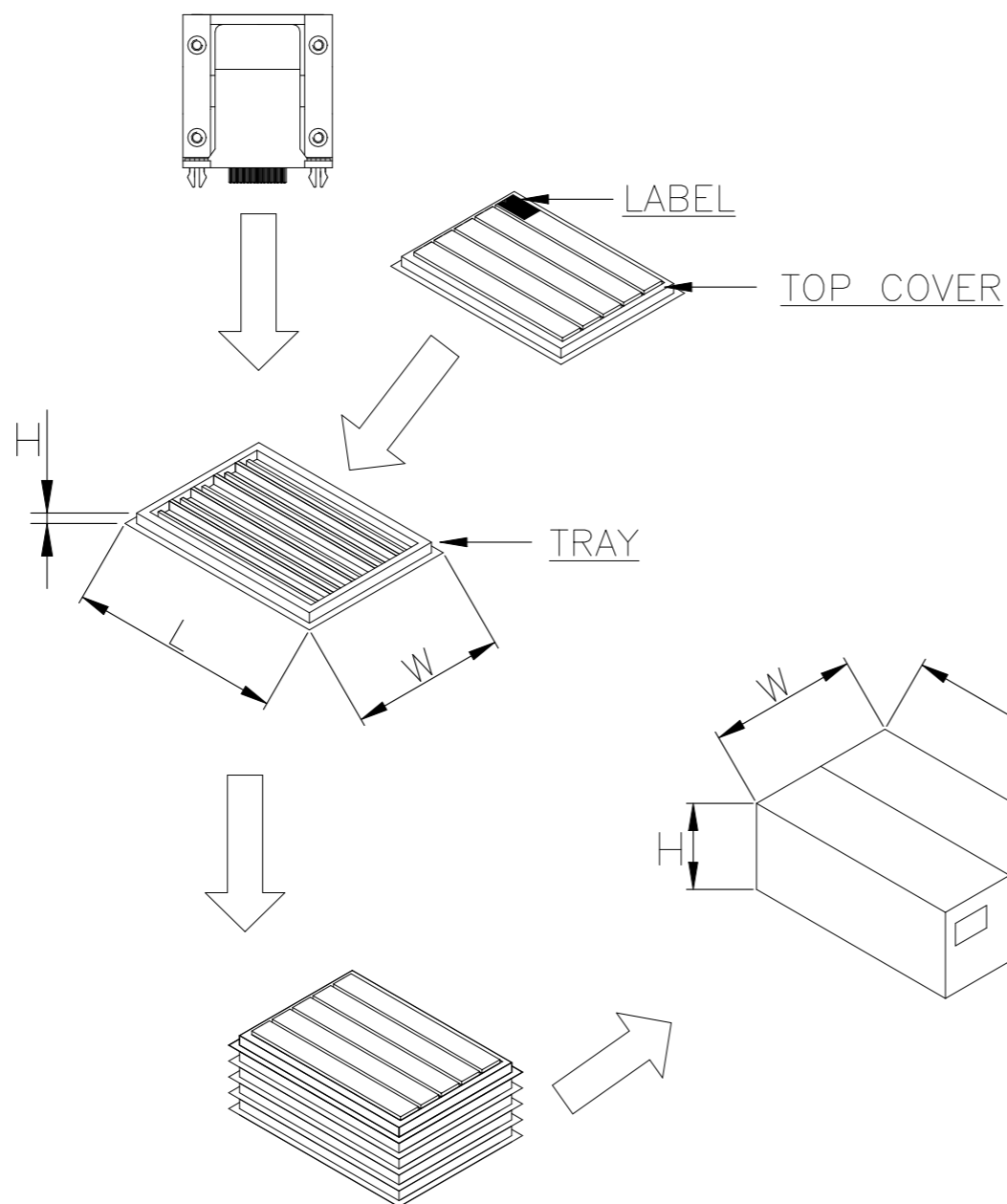

TRAY LAYOUT

THIS DRAWING IS A CONTROLLED DOCUMENT.		DWN S. CHIEN 20MAR2015	 TE Connectivity Ltd.														
DIMENSIONS: mm		CHK S. CHIEN 20MAR2015															
TOLERANCES UNLESS OTHERWISE SPECIFIED:		APVD W. KODAMA 20MAR2015	NAME D-SUB 5.08mm, 9 POS PLUG OVER 15 POS RCPT														
<table border="1"> <tr> <td>0 PLC</td> <td>± -</td> </tr> <tr> <td>1 PLC</td> <td>± 0.3</td> </tr> <tr> <td>2 PLC</td> <td>± 0.2</td> </tr> <tr> <td>3 PLC</td> <td>± -</td> </tr> <tr> <td>4 PLC</td> <td>± -</td> </tr> <tr> <td>ANGLES</td> <td>± 3°</td> </tr> </table>		0 PLC	± -	1 PLC	± 0.3	2 PLC	± 0.2	3 PLC	± -	4 PLC	± -	ANGLES	± 3°	PRODUCT SPEC 108-57203	RESTRICTED TO		
0 PLC	± -																
1 PLC	± 0.3																
2 PLC	± 0.2																
3 PLC	± -																
4 PLC	± -																
ANGLES	± 3°																
MATERIAL		APPLICATION SPEC 501-57200	SIZE A3	CAGE CODE 00779	DRAWING NO C-1775210												
FINISH		WEIGHT 26.0 GRAMS	SCALE 1:1														
		CUSTOMER DRAWING		SHEET 3 OF 3	REV E1												