

		
Modular Crimp Head Order No. 63819-8370	Application Tooling Specification Sheet	TYPE 4A Hand Crimp Tool Order No. 63819-8300

FEATURES

- % A full cycle ratcheting hand tool ensures complete crimps
- % Ergonomically designed soft handles
- % Precisely designed crimping profiles with simple contact positioning
- % Easy handling due to outstanding force ratio
- % Modular Crimp Head is removable and can be use in the Air Powered Tool Order No.63816-0100, accompanied by Air Powered Crimp Adapter (Order No. 63816-0700).
- % Can also be used in the Battery Powered Tool Order No.63816-0200 (110 V) or 63816-0250 (220 V), accompanied by Battery Powered Crimp Adapter (Order No. 63816-0600).

SCOPE

Products: CTX280 Receptacle Terminals: 0.50-1.00mm² metric, type ISO wire.

Terminal Series No.	Terminal Order No.	Wire Size and Type		** Insulation Diameter		Strip Length	
	*Reel Form Only	Mm2	Type	mm	In.	mm	In.
98675	98675-0001, 98675-0011 98675-0021, 98675-0031	0.50	ISO	1.40-1.60	.055-.063	4.30-4.80	.169-.189
		0.75	ISO	1.60-1.90	.063-.075		
		1.00	ISO	1.75-2.10	.069-.083		

*Customer to cut off terminal from reel: 0.30mm (.012") maximum Cut-off Tab.
 ** See crimp specification for the individual Insulation Diameter.

DEFINITION OF TERMS

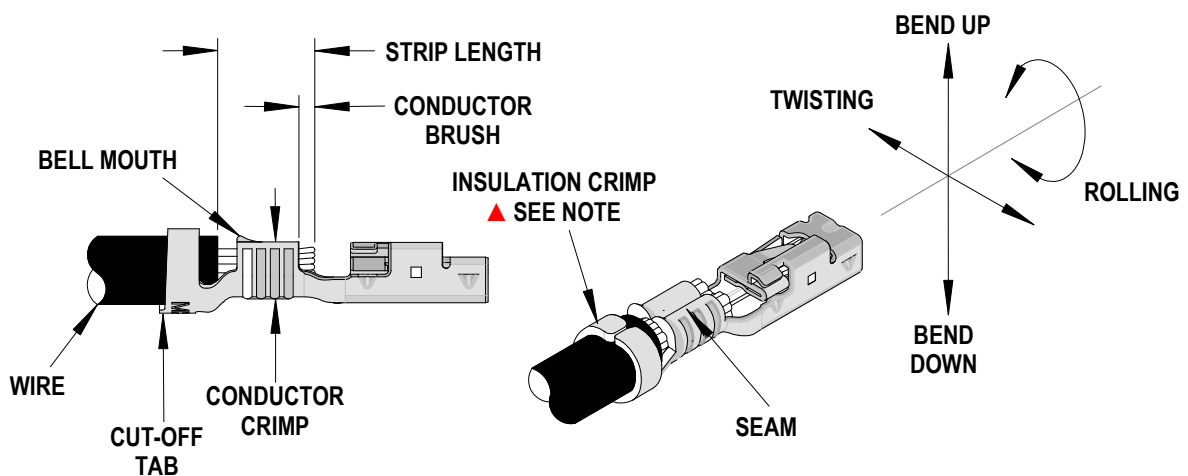

▲ Insulation Crimp Note:

Due to the terminal's insulation grip design and/or insulation diameter range, this tool uses "overlap" form geometry in the insulation punch. This produces an overlap insulation crimp (A620 – compliant). While the insulation punch profile may appear "lopsided", this is a normal condition for this tool. See figure to the right. (Some tools with multiple crimp pockets may not have the "overlap" profile on all pockets).

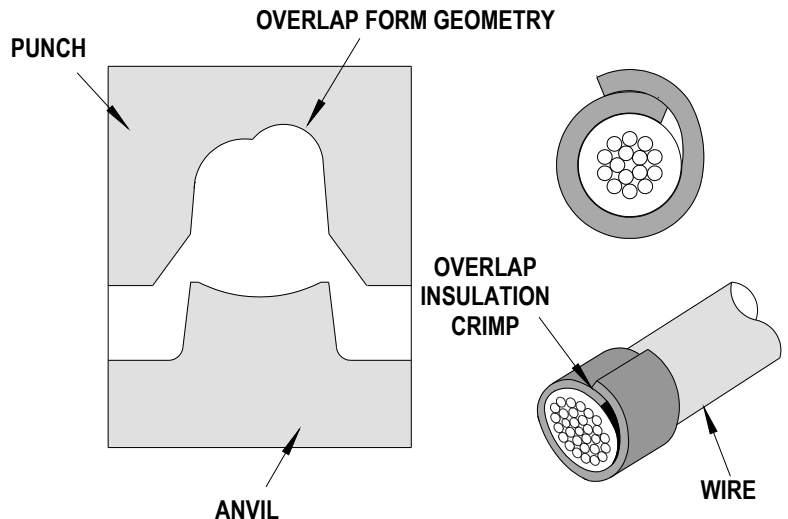

CRIMP SPECIFICATIONS:

Terminal Series No.	Bell mouth		* Conductor Brush		Bend up	Bend Down	Twist Roll	
	mm	In.	mm	In.	Degree		Degree	
98675	0.40-0.60	.016-.024	0.20-0.60	.008-.024	1	1	2	3

* Not to exceed above the conductor crimp height.

After crimping, the conductor profile should measure the following.

Terminal Series No.	Wire Size	Conductor				Profile		
		Crimp Height		Crimp Width		0.50mm ²	1.00mm ²	0.75mm ²
		mm	In.	mm	In.			
98675	0.50	1.08-1.18	.043-.047	2.02-2.12	.079-.083	X		
	0.75	1.13-1.23	.044-.048	2.02-2.12	.079-.083			X
	1.00	1.20-1.30	.047-.051	2.02-2.12	.079-.083		X	

Terminal Series No.	Wire Size	** Insulation Diameter		Insulation				Pull Force Minimum	
		mm	In.	Crimp Height		Crimp Width		N	Lb.
				mm	In.	mm	In.		
98675	0.50	1.40-1.60	.055-.063	2.20-2.40	.087-.095	2.25-2.35	.089-.093	70.0	15.7
	0.75	1.60-1.90	.063-.075	2.40-2.60	.094-.102	2.25-2.35	.089-.093	90.0	20.2
	1.00	1.75-2.10	.069-.083	2.60-2.80	.102-.110	2.25-2.35	.089-.093	115.0	25.8

CAUTION: Crimp only the Molex terminals listed in the scope for this tool. Do not crimp hardened objects as damage can occur to the tool frame and/or crimp dies.

*** Tool Qualification Notes:**

1. Pull Force should be measured with no influence from the insulation crimp.
2. The above specifications are guidelines to an optimum crimp.

Note:

A crimp height chart is provided with this manual as Reference Only. Due to the wide range of wires, strands, insulation diameters, and durometer available, actual crimp height measurements may vary slightly. An occasional, destructive, pull force test should be performed to check hand tool crimp. Pull Force value must exceed the minimum pull force specification.

OPERATION

Open the tool by squeezing the handles together, at the end of the closing stroke, the ratchet mechanism will release the handles, and the hand tool will spring open.

Crimping Terminals

1. Lift the wire stop blade up.
2. Insert the terminal fully into the correct profile until the terminal is fully seated and stops.
3. Bring down the wire stop blade.
4. Slide the pre-stripped wire into the wire stop blade. See Figure 1. Be sure to hold the wire in place until the terminal is fully crimped. See Figure 2.
5. Close the tool until the ratchet releases, the tool handles will then spring open.
6. Lift the wire stop blade up if it is still in down position.
7. Carefully remove the crimped terminal.

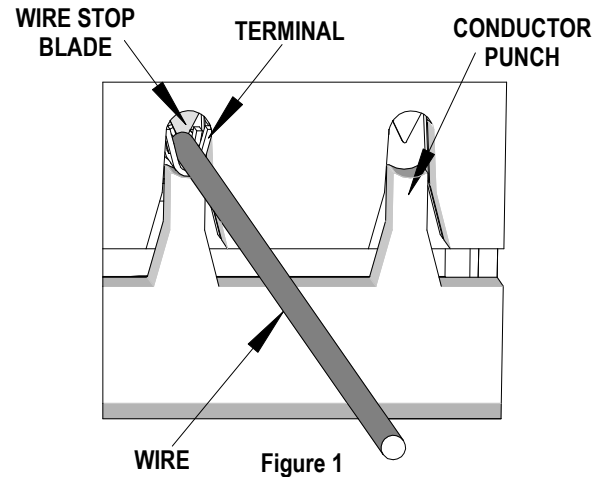

Note: To maintain good brush control and a consistent bell mouth the crimping instructions must be followed.

Note: The tamper proof ratchet action will not release the tool until it has been fully closed.

Maintenance

It is recommended that each operator of the tool be made aware of, and responsible for, the following maintenance steps:

1. Remove dust, moisture, and other contaminants with a clean brush, or soft, lint free cloth.
2. Do not use any abrasive materials that could damage the tool.
3. Make certain all pins; pivot points and bearing surfaces are protected with a thin coat of high quality machine oil. Do not oil excessively. The tool was engineered for durability but like any other equipment it needs cleaning and lubrication for a maximum service life of trouble free crimping. Light oil (such as 30 weight automotive oil) used at the oil points, every 5,000 crimps or 3 months, will significantly enhance the tool life.
4. Wipe excess oil from hand tool, particularly from crimping area. Oil transferred from the crimping area onto certain terminations may affect the electrical characteristics of an application.
5. When tool is not in use, keep the handles closed to prevent objects from becoming lodged in the crimping dies, and store the tool in a clean, dry area.

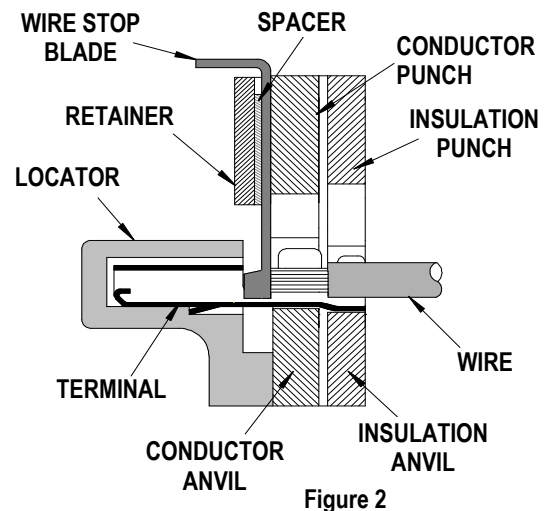

Miscrimps or Jams

Should this tool ever become stuck or jammed in a partially closed position, **Do Not force the handles open or closed**. The tool will open easily by lifting the ratchet release lever. See Figure 6.

Warranty

This tool is for electrical terminal crimping purposes only. This tool is made of the best quality materials. All vital components are long life tested. All tools are warranted to be free of manufacturing defects for a period of 30 days. Should such a defect occur, we will repair or exchange the tool free of charge. This repair or exchange will not be applicable to altered, misused, or damaged tools. This tool is designed for hand use only. Any clamping, fixturing, or use of handle extensions voids this warranty.

CAUTION: Molex crimp specifications are valid only when used with Molex terminals and tooling.

CAUTIONS:

1. Manually powered hand tools are intended for low volume or field repair. This tool is **NOT** intended for production use. Repetitive use of this tool should be avoided.
2. Insulated rubber handles are not protection against electrical shock.
3. Wear eye protection at all times.
4. Use only the Molex terminals specified for crimping with this tool.

Certification

Molex does not certify or re-certify hand tools but rather supplies the following guidelines for customers to re-certify hand tools.

- % This tool is qualified to pull force only. To re-certify, crimp a terminal to a wire, which has been stripped 12.7mm (1/2") long, so there is no crimping of the insulation. Pull the terminal and wire at a rate no faster than 25mm (1.00") per minute. See the Molex web site for the Quality Crimp Handbook for more information on pull testing.
- % If the tool does not meet minimum pull force values, handle preload should be increased and the pull test rerun, (See How to Adjust Preload).
- % When the hand tool is no longer capable of achieving minimum pull force, it should be taken out of service and replaced.

Applications for the Modular Crimp Head

WARNING: NEVER operate, service, install, or adjust this Modular Crimp Head without proper instruction and without first reading and understanding the instructions in the proper Manual or Specification Sheet. See Chart below for the correct Manual or Specification Sheet.

WARNING: NEVER install tooling or service this tool while it is into any power source. Disconnect the power by unplugging or turn off the Actuator from its power source.

CAUTION: Keep fingers away from the crimping area when operating this tool. It may cause severe injury.

CAUTION: Wear safety glasses when operating or serving this tool.

The chart below shows all applications for this Modular Crimp Head.

Modular Crimp Head Order No.	Tool Order no.	Tool Description	Adapter Order No.	Adapter Description	Figure No.
63819-8370	63816-0000	Hand Crimp Frame (Short)	N/A	N/A	3
	63816-0050	Hand Crimp Frame (Long)	N/A	N/A	3
	63816-0200	Battery Power Tool (110 V)	63816-0600	Battery Power Crimp Adapter	4
	63816-0250	Battery Power Tool (220 V)	63816-0600	Battery Power Crimp Adapter	4
	63816-0100	Air Power Tool	63816-0700	Air Power Crimp Adapter	5

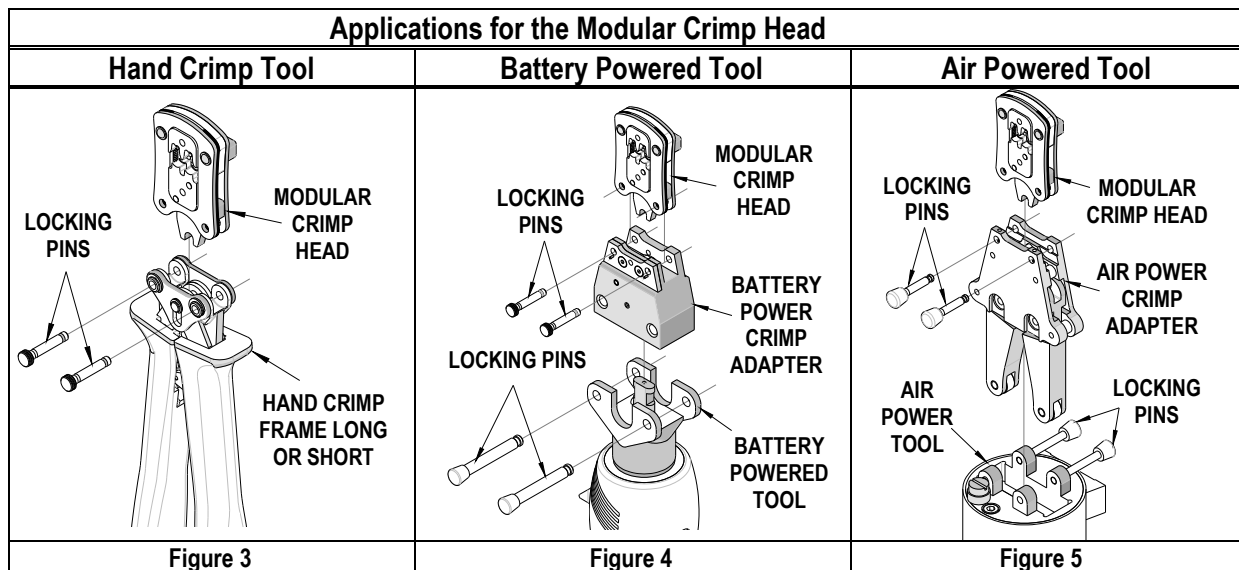

PARTS LIST

Hand Crimp Tool 63819-8300			
Item	Order Number	Description	Quantity
1	63819-8370	Modular Crimp Head	1 (Ref)
2	63816-0050	Hand Crimp Frame (Long)	1 (Ref)
3	63819-8375	Locator	1
4	63816-0001	Locking Pin	2
5	63600-0525	Handle Spring	1
6	63600-0520	Crimping Spring	2

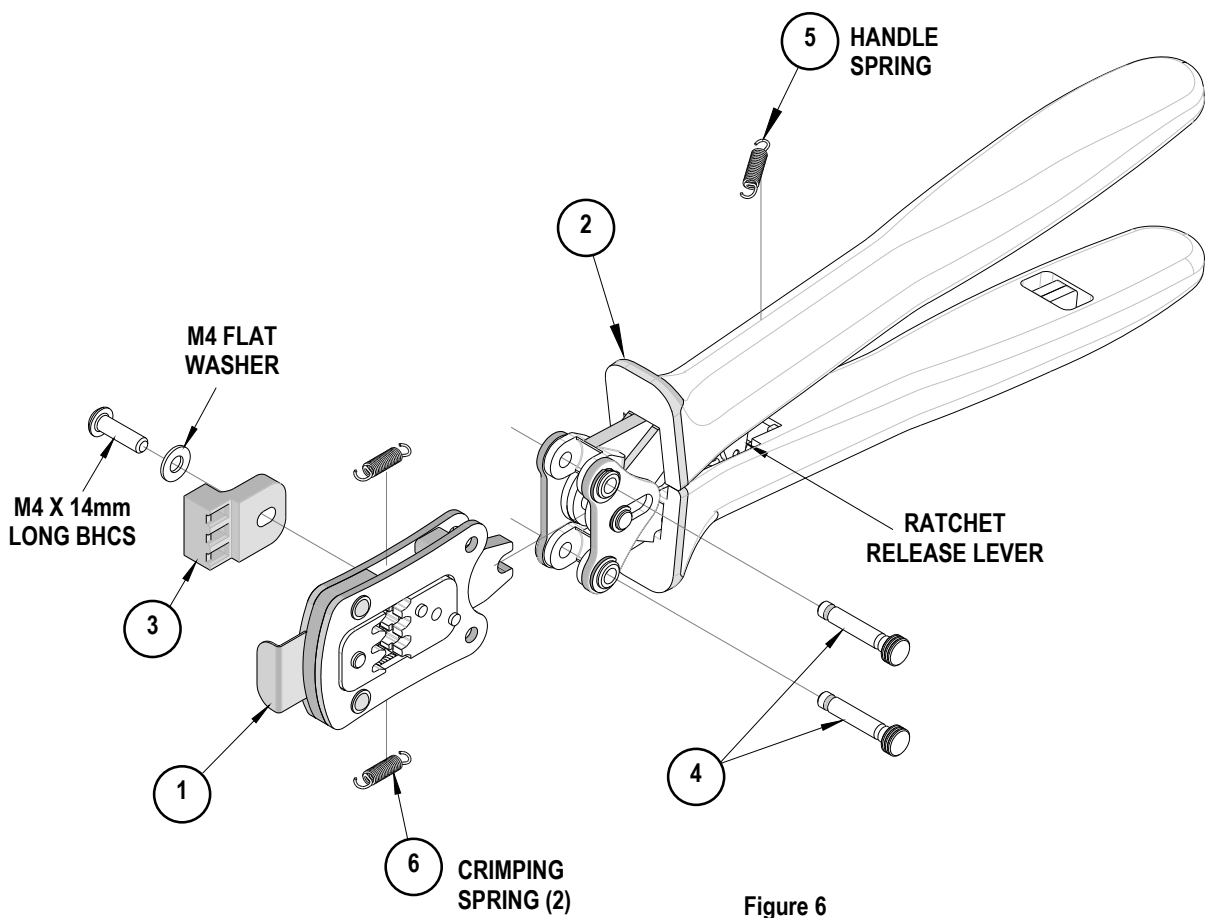

<http://www.molex.com>