

- ① HOUSING: NYLON OR POLYESTER, FLAME RETARDANT 94V-0 RATED, GLASS FILLED, BLACK.  
SHELLS: CARBON STEEL.  
CONTACTS: BRASS.  
BOARDLOCKS: COPPER ALLOY.  
EYELETS: BRASS.
- ② SHELLS: 2.54μm[.000100] MIN TIN OVER 1.27μm[.000050] MIN COPPER.  
EYELETS: 5.08μm[.000200] MIN TIN OVER COPPER FLASH.  
CONTACTS: SEE TABLE.  
BOARDLOCKS: SEE TABLE.  
INSERTS: CLEAR CHROMATE.  
SCREWLOCKS: CLEAR CHROMATE.
- ③ GOLD FLASH ON THE MATING SURFACES, 2.54μm[.000100] MIN TIN OR TIN-LEAD PLATE ON THE SOLDER END, 1.27μm[.000050] MIN NICKEL UNDERPLATE ON THE ENTIRE CONTACT.
- ④ 0.76μm[.000030] MIN GOLD PLATE ON THE MATING SURFACES, 2.54μm[.000100] MIN TIN OR TIN-LEAD PLATE ON THE SOLDER END, 1.27μm[.000050] MIN NICKEL UNDERPLATE ON THE ENTIRE CONTACT  
-OR-  
GOLD FLASH OVER PALLADIUM-NICKEL PLATE, 0.76μm[.000030] MIN TOTAL ON THE MATING SURFACES, 2.54μm[.000100] MIN TIN OR TIN-LEAD PLATE ON THE SOLDER END, 1.27μm[.000050] MIN NICKEL UNDERPLATE ON THE ENTIRE CONTACT.
- ⑤ 5.08μm[.000200] MIN TIN-LEAD OVER 1.27μm [.000050] MIN NICKEL.
- ⑥ 5.08μm[.000200] MIN TIN OVER 1.27μm [.000050] MIN NICKEL.
- ⑦ DIMENSION APPLIES FROM CENTER OF CONTACTS.
- ⑧ SUPERSEDED BY 747842-2.
- ⑨ OBSOLETE PARTS: OBSOLETE CIS STREAMLINING PER D.RENAUD/D.SINISI.

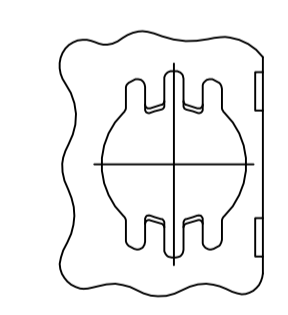

FOR -5 AND -6 ONLY  
DETAIL F  
2 PLC

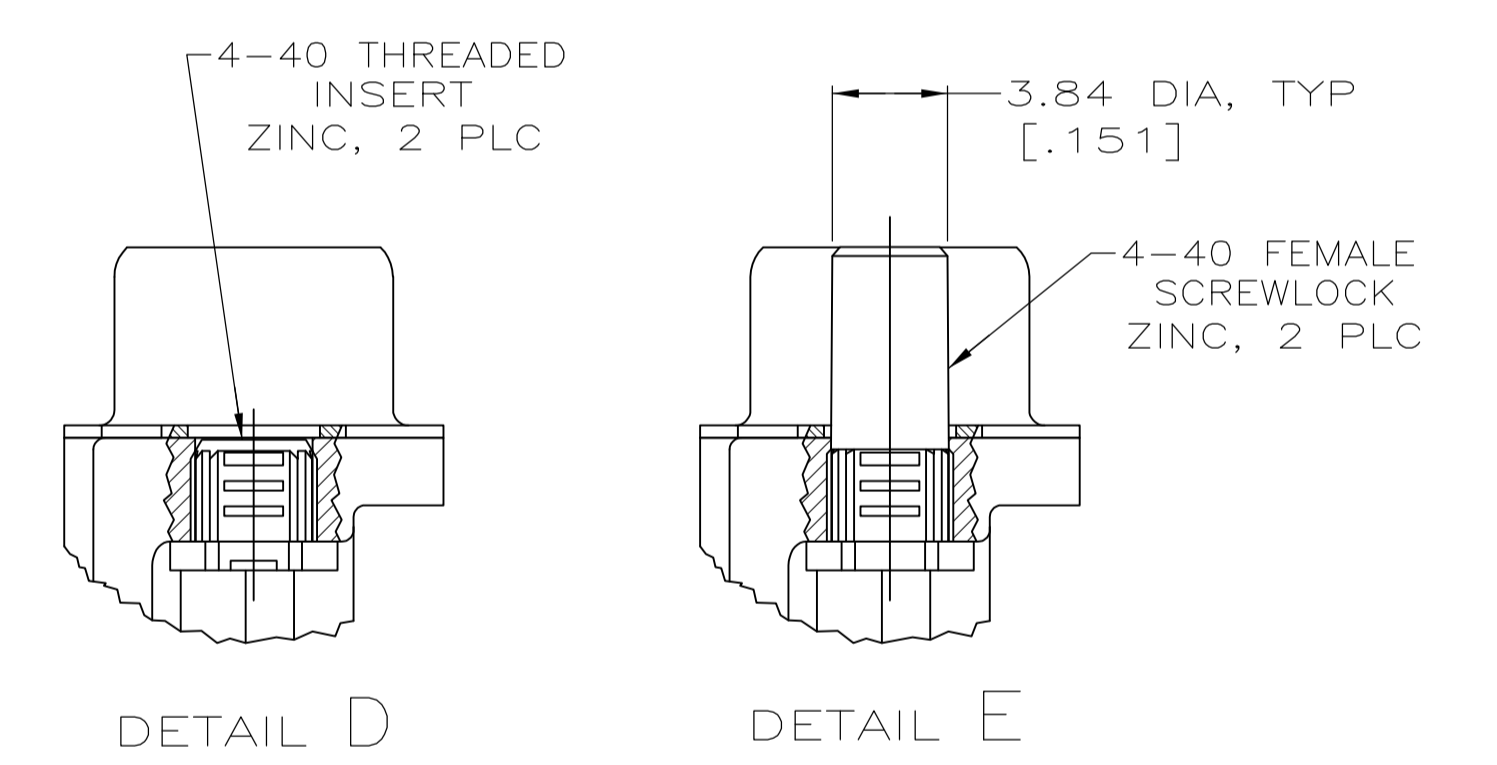
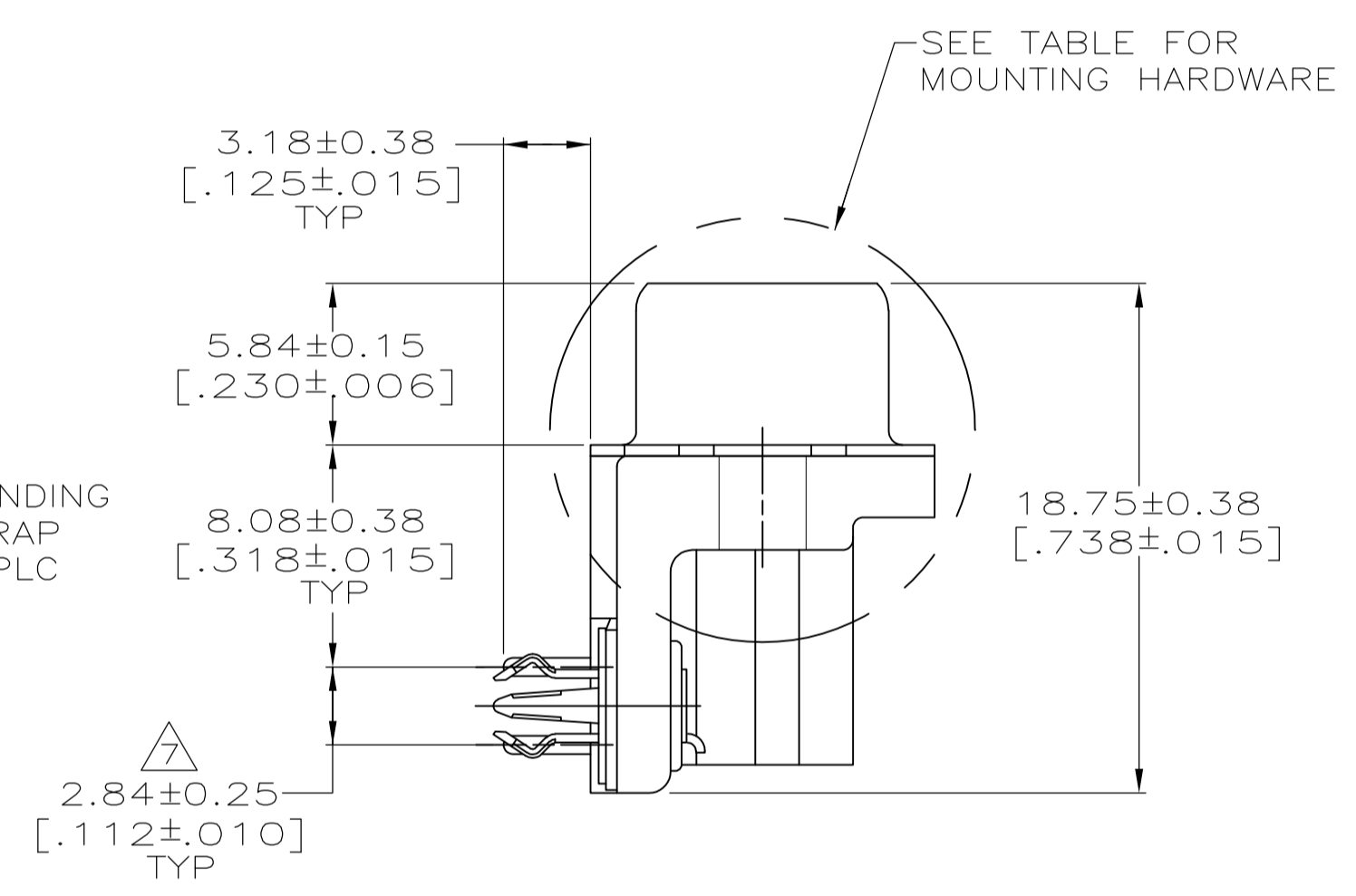
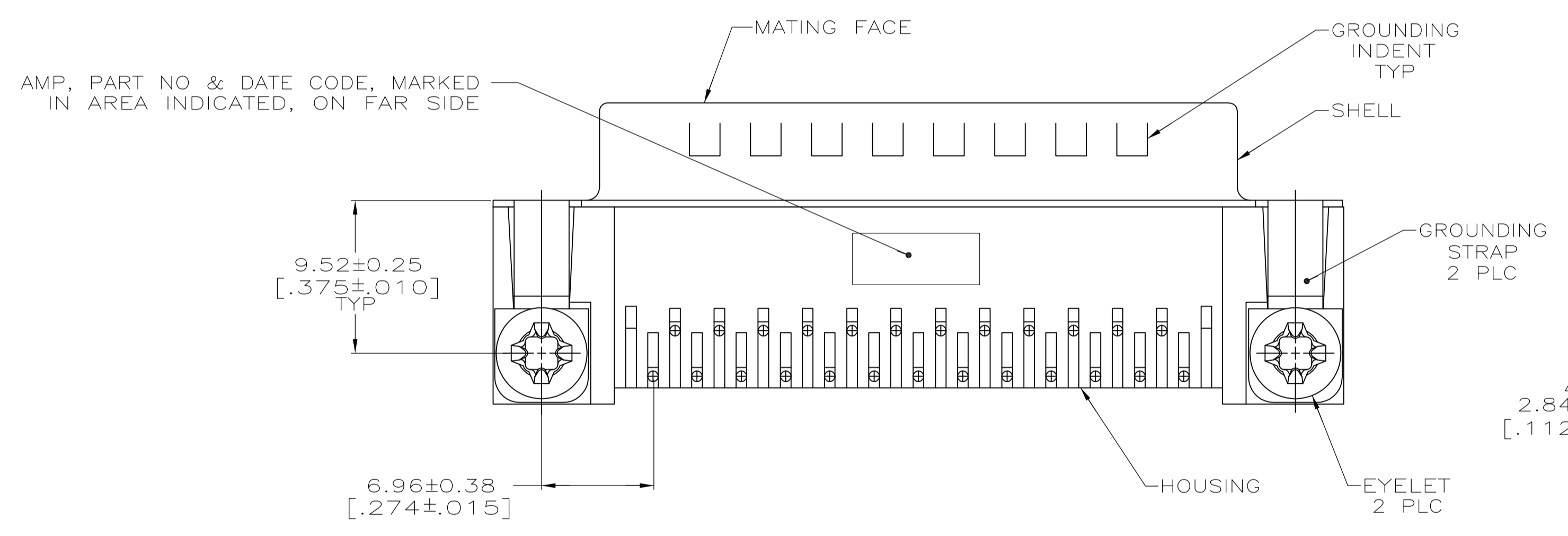
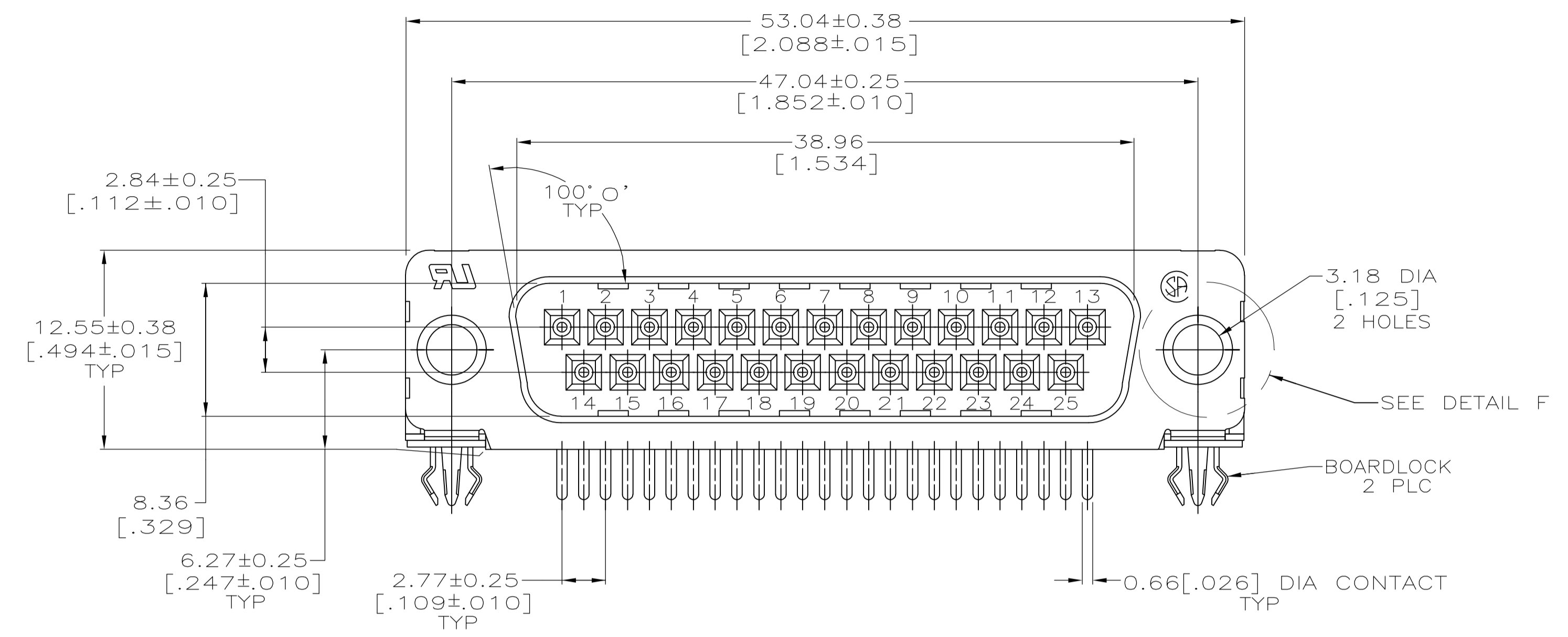
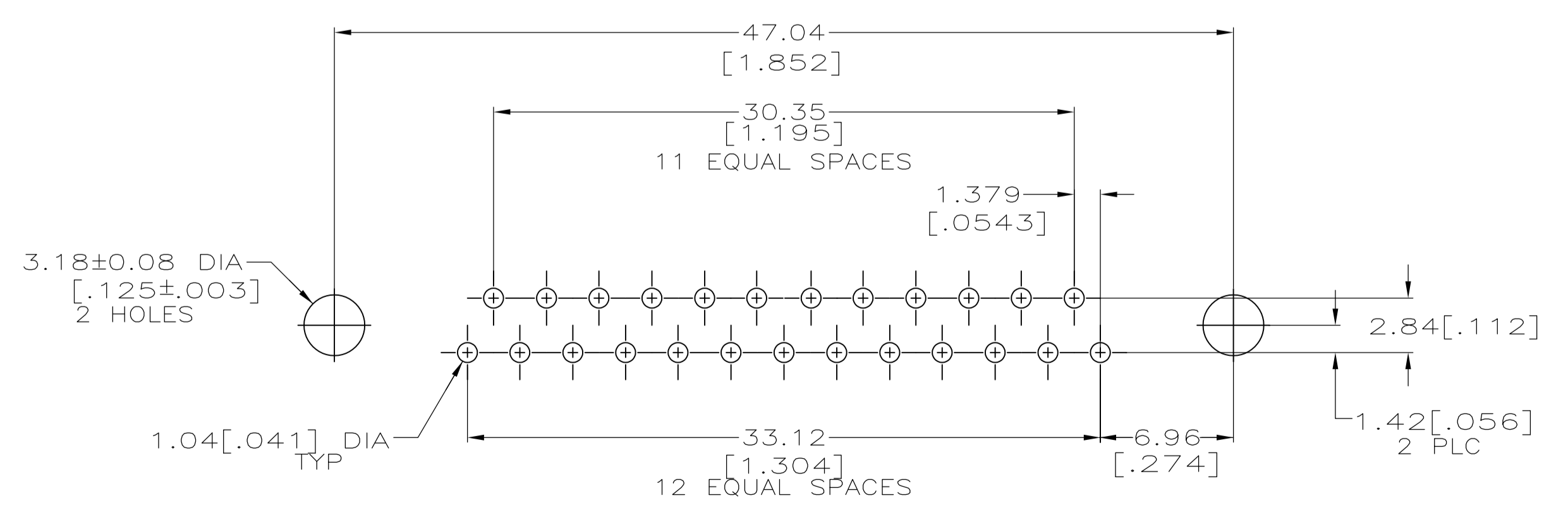

RECOMMENDED P.C. BOARD MOUNTING DIMENSIONS  
P.C. BOARD THICKNESS: 1.57[.062]

SEE DETAIL E	⑥	④	OBSOLETE	6-747842-9
SEE DETAIL D	⑥	④	ACTIVE	6-747842-8
SEE DETAIL E	⑤	③	ACTIVE	6-747842-7
SEE DETAIL E	⑤	④	ACTIVE	747842-6
SEE DETAIL D	⑤	③	ACTIVE	747842-5
SEE DETAIL D	⑤	④	ACTIVE	747842-4
-	⑤	③	-	747842-3
-	⑤	④	-	747842-2
-	⑤	③	-	747842-1
MOUNTING HARDWARE	BOARDLOCK FINISH	CONTACT FINISH	PART STATUS	PART NO

THIS DRAWING IS A CONTROLLED DOCUMENT. DIMENSIONING AND TOLERANCING PER ASME Y14.5M-2009.

DIMENSIONS: mm [INCHES]	TOLERANCES UNLESS OTHERWISE SPECIFIED:	DWG: W.G. LENKER	10-5-89
0 PLC ± -	1 PLC ± -	CHK: R. STONE	2-5-90
2 PLC ± 0.13[.005]	3 PLC ± -	APVD: -	-
4 PLC ± -	ANGLES ± 2°	NAME: -	-

STE TE Connectivity

PLUG ASSEMBLY, SIZE 3, 25 POSITION, RIGHT ANGLE, FRONT METAL SHELL, .318 SERIES, BOARDLOCKS, AMPLIMITE HD-20

PRODUCT SPEC: 108-40025  
APPLICATION SPEC: 114-40010  
SIZE: A1  
CAGE CODE: 00779  
DRAWING NO: 747842  
RESTRICTED TO: -

CUSTOMER DRAWING SCALE: 4:1 SHEET: 1 OF 1 REV: U