

Full-Bridge PWM Motor Driver

FEATURES AND BENEFITS

- ± 1.5 A continuous output current
- 50 V output voltage rating
- 3 to 5.5 V logic supply voltage
- Internal PWM current control
- Fast and slow current decay modes
- Sleep (low current consumption) mode
- Internal transient-suppression diodes
- Internal thermal shutdown circuitry
- Crossover current and UVLO protection

PACKAGES:

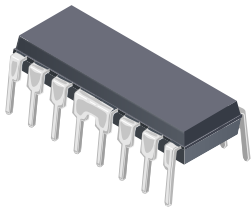

Package B, 16-pin DIP
with exposed tabs

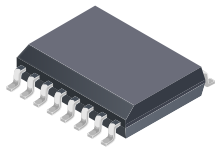

Package LB, 16-pin SOIC
with internally fused pins

Not to scale

DESCRIPTION

Designed for bidirectional pulse-width-modulated (PWM) current control of inductive loads, the A4973 is capable of continuous output currents to ± 1.5 A and operating voltages to 50 V. Internal fixed off-time PWM current control circuitry can be used to regulate the maximum load current to a desired value. The peak load current limit is set by the user's selection of an input reference voltage and external sensing resistor. The fixed off-time pulse duration is set by a user-selected external RC timing network. Internal circuit protection includes thermal shutdown with hysteresis, transient suppression diodes, and crossover current protection. Special power-up sequencing is not required.

With the ENABLE input held low, the PHASE input controls load current polarity by selecting the appropriate source and sink driver pair. The MODE input determines whether the PWM current control circuitry operates in a slow current decay mode (only the selected source driver switching) or in a fast current decay mode (selected source and sink switching). A user-selectable blanking window prevents false triggering of the PWM current control circuitry. With the ENABLE input held high, all output drivers are disabled. A sleep mode is provided to reduce power consumption.

Continued on the next page...

Functional Block Diagram

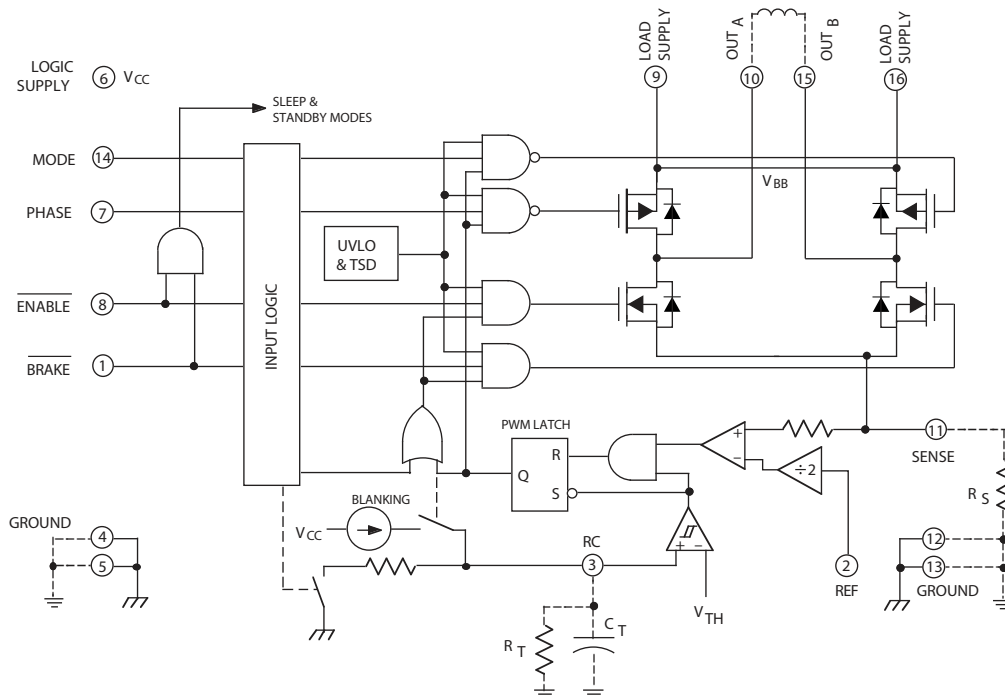

DESCRIPTION (CONTINUED)

When a logic low is applied to the BRAKE input, the braking function is enabled. This overrides ENABLE and PHASE to turn off both source drivers and turn on both sink drivers. The brake function can be used to dynamically brake brush DC motors.

The A4973 is supplied in a choice of two power packages: a 16-pin dual in-line plastic package with copper heat-sink tabs, and a 16-pin plastic SOIC with copper heat-sink tabs. For both package styles, the power tab is at ground potential and needs no electrical isolation. Each package type is available in a lead (Pb) free version (100% matte-tin-plated leadframe).

SELECTION GUIDE

Part Number	Package	Packing
A4973SB-T *	16-pin DIP with exposed thermal tabs	25 pieces per tube
A4973SLBTR-T	16-pin SOICW with internally fused pins	1000 pieces per reel

* A4973SB-T is no longer in production. The device should not be purchased for new design applications. Samples are no longer available. Date of status change: July 2, 2018. For existing customer transition, and for new customers or new applications, use A4973SLBTR-T.

ABSOLUTE MAXIMUM RATINGS

Characteristic	Symbol	Notes	Rating	Units
Load Supply Voltage	V_{BB}		50	V
Logic Supply Voltage	V_{CC}		6	V
Logic/Reference Input Voltage Range	V_{IN}		-0.3 to 6	V
Sense Voltage	V_{SENSE}		0.5	V
Output Current, Continuous	I_{OUT}	Output current rating may be limited by duty cycle, ambient temperature, and heat sinking. Under any set of conditions, do not exceed the specified current rating or a junction temperature of 150°C.	±1.5	A
Transient Output Current	I_{OUT}	$t_W < 2 \mu s$	6	A
Package Power Dissipation	P_D		See graph (p. 3)	W
Operating Ambient Temperature	T_A	Range S	-20 to 85	°C
Maximum Junction Temperature	$T_J(max)$	Fault conditions that produce excessive junction temperature will activate the device's thermal shutdown circuitry. These conditions can be tolerated but should be avoided.	150	°C
Storage Temperature	T_{stg}		-55 to 150	°C

THERMAL CHARACTERISTICS

Characteristic	Symbol	Test Conditions*	Value	Units
Package Thermal Resistance, Junction to Ambient	$R_{\theta JA}$	B Package, single-layer PCB, 1 in ² 2-oz. exposed copper	43	°C/W
		LB Package, 2-layer PCB, 0.3 in ² 2-oz. exposed copper each side	67	°C/W
Package Thermal Resistance, Junction to Tab	$R_{\theta JT}$		6	°C/W

*Additional thermal information available on Allegro website.

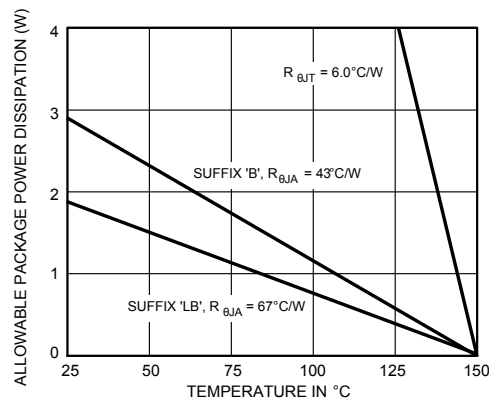

PINOUT DIAGRAM

Note the A4973SB (DIP) and the A4973SLB (SOIC) are electrically identical and share a common terminal number assignment.

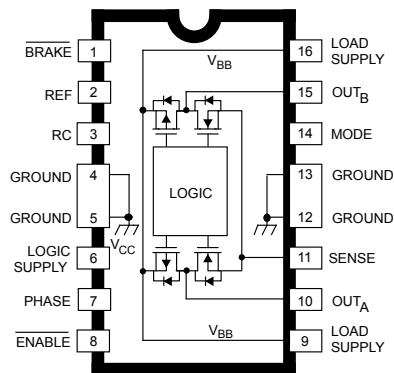

Dwg. PP-056

ELECTRICAL CHARACTERISTICS: Valid at $T_J = 25^\circ\text{C}$, $V_{CC} = 3.0$ to 5.5 V, unless otherwise noted

Characteristic	Symbol	Test Conditions	Min.	Typ.	Max.	Unit
POWER OUTPUTS						
Load Supply Voltage Range	V_{BB}	Operating	5	–	50	V
Output Leakage Current	I_{CEX}	$V_{OUT} = V_{BB}$	–	<1.0	50	μA
		$V_{OUT} = 0$ V	–	<–1.0	–50	μA
Output On Resistance	$R_{DS(on)}$	Total sink and source, $I_{OUT} = 1.5$ A, $V_{BB} > 8$ V, $T_J = 25^\circ\text{C}$	–	1	1.4	Ω
AC TIMING						
PWM RC Fixed Off-time	$t_{OFF RC}$	$C_T = 680$ pF, $R_T = 30$ k Ω , $V_{CC} = 3.3$ V	18.3	20.4	22.5	μs
PWM Minimum On Time	$t_{ON(min)}$	$V_{CC} = 3.3$ V, $R_T \geq 12$ k Ω , $C_T = 680$ pF	0.8	1.4	1.9	μs
		$V_{CC} = 5.0$ V, $R_T \geq 12$ k Ω , $C_T = 470$ pF	0.8	1.6	2.0	μs
Crossover Dead Time	t_{CODT}		–	500	–	ns
Maximum PWM Frequency	$f_{PWM(max)}$	$I_{OUT} = 1.5$ A	70	–	–	kHz
CONTROL CIRCUITRY						
Thermal Shutdown Temperature	T_J		–	165	–	$^\circ\text{C}$
Thermal Shutdown Hysteresis	ΔT_J		–	15	–	$^\circ\text{C}$
UVLO Enable Threshold	V_{UVLO}		2.5	2.75	3.0	V
UVLO Hysteresis	ΔV_{UVLO}		0.12	0.17	0.25	V
Logic Supply Current	$I_{CC(ON)}$	$V_{ENABLE} = V_{IN(0)}$, $V_{BRAKE} = V_{IN(1)}$	–	2.7	3.5	mA
	$I_{CC(Sleep)}$	$V_{ENABLE} = V_{MODE} = V_{BRAKE} = V_{IN(1)}$	–	250	450	μA
Motor Supply Current (No Load)	$I_{BB(ON)}$	$V_{ENABLE} = V_{IN(0)}$	–	500	700	μA
	$I_{BB(Sleep)}$	$V_{ENABLE} = V_{MODE} = V_{BRAKE} = V_{IN(1)}$	–	<1.0	3	μA
Logic Supply Voltage Range	V_{CC}	Operating	3.0	5.0	5.5	V
Logic Input Voltage	$V_{IN(1)}$		$V_{CC} \times 0.55$	–	–	V
	$V_{IN(0)}$		–	–	$V_{CC} \times 0.27$	V
Logic Input Current	$I_{IN(1)}$	$V_{IN} = V_{CC} = 5$ V	–	0	–10	μA
	$I_{IN(0)}$	$V_{IN} = 0$ V, $V_{CC} = 5$ V	–	–106	–200	μA
Reference Input Current	I_{REF}	$V_{REF} = 0$ V to 1 V	–	–	± 5.0	μA
Comparator Input Offset Volt.	V_{IO}	$V_{REF} = 0$ V	–	± 2.0	± 5.0	mV
Reference Input Voltage Range	V_{REF}	REF Pin	0	–	1	V
Gain	A_V	$V_{REF} = 1$ V	1.9	2	2.1	–

FUNCTIONAL DESCRIPTION

Internal PWM Current Control During Forward and Reverse Operation. The A4973 contains a fixed off-time pulse-width-modulated (PWM) current control circuit that can be used to limit the load current to a desired value. The peak value of the current limiting (I_{TRIP}) is set by the selection of an external current sensing resistor (R_S) and reference input voltage (V_{REF}). The internal circuitry compares the voltage across the external sense resistor to the voltage on the reference input terminal (REF) resulting in a transconductance function approximated by:

$$I_{TRIP} \approx \frac{V_{REF}}{2 \times R_S}$$

In forward or reverse mode, the current control circuitry limits the load current as follows: when the load current reaches I_{TRIP} , the comparator resets a latch that turns off the selected source driver or selected sink and source driver pair depending on whether the device is operating in slow or fast current decay mode, respectively.

In slow current decay mode, the selected source driver is disabled and both sinks are turned on. The load inductance causes the current to recirculate through the sink drivers. In fast current decay mode, the selected sink and source driver pair are disabled, then the opposite pair is turned on. The load inductance causes the current to flow from ground to the load supply via the motor winding and the opposite pair of transistors (see figure 1).

Figure 1 — Load-Current Paths

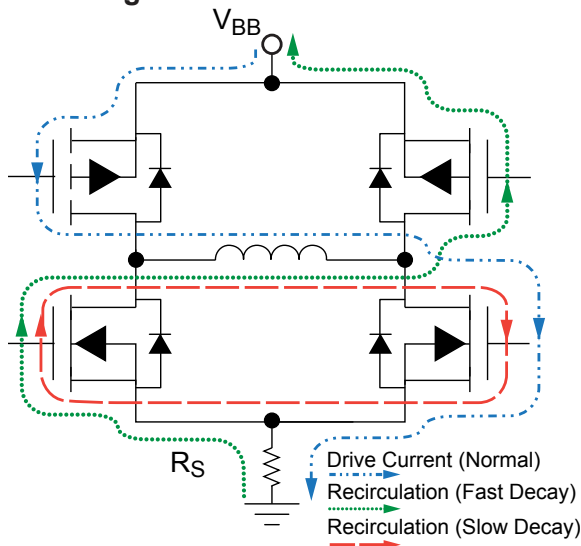

The user selects an external resistor (R_T) and capacitor (C_T) to determine the time period ($t_{OFF} = R_T \times C_T$) during which the drivers remain disabled (see RC Fixed Off-Time section, below). At the end of the RC interval, the drivers are enabled allowing the load current to increase again. The PWM cycle repeats, maintaining the peak load current at the desired value (figure 2).

Figure 2
Fast and Slow Current Decay Waveforms

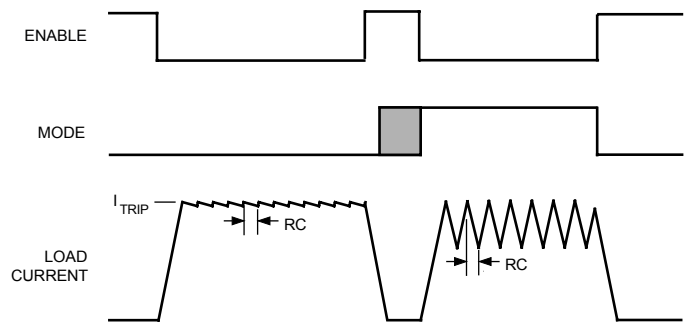

Dwg. WP-015-1

Brake Operation. During braking, care should be taken to ensure that the motor's current does not exceed the ratings of the device. The braking current can be measured by using an oscilloscope with a current probe connected to one of the motor's leads, or if the back-EMF voltage of the motor is known, approximated by:

$$I_{PEAK \text{ BRAKE ML}} \approx \frac{V_{BEMF}}{R_{LOAD}}$$

RC Fixed Off-Time. The internal PWM current control circuitry uses a one-shot to control the time the driver(s) remain(s) off. The one-shot time, t_{OFF} (fixed off-time), is determined by the selection of an external resistor (R_T) and capacitor (C_T) connected in parallel from the RC timing terminal to ground. The fixed off-time, over a range of values of $C_T = 470 \text{ pF}$ to 1500 pF and $R_T = 12 \text{ k}\Omega$ to $100 \text{ k}\Omega$, is approximated by:

$$t_{OFF} \approx R_T \times C_T$$

TRUTH TABLE

BRAKE	ENABLE	PHASE	MODE	OUT_A	OUT_B	DESCRIPTION
H	H	X	H	Off	Off	Sleep Mode
H	H	X	L	Off	Off	Standby
H	L	H	H	H	L	Forward, Fast Current-Decay Mode
H	L	H	L	H	L	Forward, Slow Current-Decay Mode
H	L	L	H	L	H	Reverse, Fast Current-Decay Mode
H	L	L	L	L	H	Reverse, Slow Current-Decay Mode
L	X	X	X	L	L	Brake

X = Don't care.

The operation of the circuit is as follows: when the PWM latch is reset by the current comparator, the voltage on the RC terminal will begin to decay from approximately $0.60 \times V_{CC}$. When the voltage on the RC terminal reaches approximately $0.22 \times V_{CC}$, the PWM latch is set, thereby enabling the driver(s).

RC Blanking. In addition to determining the fixed off-time of the PWM control circuit, the C_T component sets the comparator blanking time. This function blanks the output of the comparator when the outputs are switched by the internal current control circuitry (or by the PHASE, BRAKE, or ENABLE inputs). The comparator output is blanked to prevent false overcurrent detections due to reverse recovery currents of the clamp diodes, and/or switching transients related to distributed capacitance in the load.

During internal PWM operation, at the end of the t_{OFF} time, the comparator's output is blanked and C_T begins to be charged from approximately $0.22 \times V_{CC}$ by an internal current source of approximately 1 mA. The comparator output remains blanked until the voltage on C_T reaches approximately $0.60 \times V_{CC}$.

When a transition of the PHASE input occurs, C_T is discharged to near ground during the crossover delay time (the crossover delay time is present to prevent simultaneous conduction of the source and sink drivers). After the crossover delay, C_T is charged by an internal current source of approximately 1 mA. The comparator output remains blanked until the voltage on C_T reaches approximately $0.60 \times V_{CC}$.

When the device is disabled, via the ENABLE input, C_T is discharged to near ground. When the device is re-enabled, C_T is charged by an internal current source of approximately 1 mA. The comparator output remains blanked until the voltage on C_T reaches approximately $0.60 \times V_{CC}$.

For 3.3 V operation, the minimum recommended value for C_T is 680 pF \pm 5%. For 5.0 V operation, the minimum recommended value for C_T is 470 pF \pm 5%. These values ensure that the blanking time is sufficient to avoid false trips of the comparator under normal operating conditions. For optimal regulation of the load current, the above values for C_T are recommended and the value of R_T can be sized to determine t_{OFF} . For more information regarding load current regulation, see below.

LOAD CURRENT REGULATION WITH INTERNAL PWM CURRENT CONTROL CIRCUITRY

When the device is operating in slow current decay mode, there is a limit to the lowest level that the PWM current control circuitry can regulate load current. The limitation is the minimum duty cycle, which is a function of the user-selected value of t_{OFF} and the minimum on-time pulse $t_{ON(min)max}$ that occurs each time the PWM latch is reset. If the motor is not rotating (as in the case of a stepper motor in hold/detent mode, a brush DC motor when stalled, or at startup), the worst-case value of current regulation can be approximated by:

$$I_{AVE} \approx \frac{\{ [V_{BB} - (2 \times I \times R_{DS})] \times t_{ON(min)max} \} - [1.05 (I \times R_{DS} + V_F) \times t_{OFF}]}{1.05 \times (t_{ON(min)max} + t_{OFF}) \times R_{LOAD}}$$

where $t_{OFF} = R_T \times C_T$, R_{LOAD} is the series resistance of the load, V_{BB} is the motor supply voltage and $t_{ON(min)max}$ is specified in the Electrical Characteristics table. When the motor is rotating, the back EMF generated will influence the above relationship. For brush DC motor applications, the current regulation is improved. For stepper motor applications, when the motor is rotating, the effect is more complex. A discussion of this subject is included in the section on stepper motors below.

The following procedure can be used to evaluate the worst-case slow current decay internal PWM load current regulation in the system:

1. Set V_{REF} to 0 volts. With the load connected and the PWM current control operating in slow current decay mode, use an oscilloscope to measure the time the output is low (sink on) for the output that is chopping. This is the typical minimum on time ($t_{ON(min)typ}$) for the device.
2. The C_T then should be increased until the measured value of $t_{ON(min)}$ is equal to $t_{ON(min)max}$ as specified in the electrical characteristics table.
3. When the new value of C_T has been set, the value of R_T should be decreased so the value for $t_{OFF} = R_T \times C_T$ (with the artificially increased value of C_T) is equal to the nominal design value.
4. The worst-case load-current regulation then can be measured in the system under operating conditions.

PWM of the PHASE and ENABLE Inputs. The PHASE and ENABLE inputs can be pulse-width modulated to regulate load current. If the internal PWM current control is used, the comparator blanking function is active during phase and enable transitions. This eliminates false tripping of the over-current comparator caused by switching transients (see RC Blanking section, above).

Enable PWM. With the MODE input low, toggling the ENABLE input turns on and off the selected source and sink drivers. The corresponding pair of intrinsic flyback and ground-clamp diodes conduct after the drivers are disabled, resulting in fast current decay. When the device is enabled the internal current control circuitry will be active and can be used to limit the load current in a slow current decay mode.

For applications that PWM the ENABLE input and desire the internal current limiting circuit to function in the fast decay mode, the ENABLE input signal should be inverted and connected to the MODE input. This prevents the device from being switched into sleep mode when the ENABLE input is low.

Phase PWM. Toggling the PHASE terminal selects which sink/source pair is enabled, producing a load current that varies with the duty cycle and remains continuous at all times. This can have added benefits in bidirectional brush DC servo motor applications as the transfer function between the duty cycle on the PHASE input and the average voltage applied to the motor is more linear than in the case of ENABLE PWM control (which produces a discontinuous current at low current levels). For more information see DC Motor Applications section, below.

Synchronous Fixed-Frequency PWM. The internal PWM current-control circuitry of multiple A4973 devices can be synchronized by using the simple circuit shown in figure 3. A 555 IC can be used to generate the reset pulse/blanking signal (t_1) for the device and the period of the PWM cycle (t_2). The value of t_1 should be a minimum of 1.5 ms. When used in this configuration, the R_T and C_T components should be omitted. The PHASE and ENABLE inputs should not be PWMed with this circuit configuration due to the absence of a blanking function synchronous with their transitions.

Miscellaneous Information. A logic high applied to both the ENABLE and MODE terminals puts the device into a sleep mode to minimize current consumption when not in use.

An internally generated dead time prevents crossover currents that can occur when switching phase or braking.

Thermal protection circuitry turns off all drivers should the

junction temperature reach 165°C (typical). This is intended only to protect the device from failures due to excessive junction temperatures and should not imply that output short circuits are permitted. The hysteresis of the thermal shutdown circuit is approximately 15°C.

APPLICATION NOTES

Current Sensing. The actual peak load current (I_{PEAK}) will be above the calculated value of I_{TRIP} due to delays in the turn off of the drivers. The amount of overshoot can be approximated by:

$$I_{OS} \approx \frac{(V_{BB} - [(I_{TRIP} \times R_{LOAD}) + V_{BEMF}]) \times t_{PWM(OFF)}}{L_{LOAD}}$$

where V_{BB} is the motor supply voltage, V_{BEMF} is the back-EMF voltage of the load, R_{LOAD} and L_{LOAD} are the resistance and inductance of the load respectively, and $t_{PWM(OFF)}$ is specified in the electrical characteristics table.

The reference terminal has a maximum input bias current of $\pm 5 \mu A$. This current should be taken into account when determining the impedance of the external circuit that sets the reference voltage value.

To minimize current-sensing inaccuracies caused by ground trace $I \times R$ drops, the current-sensing resistor should have a separate return to the ground terminal of the device. For low-value sense resistors, the $I \times R$ drops in the printed wiring board can be significant and should be taken into account. The use of sockets should be avoided as their contact resistance can cause variations in the effective value of R_S .

Generally, larger values of R_S reduce the aforementioned effects but can result in excessive heating and power loss in the sense resistor. The selected value of R_S should not cause the absolute maximum voltage rating of 500 mV, for the SENSE terminal, to be exceeded.

FIGURE 3
SYNCHRONOUS FIXED-FREQUENCY CONTROL CIRCUIT

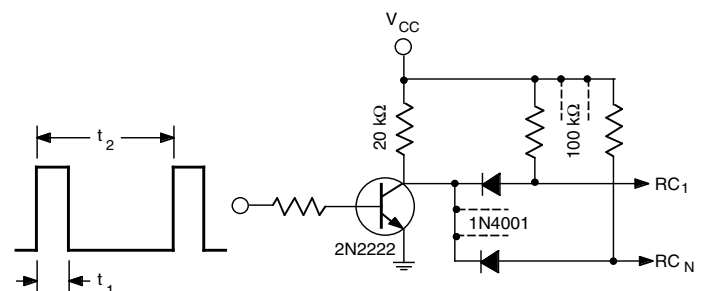

Dwg. EP-060

The current-sensing comparator functions down to ground allowing the device to be used in microstepping, sinusoidal, and other varying current-profile applications.

Thermal Considerations. For reliable operation, it is recommended that the maximum junction temperature be kept below 110°C to 125°C. The junction temperature can be measured best by attaching a thermocouple to the power tab/batwing of the device and measuring the tab temperature, T_{TAB} . The junction temperature can then be approximated by using the formula:

$$T_J \approx T_{TAB} + I_{LOAD}^2 \times R_{DS(on)} \times R_{\theta JT}$$

The value for $R_{\theta JT}$ is given in the package thermal resistance table for the appropriate package.

The power dissipation of the batwing packages can be improved by 20% to 30% by adding a section of printed circuit board copper (typically 6 to 18 square centimeters) connected to the batwing terminals of the device.

PCB Layout. The load supply terminal, V_{BB} , should be decoupled with an electrolytic capacitor (>47 μ F is recommended) placed as close to the device as is physically practical. To minimize the effect of system ground $I \times R$ drops on the logic and reference input signals, the system ground should have a low-resistance return to the motor supply voltage. See also the Current Sensing and Thermal Considerations sections, above.

Fixed Off-Time Selection. With increasing values of t_{OFF} , switching losses will decrease, low-level load-current regulation will improve, EMI will be reduced, the PWM frequency will decrease, and ripple current will increase. The value of t_{OFF} can be chosen for optimization of these parameters. For applications where audible noise is a concern, typical values of t_{OFF} are chosen to be in the range of 15 to 35 μ s.

Stepper Motor Applications. The MODE terminal can be used to optimize the performance of the device in microstepping/sinusoidal stepper motor drive applications. When the load current is increasing, slow decay mode is used to limit the switching losses in the device and iron losses in the motor. This also improves the maximum rate at which the load current can increase (as compared to fast decay) due to the slow rate of decay during t_{OFF} . When the load current is decreasing, fast decay mode is used to regulate the load current to the desired level. This prevents tailing of the current profile caused by the back-EMF voltage of the stepper motor.

In stepper motor applications applying a constant current to the load, slow decay mode PWM is typically used to limit the switching losses in the device and iron losses in the motor.

DC Motor Applications. In closed-loop systems, the speed of a DC motor can be controlled by PWM of the PHASE or ENABLE inputs, or by varying the reference input voltage (REF). In digital systems (microprocessor controlled), PWM of the PHASE or ENABLE input is used typically thus avoiding the need to generate a variable analog voltage reference. In this case, a DC voltage on the REF input is used typically to limit the maximum load current.

In DC servo applications, which require accurate positioning at low or zero speed, PWM of the PHASE input is selected typically. This simplifies the servo control loop because the transfer function between the duty cycle on the PHASE input and the average voltage applied to the motor is more linear than in the case of ENABLE PWM control (which produces a discontinuous current at low current levels).

With bidirectional DC servo motors, the PHASE terminal can be used for mechanical direction control. Similar to when braking the motor dynamically, abrupt changes in the direction of a rotating motor produces a current generated by the back EMF. The current generated will depend on the mode of operation. If the internal current control circuitry is not being used, then the maximum load current generated can be approximated by $I_{LOAD} = (V_{BEMF} + V_{BB}) / R_{LOAD}$ where V_{BEMF} is proportional to the motor's speed. If the internal slow current decay control circuitry is used, then the maximum load current generated can be approximated by $I_{LOAD} = V_{BEMF} / R_{LOAD}$. For both cases care must be taken to ensure that the maximum ratings of the device are not exceeded. If the internal fast current decay control circuitry is used, then the load current will regulate to a value given by:

$$I_{LOAD} = V_{REF} / (R_S \times 2)$$

CAUTION: In fast current decay mode, when the direction of the motor is changed abruptly, the kinetic energy stored in the motor and load inertia will be converted into current that charges the V_{BB} supply bulk capacitance (power supply output and decoupling capacitance). Care must be taken to ensure that the capacitance is sufficient to absorb the energy without exceeding the voltage rating of any devices connected to the motor supply. See also the Brake Operation section, above.

Soldering Considerations. The lead (Pb) free (100% matte tin) plating on lead terminations is 100% backward-compatible for use with traditional tin-lead solders of any composition, at any temperature of soldering that has been traditionally used for that tin-lead solder alloy. Further, 100% matte-tin finishes solder well with tin-lead solders even at temperatures below 232°C. This is because the matte tin dissolves easily in the tin-lead. Additional information on soldering is available on the Allegro website, www.allegromicro.com.

FIGURE 4 — TYPICAL APPLICATION

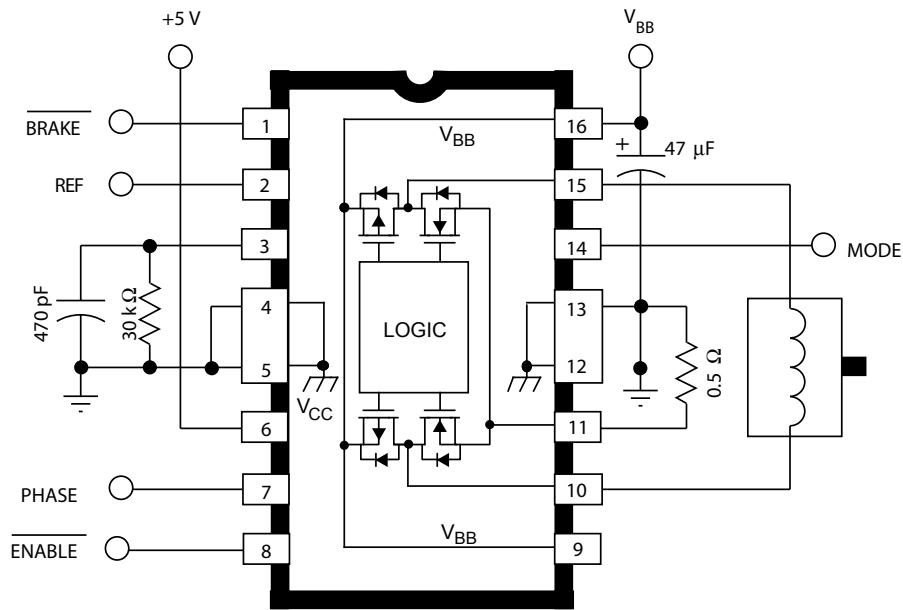

B package 16-pin DIP

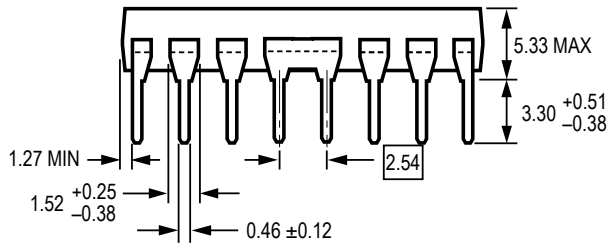
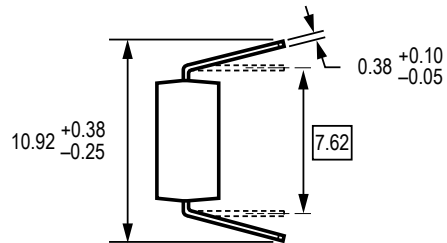
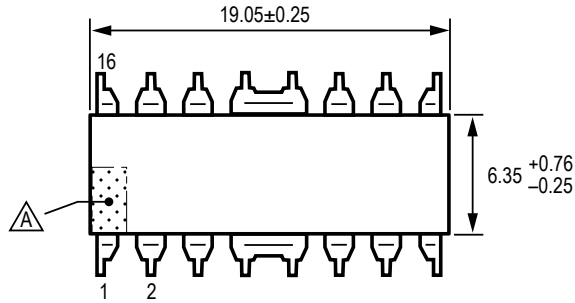

For Reference Only
(reference JEDEC MS-001 BB)

Dimensions in millimeters

Dimensions exclusive of mold flash, gate burrs, and dambar protrusions

Exact case and lead configuration at supplier discretion within limits shown

A Terminal #1 mark area

LB package 16-pin SOICW

For Reference Only – Not for Tooling Use

(Reference Allegro DWG-0000388, Rev. 1 and JEDEC MS-013AA)

NOT TO SCALE

Dimensions in millimeters

Dimensions exclusive of mold flash, gate burrs, and dambar protrusions
Exact case and lead configuration at supplier discretion within limits shown

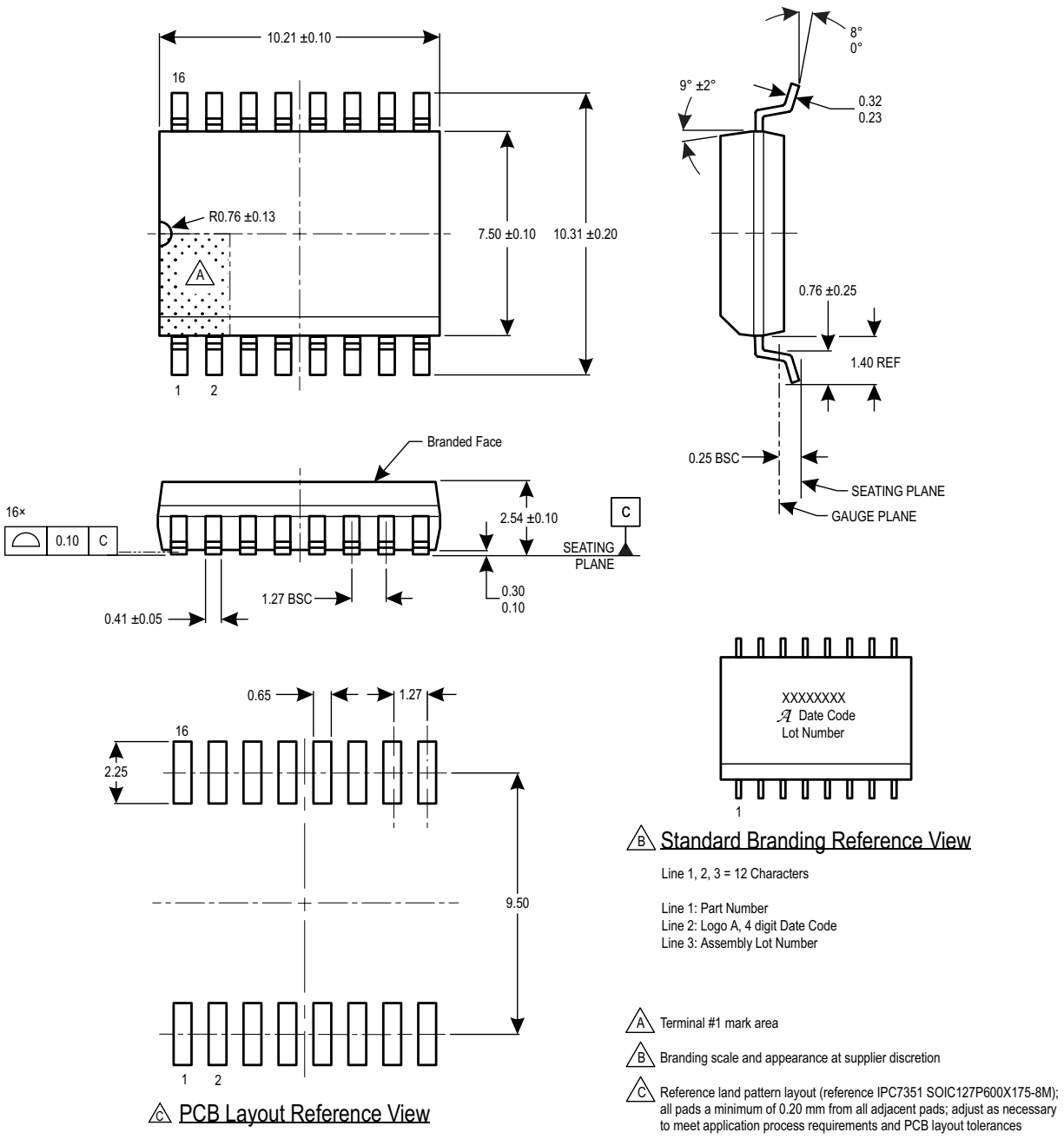

Revision History

Number	Date	Description
1	October 23, 2012	Update Absolute Maximum Ratings
2	June 5, 2017	Updated product offerings
3	January 8, 2018	Updated A4973SB-T product status
4	July 2, 2018	Updated A4973SB-T product status to LTB
5	January 29, 2019	Updated A4973SB-T product status to obsolete
6	February 3, 2020	Minor editorial updates
7	January 31, 2022	Updated LB package drawing (page 12)

Copyright 2022, Allegro MicroSystems.

Allegro MicroSystems reserves the right to make, from time to time, such departures from the detail specifications as may be required to permit improvements in the performance, reliability, or manufacturability of its products. Before placing an order, the user is cautioned to verify that the information being relied upon is current.

Allegro's products are not to be used in any devices or systems, including but not limited to life support devices or systems, in which a failure of Allegro's product can reasonably be expected to cause bodily harm.

The information included herein is believed to be accurate and reliable. However, Allegro MicroSystems assumes no responsibility for its use; nor for any infringement of patents or other rights of third parties which may result from its use.

Copies of this document are considered uncontrolled documents.

For the latest version of this document, visit our website:

www.allegromicro.com