



FEATURES:

- Efficiency up to 90%
- Ultra-wide 4:1 Input range
- No-load consumption $\leq 0.14W$
- Operating Temperature: $-40^{\circ}C$ to $+75^{\circ}C$
- Input under voltage lockout
- On/Off Remote Control
- Over Voltage Protection
- I/Output Isolation 1500VDC
- Over Current protection
- Continuous Short Circuit protection

Models Single output



Model	Input Voltage (VDC)	Max Input current Full/No load (mA)	Output Voltage (VDC)	Output Current max (mA)	Isolation (VDC)	Max Capacitive Load(μF)	Efficiency (%)
AM30EW-2403S-NZ	9-36‡	993/100	3.3	6000	1500	10000	85
AM30EW-2405S-NZ	9-36‡	1453/100	5	6000	1500	10000	88
AM30EW-2409S-NZ	9-36‡	1488/12	9	3333	1500	4700	88
AM30EW-2412S-NZ	9-36‡	1488/12	12	2500	1500	2700	90
AM30EW-2415S-NZ	9-36‡	1488/12	15	2000	1500	1680	90
AM30EW-2424S-NZ	9-36‡	1488/12	24	1250	1500	680	90
AM30EW-4803S-NZ	18-75	485/30	3.3	6000	1500	10000	87
AM30EW-4805S-NZ	18-75	726/35	5	6000	1500	10000	88
AM30EW-4812S-NZ	18-75	744/10	12	2500	1500	2700	89
AM30EW-4815S-NZ	18-75	744/10	15	2000	1500	1680	89
AM30EW-4824S-NZ	18-75	744/10	24	1250	1500	680	89

Dual output

Model	Input Voltage (VDC)	Max Input current Full/No load (mA)	Output Voltage (VDC)	Output Current max (mA)	Isolation (VDC)	Max Capacitive Load(μF)	Efficiency (%)
AM30EW-2405D-NZ	9-36‡	1453/100	± 5	± 3000	1500	2000	86
AM30EW-2412D-NZ	9-36‡	1488/12	± 12	± 1250	1500	1250	89
AM30EW-2415D-NZ	9-36‡	1488/12	± 15	± 1000	1500	680	89
AM30EW-2424D-NZ	9-36‡	1488/12	± 24	± 625	1500	470	89
AM30EW-4805D-NZ	18-75	726/35	± 5	± 3000	1500	2000	86
AM30EW-4812D-NZ	18-75	744/10	± 12	± 1250	1500	1250	88
AM30EW-4815D-NZ	18-75	744/10	± 15	± 1000	1500	680	88

‡ At Input range 9-18VDC output power will be rated at 80%.

*Add suffix “-ST” for optional screw terminal bottom plate or “-STD” for optional DIN Rail screw terminal bottom plate.

**Add suffix “-K” for optional heatsink, “-K-ST” for optional heatsink and screw terminal bottom plate or “-K-STD” for optional heatsink and DIN Rail screw terminal bottom plate.

NOTE: All specifications in this datasheet are measured at an ambient temperature of $25^{\circ}C$, humidity $< 75\%$, nominal input voltage and at rated output load unless otherwise specified.

Input Specifications

Parameters	Nominal	Typical	Maximum	Units
Voltage range	24 48	9-36 18-75		VDC
Filter	π (Pi) Network			
Startup time		10		ms
Absolute Maximum Rating (1sec max)	24 48		-0.7-50 -0.7-100	VDC
On/Off control	ON – open or 3.5-12VDC ; OFF – short to $-V_{in}$ or 0-1.2VDC, Idle current: 5 - 8mA			
Input under voltage lockout	24 48		5.5-6.5 12-15.5	VDC
Input reflected current		40		mA

Isolation Specifications

Parameters	Conditions	Typical	Maximum	Units
Tested I/O voltage	60 sec, 1mA	1500		VDC
Resistance	500VDC Isolation	>1000		MOhm
Capacitance	I/O 100KHz/0.1V	2000		pF

Output Specifications

Parameters	Conditions	Typical	Maximum	Units	
Voltage accuracy		±1	±3	%	
Over voltage protection	Zener Diode Clamp	110	160	%	
Over current protection		110	190	% of Io	
Short Circuit protection	Continuous, hiccup				
Short circuit restart	Auto-Recovery				
Line voltage regulation	Full load, LL-HL	Positive output	±0.2	±0.5	% of Vin
		Negative output	±0.5	±1	
Load voltage regulation	0% to 100% load	Positive output	±0.5	±1	%
		Negative output	±0.5	±1.5	
Temperature coefficient			±0.03	%/°C	
Ripple & Noise	20MHz Bandwidth, 100% load	Single output	50	100	mV p-p
		Dual output	50	150	
Voltage adjustment range			±10	%	
Transient recovery time	25% load step change	300	500	µS	
Transient recovery deviation	25% load step change: 3.3, 5, ±5Vout	±5	±8	%	
	25% load step change: others	±3	±5		

General Specifications

Parameters	Conditions	Typical	Maximum	Units
Switching frequency	100% load	300		KHz
Operating temperature	See derating curve	-40 to +80		°C
Storage temperature		-55 to +125		°C
Maximum case temperature			100	°C
Cooling	Free air convection			
Humidity			95	% RH
Case material	Aluminum Alloy			
Weight	Pin mountable	26		g
	With optional -ST mounting plate:	48		
	With optional -STD mounting plate:	68		
	With optional -K Pin mountable	34		
	With optional -ST-K mounting plate:	56		
	With optional -STD-K mounting plate:	76		
Dimensions (L x W x H)	Pin mountable	2.00 x 1.00 x 0.46 inches	50.80 x 25.40 x 11.80 mm	
	With optional -ST mounting plate:	2.99 x 1.24 x 0.84 inches	76.00 x 31.50 x 21.20 mm	
	With optional -STD mounting plate:	2.99 x 1.24 x 1.00 inches	76.00 x 31.50 x 25.30 mm	
	With optional -K Pin mountable	2.02 x 1.03 x 0.65 inches	51.40 x 26.20 x 16.50 mm	
	With optional -ST-K mounting plate:	2.99 x 1.24 x 1.02 inches	76.00 x 31.50 x 25.80 mm	
	With optional -STD-K mounting plate:	2.99 x 1.24 x 1.18 inches	76.00 x 31.50 x 29.90 mm	
MTBF	>1,000,000 hours (MIL-HDBK -217F, Ground Benign, t=+25°C)			
Maximum soldering temperature	1.5mm from case for 10 sec		300	°C

Environment Specification

Test	Parameters	Conditions
Vibration	Test mode	10-55Hz
	Acceleration	10g, 30min, every axis tested

Safety Specifications

Parameters		
Approval	EN62368-1 , UL60950-1 with exception of the dual output models	
Standards	CISPR32/EN 55032, Class A(Bare component), Class B, with EMC recommended circuit	
	Electrostatic Discharge Immunity	IEC 61000-4-2, Contact ± 4 KV, Criteria B
	RF, Electromagnetic Field Immunity	IEC 61000-4-3, 10V/m, Criteria A
Electrical Fast Transient / Burst Immunity	Single output	IEC 61000-4-4, ± 2 KV, Criteria B, with external filter
	Dual output	IEC 61000-4-4, ± 2 KV, Criteria B, with external filter
Surge Immunity	Single output	IEC 61000-4-5, ± 2 KV, Criteria B, with external filter
	Dual output	IEC 61000-4-5, ± 2 KV, Criteria B, with external filter
RF, Conducted Disturbance Immunity	Single output	IEC 61000-4-6, 3Vrms, Criteria A
	Dual output	IEC 61000-4-6, 10Vrms, Criteria A

Dimensions

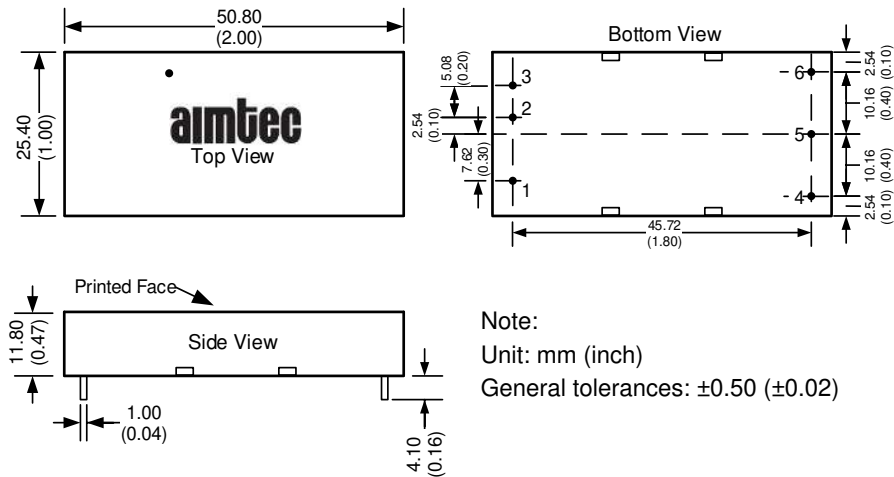

Pin Out Specifications

Pin	Single	Dual
1	On/Off Control	On/Off Control
2	-Vin	-Vin
3	+Vin	+Vin
4	Trim	-Vout
5	-Vout	Common
6	+Vout	+Vout

Heatsink Option: AM30EW-NZ-K

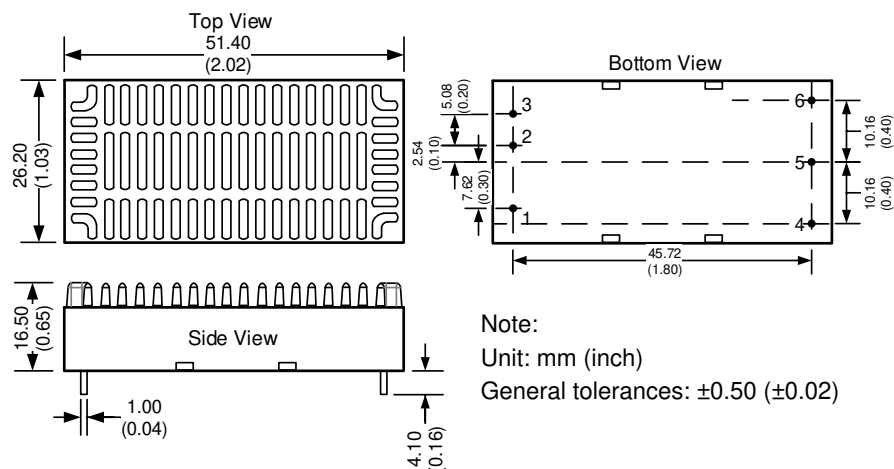

Screw Terminal Option: AM30EW-NZ-ST

Pin Out Specifications

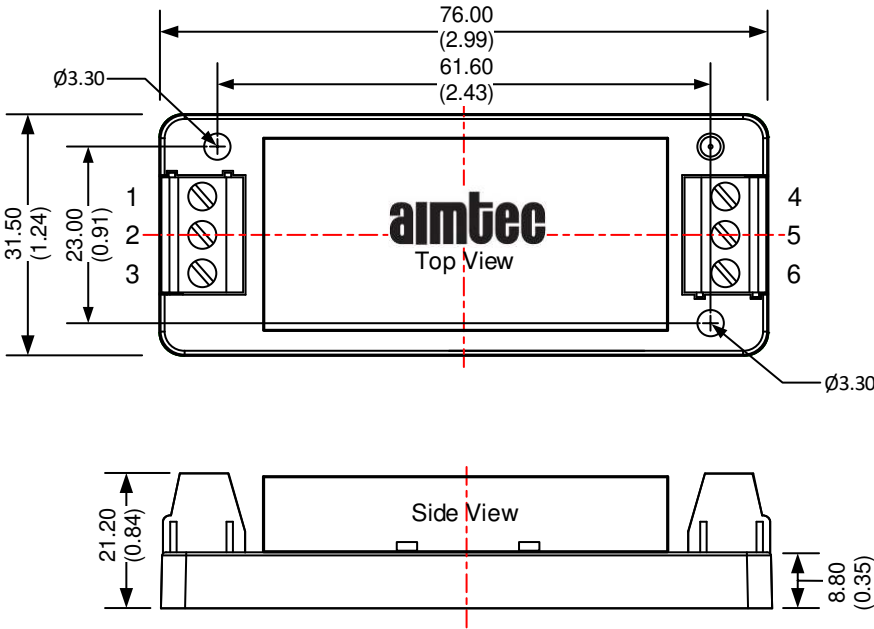

Pin	Single	Dual
1	On/Off Control	On/Off Control
2	-Vin	-Vin
3	+Vin	+Vin
4	Trim	- Vout
5	- Vout	Common
6	+ Vout	+ Vout

Note:
Unit: mm (inch)
Wire range: 24-12 AWG
Tightening torque: Max 0.4 N*m
General tolerances: ± 0.50 (± 0.02)

Screw Terminal with Heatsink Option: AM30EW-NZ-K-ST

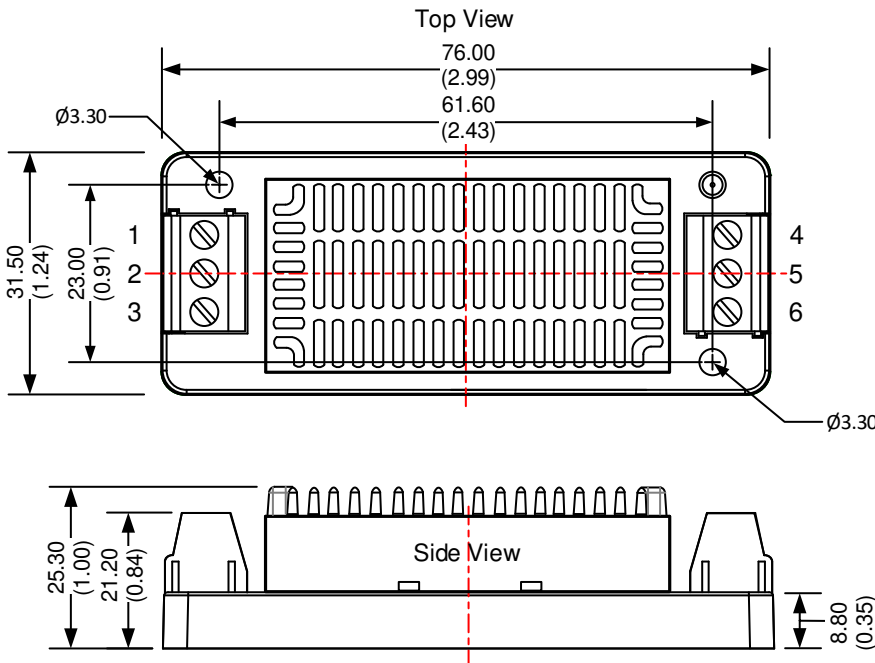

Note:
Unit: mm (inch)
Wire range: 24-12 AWG
Tightening torque: Max 0.4 N*m
General tolerances: ± 0.50 (± 0.02)

DIN-RAIL Option: AM30EW-NZ-K-STD

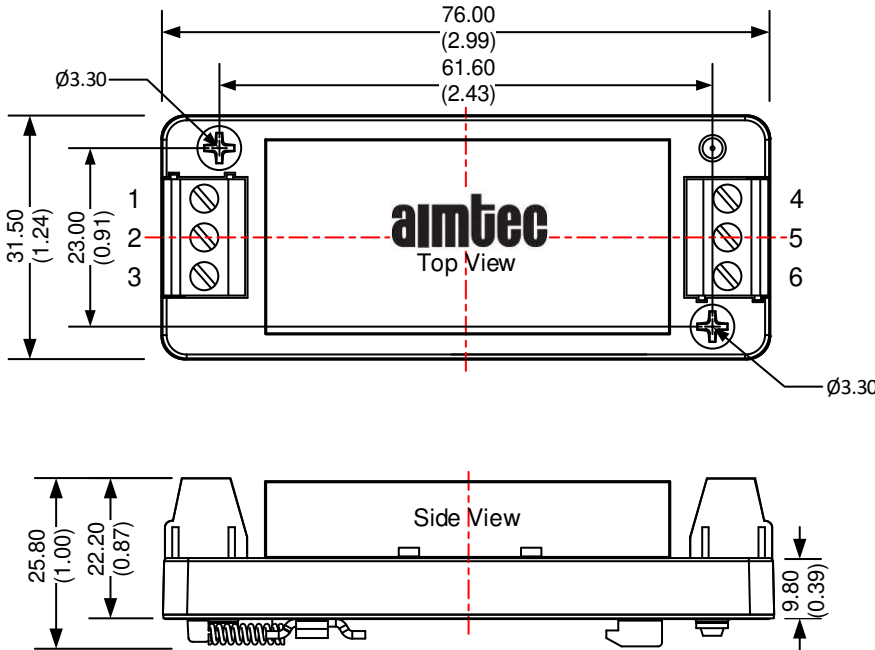

Pin Out Specifications

Pin	Single	Dual
1	On/Off Control	On/Off Control
2	-Vin	-Vin
3	+Vin	+Vin
4	Trim	- Vout
5	- Vout	Common
6	+ Vout	+ Vout

Note:
Unit: mm (inch)
Mounting rail: TS35
Wire range: 24-12 AWG
Tightening torque: Max 0.4 N*m
General tolerances: ± 0.50 (± 0.02)

DIN-RAIL with heatsink Option: AM30EW-NZ-K-STD

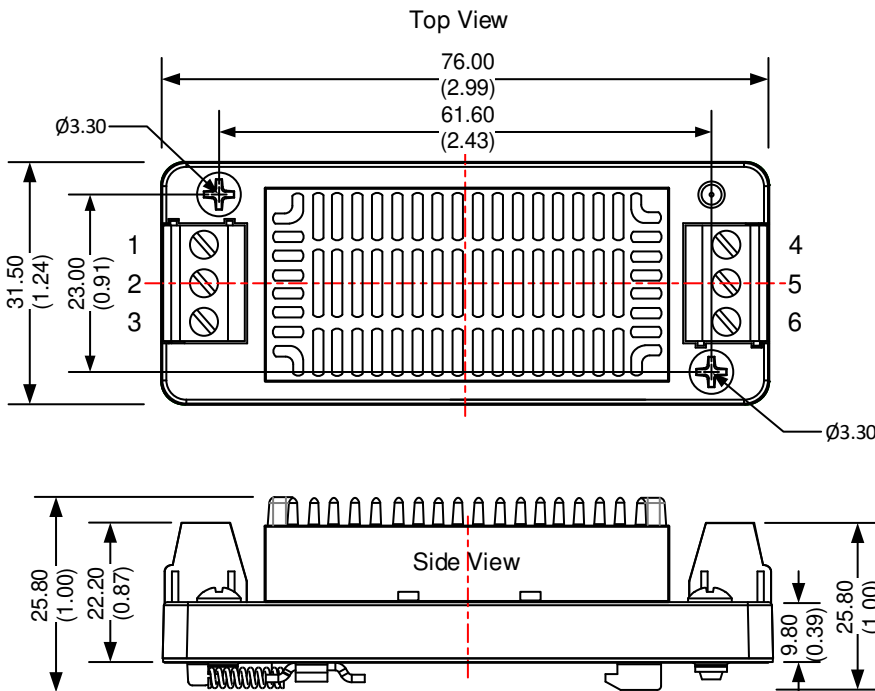

Note:
Unit: mm (inch)
Mounting rail: TS35
Wire range: 24-12 AWG
Tightening torque: Max 0.4 N*m
General tolerances: ± 0.50 (± 0.02)

Derating

Single output: 3.3V/5VDC output

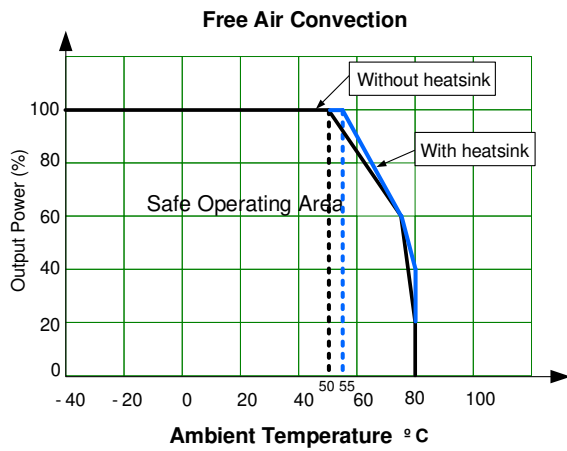

Single output: 9V/12V/15V/24VDC output

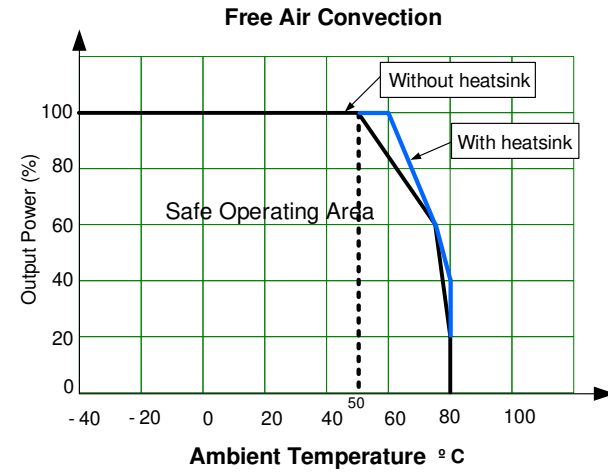

Dual output:

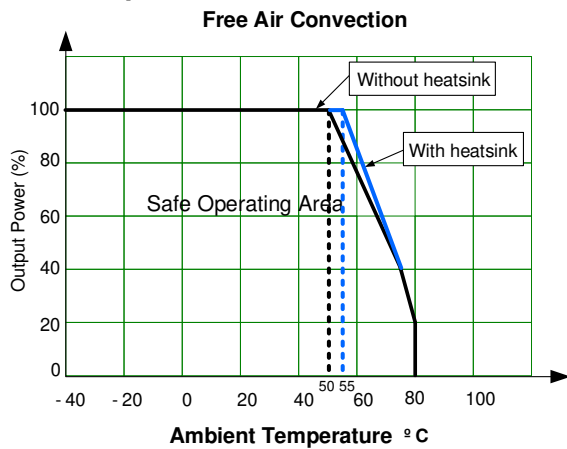

NOTE: With operations at 12V nominal input (9-18VDC) the output power will be rated at 80% only.

Typical application circuit

Single output models

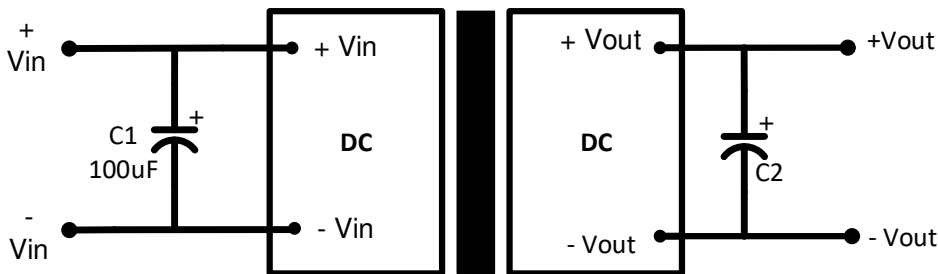

Dual output models

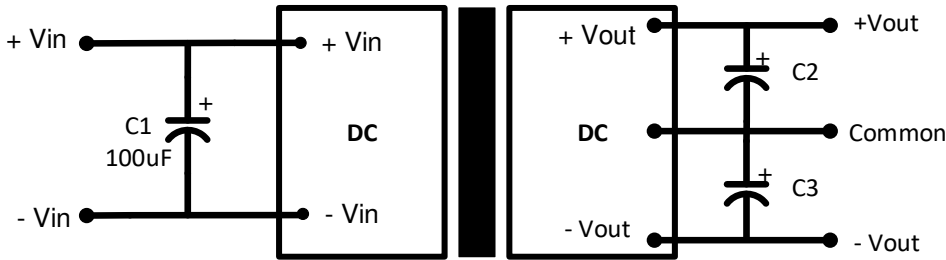

Model	Single output models		Dual output models	
	3.3V/5V/9V Vout	12V/15V/24V Vout	±5V/±12V/±15V Vout	±24V Vout
C2, C3	220µF	100µF	220µF	100µF

EMC recommended external filter

Single output models

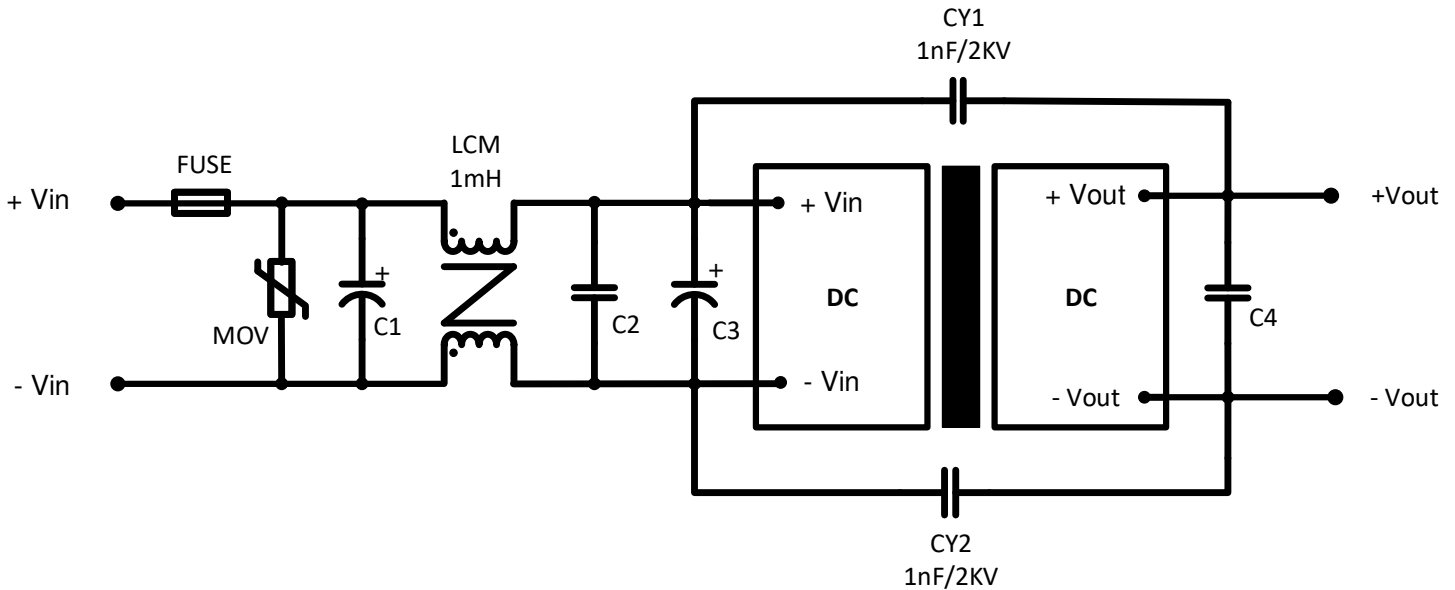

Model	24V Vin	48V Vin
FUSE	Choose based on actual input current	
MOV	S20K30	S14K60
C1	680µF/50V	330µF/100V
C2	4.7µF/50V	2.2µF/100V
C3	330µF/50V	330µF/100V
C4	Refer to the C2 in typical application circuit	

Dual output models

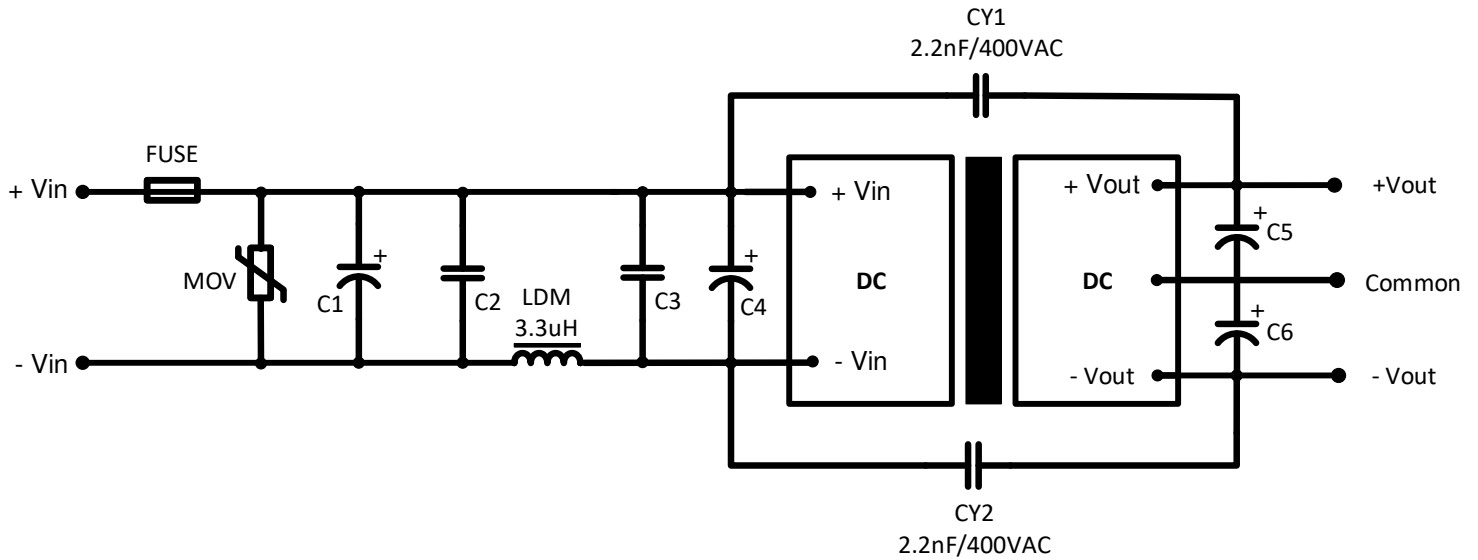

Model	24V Vin	48V Vin
FUSE	Choose based on actual input current	
MOV	S20K30	S14K60
C1	680μF/50V	330μF/100V
C2, C3	2.2μF/50V	2.2μF/100V
C4	330μF/50V	330μF/100V
C5	Refer to the C2 in typical application circuit	

Trimming

Output voltage can be externally trimmed by utilizing the methods as shown below

Fixed Resistor

Variable Potentiometer

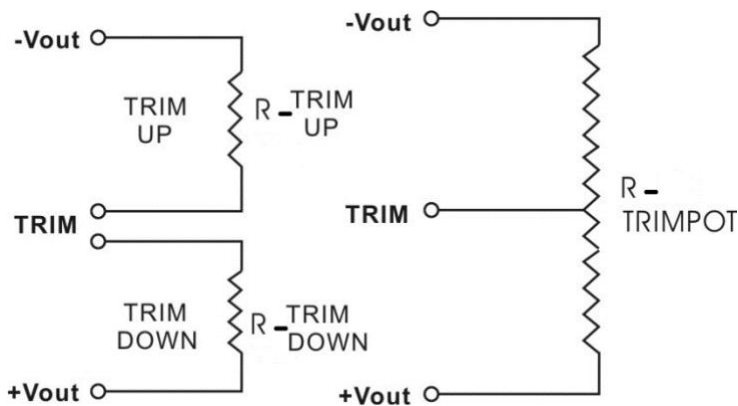

Leave open if not used.

AM30EW-xx03S-NZ

Trim down %	1	2	3	4	5	6	7	8	9	10
Vout (VDC)	3.267	3.234	3.201	3.168	3.135	3.102	3.069	3.036	3.003	2.97
Rt down (KΩ)	193.344	106.818	70.696	50.870	38.341	29.708	23.397	18.583	14.790	11.724
Trim up %	1	2	3	4	5	6	7	8	9	10
Vout (VDC)	3.333	3.366	3.399	3.432	3.465	3.498	3.531	3.564	3.597	3.63
Rt up (KΩ)	305.949	102.749	57.886	38.180	27.104	20.007	15.072	11.442	8.658	6.457

AM30EW-xx05S-NZ

Trim down %	1	2	3	4	5	6	7	8	9	10
Vout (VDC)	4.95	4.9	4.85	4.8	4.75	4.7	4.65	4.6	4.55	4.5
Rt down (KΩ)	105.181	52.154	31.997	21.378	14.823	10.373	7.155	4.719	2.811	1.277
Trim up %	1	2	3	4	5	6	7	8	9	10
Vout (VDC)	5.05	5.1	5.15	5.2	5.25	5.3	5.35	5.4	5.45	5.5
Rt up (KΩ)	176.356	71.279	41.974	28.200	20.198	14.967	11.281	8.544	6.430	4.749

AM30EW-xx09S-NZ

Trim down %	1	2	3	4	5	6	7	8	9	10
Vout (VDC)	8.91	8.82	8.73	8.64	8.55	8.46	8.37	8.28	8.19	8.1
Rt down (KΩ)	375.533	207.430	139.157	102.145	78.924	62.997	51.393	42.562	35.617	30.011
Trim up %	1	2	3	4	5	6	7	8	9	10
Vout (VDC)	9.09	9.18	9.27	9.36	9.45	9.54	9.63	9.72	9.81	9.9
Rt up (KΩ)	314.532	112.639	64.148	42.357	29.975	21.990	16.412	12.297	9.134	6.629

AM30EW-xx12S-NZ

Trim down %	1	2	3	4	5	6	7	8	9	10
Vout (VDC)	11.88	11.76	11.64	11.52	11.4	11.28	11.16	11.04	10.92	10.8
Rt down (KΩ)	496.092	301.452	212.527	161.585	128.573	105.442	88.332	75.164	64.716	56.223
Trim up %	1	2	3	4	5	6	7	8	9	10
Vout (VDC)	12.12	12.24	12.36	12.48	12.6	12.72	12.84	12.96	13.08	13.2
Rt up (KΩ)	706.435	158.920	83.879	54.075	38.077	28.095	21.274	16.317	12.552	9.595

AM30EW-xx15S-NZ

Trim down %	1	2	3	4	5	6	7	8	9	10
Vout (VDC)	14.85	14.7	14.55	14.4	14.25	14.1	13.95	13.8	13.65	13.5
Rt down (KΩ)	634.883	400.637	288.514	222.759	179.537	148.960	126.187	108.569	94.532	83.087
Trim up %	1	2	3	4	5	6	7	8	9	10
Vout (VDC)	15.15	15.3	15.45	15.6	15.75	15.9	16.05	16.2	16.35	16.5
Rt up (KΩ)	1460.099	192.574	96.642	61.354	43.016	31.781	24.191	18.721	14.590	11.361

AM30EW-xx24S-NZ, xx=24 or 48

Trim down %	1	2	3	4	5	6	7	8	9	10
Vout (VDC)	23.76	23.52	23.28	23.04	22.8	22.56	22.32	22.08	21.84	21.6
Rt down (KΩ)	1286.200	792.123	565.867	436.104	351.954	292.963	249.315	215.714	189.047	167.370
Trim up %	1	2	3	4	5	6	7	8	9	10
Vout (VDC)	24.24	24.48	24.72	24.96	25.2	25.44	25.68	25.92	26.16	26.4
Rt up (KΩ)	816.889	179.914	94.338	60.464	42.307	30.988	23.257	17.640	13.376	10.027

NOTE: 1. Datasheets are updated as needed and as such, specifications are subject to change without notice. Once printed or downloaded, datasheets are no longer controlled by Aimtec; refer to www.aimtec.com for the most current product specifications. **2.** Product labels shown, including safety agency certifications on labels, may vary based on the date manufactured. **3.** Mechanical drawings and specifications are for reference only. **4.** All specifications are measured at an ambient temperature of 25°C, humidity<75%, nominal input voltage and at rated output load unless otherwise specified. **5.** Aimtec may not have conducted destructive testing or chemical analysis on all internal components and chemicals at the time of publishing this document. CAS numbers and other limited information are considered proprietary and may not be available for release. **6.** This product is not designed for use in critical life support systems, equipment used in hazardous environments, nuclear control systems or other such applications which necessitate specific safety and regulatory standards other the ones listed in this datasheet. **7.** Warranty is in accordance with Aimtec's standard Terms of Sale available at www.aimtec.com.