

DRAWING MADE IN AMERICAN PROJECTION

© 1970 BY AMP INCORPORATED. ALL RIGHTS RESERVED. AMP PRODUCTS COVERED BY PATENTS AND/OR PATENTS PENDING.

THIS PRODUCT DESIGNED AND BUILT BY AMP INCORPORATED. NO LICENSE TO USE THAT DESIGN IN MANUFACTURE, OR TO USE ANY ISSUED OR PENDING PATENTS WHICH ARE INVOLVED, IS IMPLIED.

REVISIONS				
ZONE	LTR	DESCRIPTION	DATE	APPROVED
	E	REVISED & REDRAWN	10-14-70	Ken K
	F	REVISED NOTE 1.	10-15-73	J.P.
	G	REVISED PER ECN 4349	5-22-74	M.S.
	H	REV PER ECN S-3960	9/16/87	R.B.

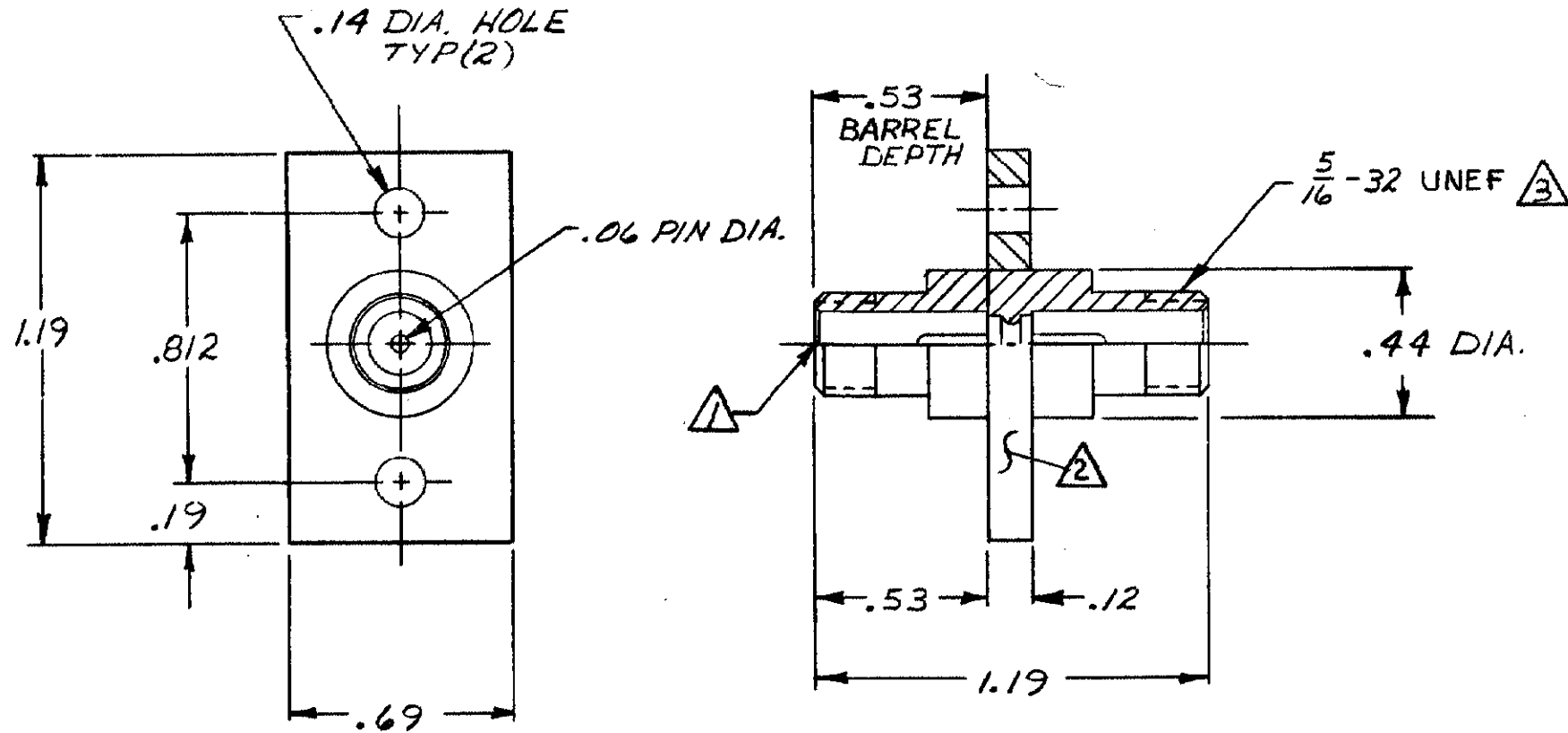

- 1. RECEPTACLE TO MATE WITH AMP LGH-1/2 LEAD ASSEMBLY, AVAILABLE SEPARATELY.
- 2. MARK AMP & AMP PIN (MARKING IN WHITE)
- 3. PER FEDERAL STANDARD H-28 3 WIRE METHOD DIMENSION OVER WIRES TO BE: .307-.318

830174-2	AS SHOWN WITH GOLD PLATED PIN
830174-1	AS SHOWN WITH TIN PLATED PIN

QTY REQD	QTY R_QD	ITEM NO.	DWG SIZE	PART OR IDENTIFYING NO.	NOMENCLATURE OR DESCRIPTION	SYMBOL
-2	-1					

				UNLESS OTHERWISE SPECIFIED: DIMENSIONS ARE IN INCHES TOLERANCES .00 ± .04 ANGLES .000 ± .015		CONTRACT NO. DR J.S. 5-27-65		AMP INCORPORATED CAPITRON DIVISION ELIZABETHTOWN, PENNSYLVANIA	
				MATERIAL: MOLDED GLASS EPOXY		CHK			
				FINISH: BLACK		APPD J.W. GAW 6-18-65		SIZE B	
						APPD		CODE IDENT NO. 89110	
						DSGN APPD		NUMBER 830174	
						OTHER APPD		SCALE 2:1	
								WT	
								SHEET 1/1	

QTY REQD	FINAL ASSY	NEXT ASSY	USED ON	APPLICATION

PRINT DIST 37