

DATA SHEET
SE2613T: 2.4 GHz Wireless LAN/BT Front-End

Applications

- IEEE802.11b DSSS WLAN
- IEEE802.11g,n OFDM WLAN
- Embedded applications with Bluetooth (Mobile)

Features

- Dual Mode IEEE802.11b & IEEE802.11g
- Integrated PA, Harmonic Filter, LNA and BT port
- Integrated Positive Slope Power Detector
- 17.5 dBm @ 4.0 % EVM, 802.11g, 54 Mbps
- Direct connection to battery with 3.6 V nominal supply
- Lead free, Halogen free and RoHS compliant
- Compact package, 3 x 3 x 0.6 mm, MSL 1

Ordering Information

Part No.	Package	Remark
SE2613T	16 pin QFN	Samples
SE2613T-R	16 pin QFN	Tape and Reel
SE2613T-EK1	N/A	Evaluation kit

Product Description

The SE2613T is a complete 802.11 b/g/n WLAN RF front-end module with a Bluetooth port. The device provides all the functionality of the power amplifier, power detector, harmonic filtering, switch, low noise amplifier, and associated matching. The SE2613T provides a complete 2.4 GHz WLAN RF solution from the output of the transceiver to the antenna, and from the antenna to the input of the transceiver, in an ultra compact form factor.

The SE2613T is designed for ease of use, with all the critical matching and harmonic filtering integrated, also offering a simple 50 Ω interface to the antenna.

The SE2613T includes a low noise amplifier to increase the receive sensitivity of embedded solutions to improve range or to overcome the insertion loss of cellular filters often included for mobile applications.

The SE2613T also includes a transmitter power detector with 20 dB of dynamic range and a digital enable control for transmitter power ramp on/off control.

Functional Block Diagram

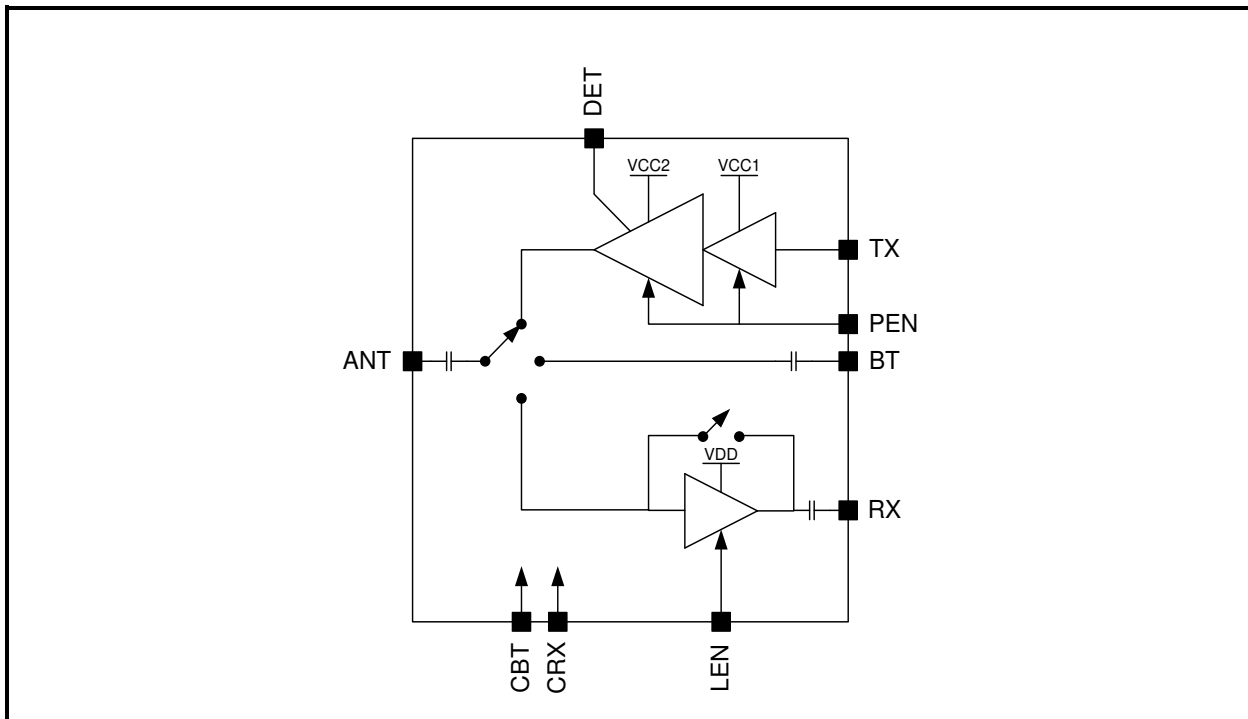

Figure 1: Functional Block Diagram

DATA SHEET
SE2613T: 2.4 GHz Wireless LAN/BT Front-End

Pin Out Diagram

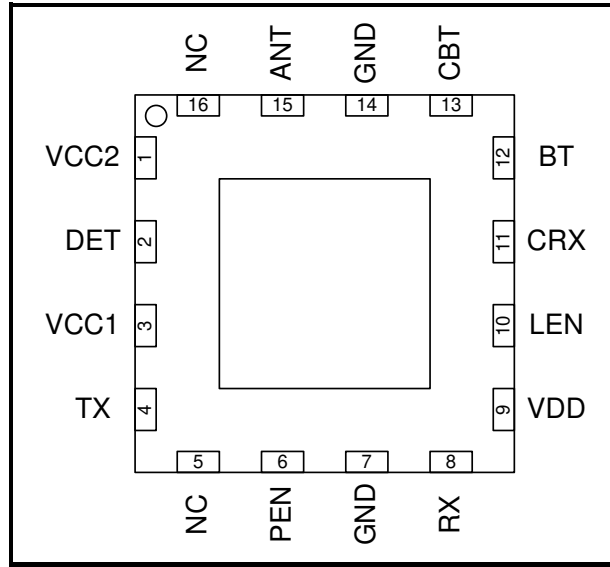

Figure 2: SE2613T Pin out (Top View through Package)

Pin Out Description

Pin No.	Name	Description
1	Vcc2	PA Positive Power supply
2	DET	Power Detector Output
3	Vcc1	PA Positive Power supply
4	TX	Transmit port
5	NC	Not connected
6	PEN	PA enable control input
7	GND	Ground
8	RX	Receive port
9	VDD	LNA and Switch Positive Power supply
10	LEN	LNA enable control input
11	CRX	Receive antenna switch control
12	BT	Bluetooth port
13	CBT	Bluetooth antenna switch control
14	GND	Ground
15	ANT	Antenna port
16	NC	Not connected
Die paddle	GND	Ground

DATA SHEET
SE2613T: 2.4 GHz Wireless LAN/BT Front-End

Absolute Maximum Ratings

These are stress ratings only. Exposure to stresses beyond these maximum ratings (one rating applied at a time) for extended periods may cause permanent damage to, or affect the reliability of the device. Avoid operating the device outside the recommended operating conditions defined below. This device is ESD sensitive. Handling and assembly of this device should be at ESD protected workstations.

Symbol	Definition	Min.	Max.	Unit
VCC	PA Supply Voltage on VCC1, VCC2	-0.3	6.0	V
VDD	LNA and Switch Supply Voltage	-0.3	3.6	V
V _{IN}	DC input on control pins	-0.3	3.6	V
P _{TXIN}	TX Input Power, ANT terminated in 50Ω match	-	5	dBm
T _A	Operating Temperature Range	-40	85	°C
T _{STG}	Storage Temperature Range	-40	150	°C
ESD _{HBM}	JEDEC JESD22-A114 All pins	1000		V

Recommended Operating Conditions

Symbol	Parameter	Min.	Typ.	Max.	Unit
T _A	Ambient temperature	-40	25	85	°C
VCC	PA Supply voltage, relative to GND = 0 V	2.7	3.6	4.8	V
VDD	LNA supply voltage, relative to GND = 0 V	2.7	3.3	3.6	V

DC Electrical Characteristics

Conditions: V_{CC} = 3.6V, V_{DD} = 3.3 V, T_A = 25 °C, as measured on Skyworks Solutions' SE2613T-EK1 evaluation board (de-embedded to device), all unused ports terminated with 50 ohms, unless otherwise noted

Symbol	Parameter	Conditions	Min.	Typ.	Max.	Unit
I _{CC-G}	Total Supply Current	POUT = 17.5 dBm, 54 Mbps OFDM signal, 64QAM	-	140		mA
I _{CC-B}	Total Supply Current	POUT = 20 dBm, 11 Mbps CCK signal, BT = 0.45	-	160		mA
I _{CC}	Quiescent Current	No RF	-	110		mA
I _{CC_OFF}	Total Supply Current	PEN = 0 V, No RF Applied, CBT = PEN = CRX = 0 V	-		10	μA
I _{DD_OFF}	Total Supply Current	PEN = 0 V, No RF Applied, CBT = PEN = CRX = 0 V	-	18	30	μA
I _{CC_LNA}	LNA Supply Current	LEN = 3.3V	-	10	13	mA
I _{CC_LNA_BYP}	LNA bypass supply current	LEN = 0		50		μA

DATA SHEET
SE2613T: 2.4 GHz Wireless LAN/BT Front-End

Control Logic Characteristics

Conditions: $V_{CC} = 3.6V$, $V_{DD} = 3.3V$, $T_A = 25\text{ }^\circ\text{C}$, as measured on Skyworks Solutions' SE2613T-EK1 evaluation board (de-embedded to device), all unused ports terminated with 50 ohms, unless otherwise noted.

Symbol	Parameter	Conditions	Min.	Typ.	Max.	Unit
V_{IH}	Logic High Voltage	-	2.7	-	3.6	V
V_{IL}	Logic Low Voltage	-	0	-	0.4	V
I_{IH}	Input Current Logic High Voltage	-	-	-	100	μA
	PEN				10	
I_{IL}	Input Current Logic Low Voltage	-	-	-	1	μA
	All others					

Control Logic Table

Mode#	Mode Description	CBT	CRX	PEN	LEN
0	All Off	0	0	0	0
1	TX	0	0	1	0
2	RX High gain	0	1	0	1
3	RX Low gain (Bypass)	0	1	0	0
4	BT	1	0	0	0

DATA SHEET
SE2613T: 2.4 GHz Wireless LAN/BT Front-End
AC Electrical Characteristics
802.11g Transmit Characteristics

Conditions: $V_{CC} = 3.6V$, $PEN = VDD = 3.3V$, $CBT = LEN = CRX = 0V$, $T_A = 25^\circ C$, as measured on Skyworks Solutions' SE2613T-EK1 evaluation board (de-embedded to device), all unused ports terminated with 50 ohms, unless otherwise noted.

Symbol	Parameter	Condition	Min.	Typ.	Max.	Unit
F_{IN}	Frequency Range	-	2412	-	2484	MHz
EVM	EVM	$P_{OUT} = 17.5dBm$, 54 Mbps OFDM signal, 64 QAM	-	-	4	%
EVM_{LP}	Low Power EVM	$P_{OUT} = 0-15dBm$, 54 Mbps OFDM	-	-	2.5	%
S_{21}	Small Signal Gain	-	-	26	-	dB
ΔS_{21}	Small Signal Gain Variation Over Band	-	-	-	1.5	dBpp
2f	Harmonics	$P_{OUT} = 20 dBm$, 1 Mbps, 802.11b	-	-	-25	dBm/MHz
3f			-	-	-25	dBm/MHz
t_{dr}, t_{df}	Delay and rise/fall Time	50 % of V_{PEN} edge and 90/10 % of final output power level	-	-	400	nsec
S_{11}	Input Return Loss	TX port	-	-12	-10	dB
STAB	Stability	CW, $P_{in} = -5 dBm$ 0.1 GHz – 20 GHz Load VSWR = 6:1	All non-harmonically related outputs less than -43 dBm/MHz			
RGGD	Ruggedness	CW, $P_{IN} = -5 dBm$ 0.1 GHz – 20 GHz Load VSWR = 10:1	No permanent damage or performance degradation			

Bluetooth Characteristics

Conditions: $V_{CC} = 3.6V$, $CBT = VDD = 3.3V$, $CRX = LEN = PEN = 0V$, $T_A = 25^\circ C$, as measured on Skyworks Solutions' SE2613T-EK1 evaluation board (de-embedded to device), all unused ports terminated with 50 ohms, unless otherwise noted.

Symbol	Parameter	Condition	Min.	Typ.	Max.	Unit
F_{OUT}	Frequency Range	-	2400	-	2500	MHz
BT_{IL}	Insertion Loss	-	-	0.5	0.8	dB
S_{11}	BT Port Return Loss	-	-	-12	-	dB
$ISOL_{SW}$	Switch Isolation	-	24	-	-	dB

DATA SHEET
SE2613T: 2.4 GHz Wireless LAN/BT Front-End

2.4 GHz Receive Characteristics

Conditions: VCC = 3.6 V, LEN = CRX = VDD = 3.3V, PEN = CBT = 0 V, TA = 25 °C, as measured on Skyworks Solutions' SE2613T-EK1 evaluation board (de-embedded to device), all unused ports terminated with 50 ohms, unless otherwise noted.

Symbol	Parameter	Condition	Min.	Typ.	Max.	Unit
F _{OUT}	Frequency Range	-	2400	-	2500	MHz
S ₂₁	Receive Gain, LNA enabled.		11	13	15	dB
ΔS ₂₁	Gain Variation	2400 – 2485 MHz, Over any 20MHz band	-	-	0.5	dB
NF	Noise Figure		-	1.8		dB
IIP3	Third Order Intercept		4	5	-	dBm
S ₁₁	Input Return Loss	-		-10		dB
S ₂₂	Output Return Loss			-10		dB
IP1dB	Input P1dB	CW	-6	-5		dBm
T _{EN}	Enable Time	10% to 90% of RX RF power, from time that LEN is at 50%			400	nsec
S ₂₁ -BYP	Receive Gain, LNA bypassed	LEN = 0 V	-5	-3	-1	dB
S ₁₁ -BYP	Input Return Loss, LNA bypassed	LEN = 0 V		-10		dB
ISOL _{SW}	Switch Isolation		20			dB

DATA SHEET
SE2613T: 2.4 GHz Wireless LAN/BT Front-End

Power Detector Characteristics

Conditions: $V_{CC}=3.6V$, $PEN = VDD = 3.3 V$, $CBT = LEN = CRX = 0V$, $T_A = 25\text{ }^\circ\text{C}$, as measured on Skyworks Solutions' SE2613T-EK1 evaluation board (de-embedded to device), unless otherwise noted.

Symbol	Parameter	Condition	Min.	Typ.	Max.	Unit
F _{OUT}	Frequency Range	-	2400	-	2500	MHz
PDR	Power detect range, CW	Measured at ANT	0	-	22	dBm
PDZ _{LOAD}	Output Impedance	-		2.2		K Ω
PDV _{NoRF}	Output Voltage, P _{OUT} = No RF	Measured in to 1M Ω		0.2		V
PDV _{p17.5}	Output Voltage, P _{OUT} = 17.5 dBm CW	Measured in to 1M Ω		0.8		V
PD _{VVAR}	Detector variation over Voltage	3.2V to 3.9V V _{cc} constant detector voltage (17.5dBm@3.6V V _{cc} nominal)		0.5	1	dBpp
PD _{BW}	Detector bandwidth			1		MHz

DATA SHEET
SE2613T: 2.4 GHz Wireless LAN/BT Front-End

Package Handling Information

Branding Information

The device branding is shown in Figure 3.

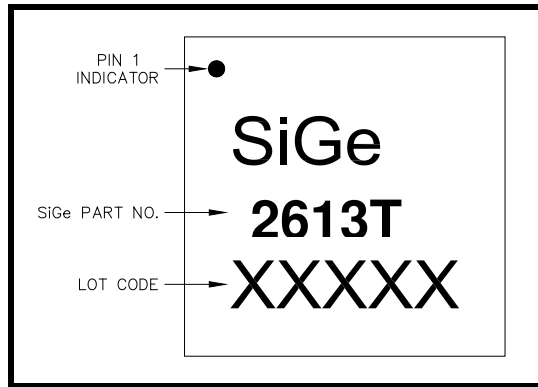

Figure 3: SE2613T Branding and Pin 1 Location

Package Diagram

The package diagram is shown in Figure 4.

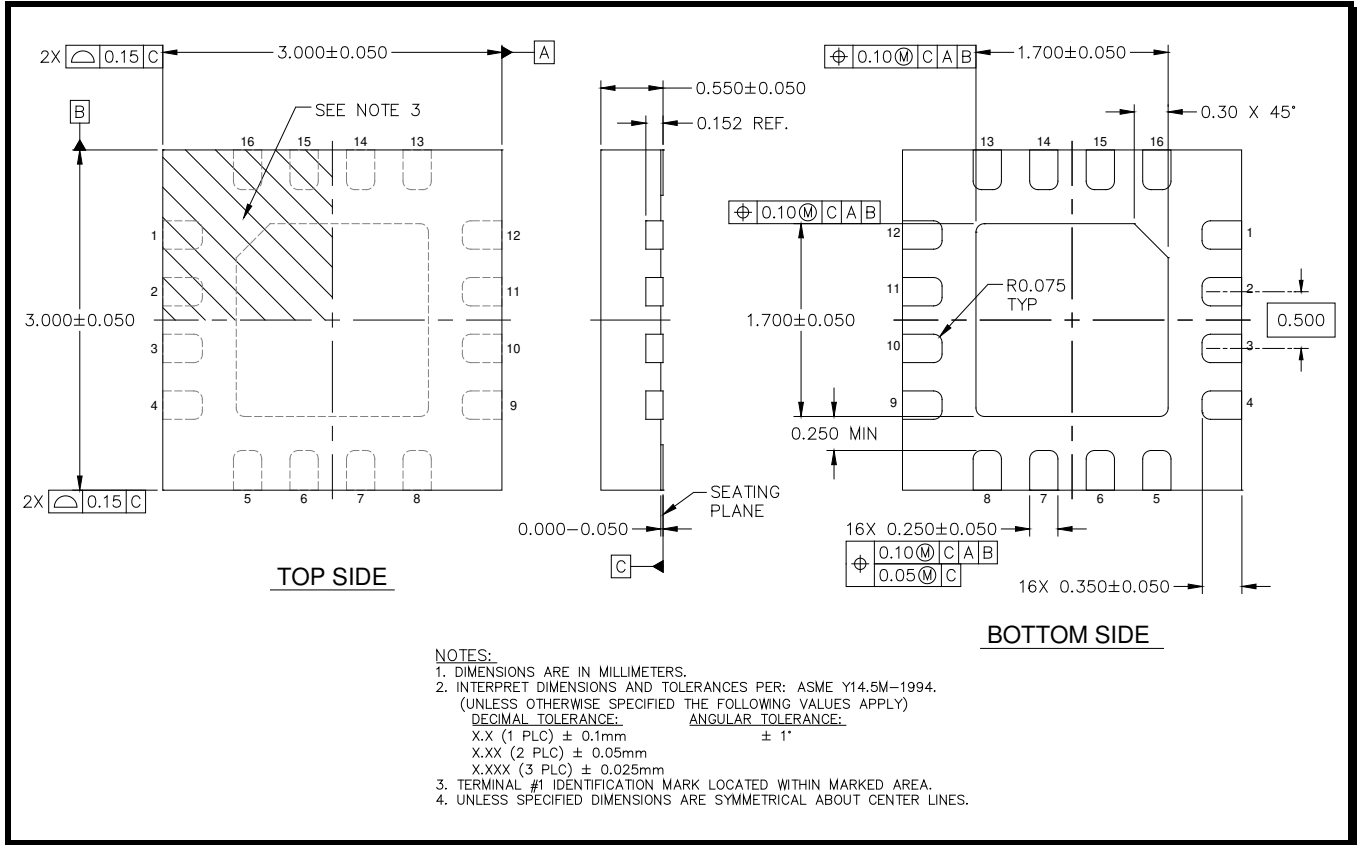
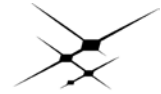

Figure 4: SE2613T Package Diagram



DATA SHEET
SE2613T: 2.4 GHz Wireless LAN/BT Front-End

Recommended PCB Footprint and Solder pattern

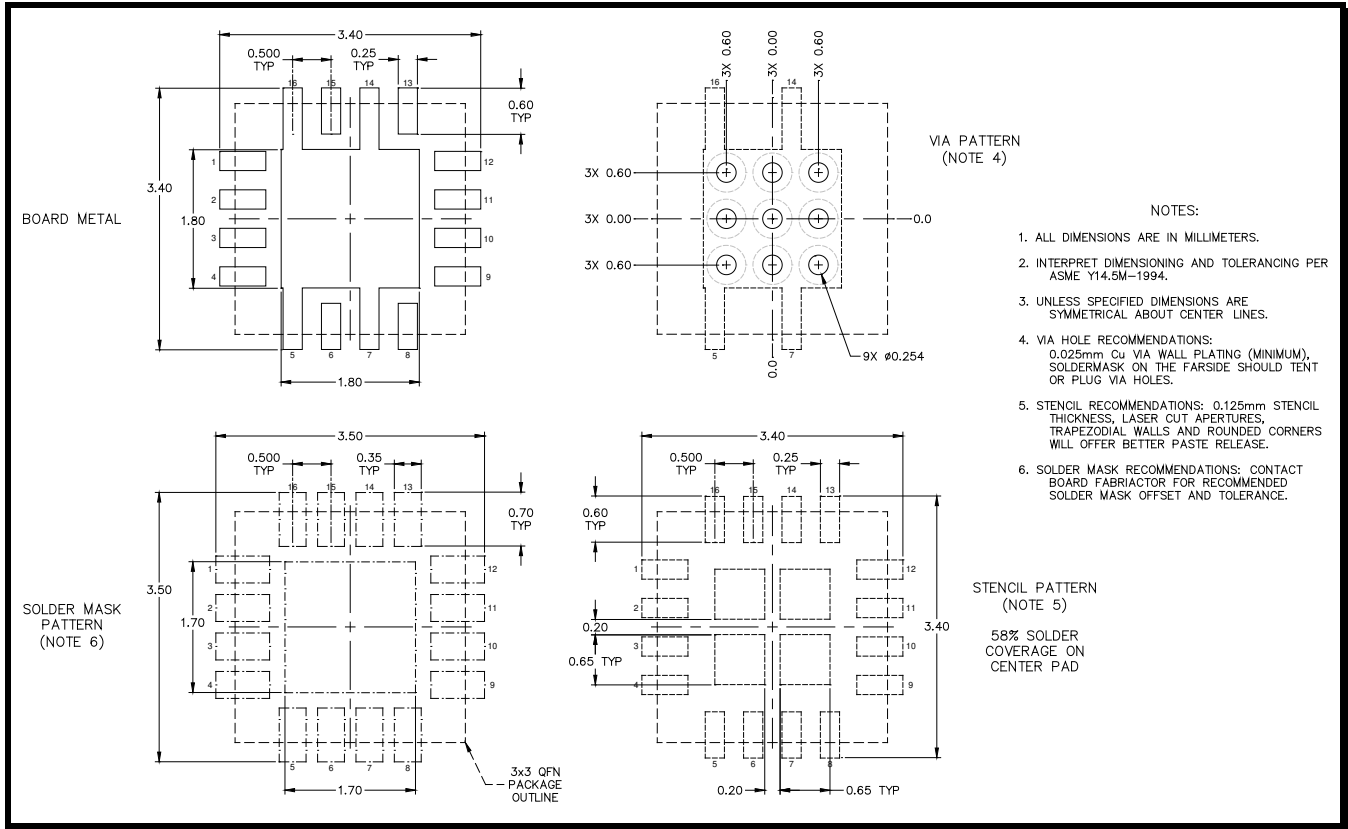

Figure 5: PCB Footprint and Solder pattern

Package Handling Information

Because of its sensitivity to moisture absorption, instructions on the shipping container label must be followed regarding exposure to moisture after the container seal is broken, otherwise, problems related to moisture absorption may occur when the part is subjected to high temperature during solder assembly. The SE2613T is capable of withstanding a Pb free solder reflow. Care must be taken when attaching this product, whether it is done manually or in a production solder reflow environment. If the part is manually attached, precaution should be taken to insure that the device is not subjected to temperatures above its rated peak temperature for an extended period of time. For details on both attachment techniques, precautions, and handling procedures recommended, please refer to:

- “QFN solder reflow and rework information application note”, Document Number QAD-00045
- “Handling, packing, shipping and use of moisture sensitive QFN application note”, Document Number QAD-00044

DATA SHEET
SE2613T: 2.4 GHz Wireless LAN/BT Front-End

Tape and Reel Information

Parameter	Value
Devices Per Reel	3000
Reel Diameter	13 inches
Tape Width	12 millimeters

Figure 6: SE2613T-R Tape and Reel Information.

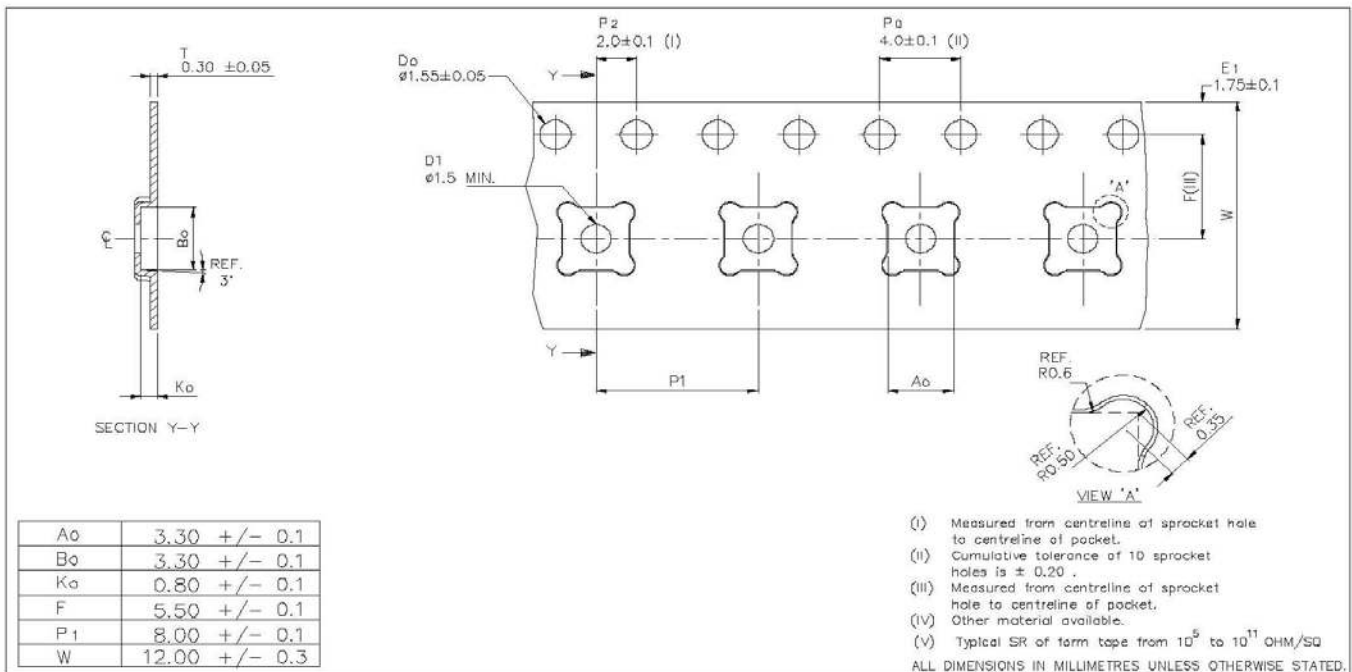



DATA SHEET
SE2613T: 2.4 GHz Wireless LAN/BT Front-End

Document Change History

Revision	Date	Notes
1.0	June-28-2010	Initial Release
1.1	October-01-2010	Updated package, pin out and technical specifications
1.2	October-11-2010	Updated Quiescent current
1.3	November-16-2010	Fixed typos.
1.4	March-28-2011	Updated specifications
1.5	April-11-2012	Updated with Skyworks logo and disclaimer statement

Copyright © 2012 Skyworks Solutions, Inc. All Rights Reserved.

Information in this document is provided in connection with Skyworks Solutions, Inc. ("Skyworks") products or services. These materials, including the information contained herein, are provided by Skyworks as a service to its customers and may be used for informational purposes only by the customer. Skyworks assumes no responsibility for errors or omissions in these materials or the information contained herein. Skyworks may change its documentation, products, services, specifications or product descriptions at any time, without notice. Skyworks makes no commitment to update the materials or information and shall have no responsibility whatsoever for conflicts, incompatibilities, or other difficulties arising from any future changes.

No license, whether express, implied, by estoppel or otherwise, is granted to any intellectual property rights by this document. Skyworks assumes no liability for any materials, products or information provided hereunder, including the sale, distribution, reproduction or use of Skyworks products, information or materials, except as may be provided in Skyworks Terms and Conditions of Sale.

THE MATERIALS, PRODUCTS AND INFORMATION ARE PROVIDED "AS IS" WITHOUT WARRANTY OF ANY KIND, WHETHER EXPRESS, IMPLIED, STATUTORY, OR OTHERWISE, INCLUDING FITNESS FOR A PARTICULAR PURPOSE OR USE, MERCHANTABILITY, PERFORMANCE, QUALITY OR NON-INFRINGEMENT OF ANY INTELLECTUAL PROPERTY RIGHT; ALL SUCH WARRANTIES ARE HEREBY EXPRESSLY DISCLAIMED. SKYWORKS DOES NOT WARRANT THE ACCURACY OR COMPLETENESS OF THE INFORMATION, TEXT, GRAPHICS OR OTHER ITEMS CONTAINED WITHIN THESE MATERIALS. SKYWORKS SHALL NOT BE LIABLE FOR ANY DAMAGES, INCLUDING BUT NOT LIMITED TO ANY SPECIAL, INDIRECT, INCIDENTAL, STATUTORY, OR CONSEQUENTIAL DAMAGES, INCLUDING WITHOUT LIMITATION, LOST REVENUES OR LOST PROFITS THAT MAY RESULT FROM THE USE OF THE MATERIALS OR INFORMATION, WHETHER OR NOT THE RECIPIENT OF MATERIALS HAS BEEN ADVISED OF THE POSSIBILITY OF SUCH DAMAGE.

Skyworks products are not intended for use in medical, lifesaving or life-sustaining applications, or other equipment in which the failure of the Skyworks products could lead to personal injury, death, physical or environmental damage. Skyworks customers using or selling Skyworks products for use in such applications do so at their own risk and agree to fully indemnify Skyworks for any damages resulting from such improper use or sale.

Customers are responsible for their products and applications using Skyworks products, which may deviate from published specifications as a result of design defects, errors, or operation of products outside of published parameters or design specifications. Customers should include design and operating safeguards to minimize these and other risks. Skyworks assumes no liability for applications assistance, customer product design, or damage to any equipment resulting from the use of Skyworks products outside of stated published specifications or parameters.

Skyworks, the Skyworks symbol, and "Breakthrough Simplicity" are trademarks or registered trademarks of Skyworks Solutions, Inc., in the United States and other countries. Third-party brands and names are for identification purposes only, and are the property of their respective owners. Additional information, including relevant terms and conditions, posted at www.skyworksin.com, are incorporated by reference.