

| REVISION RECORD | | | | |
|-----------------|-----|-------------|------|------|
| REV | ECO | DESCRIPTION | DRFT | CHKD |
| | | | | |

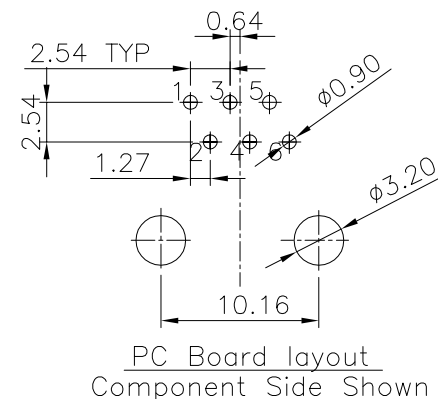
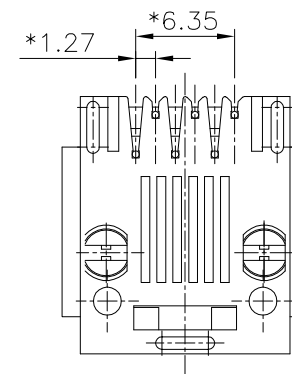
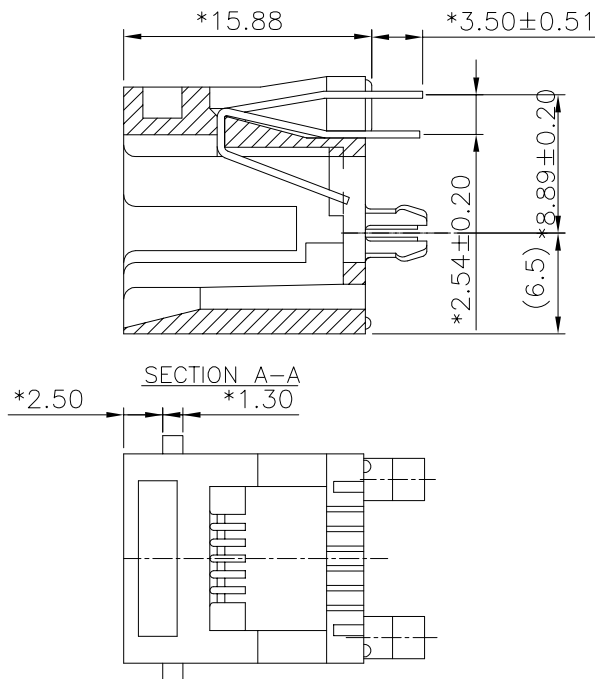
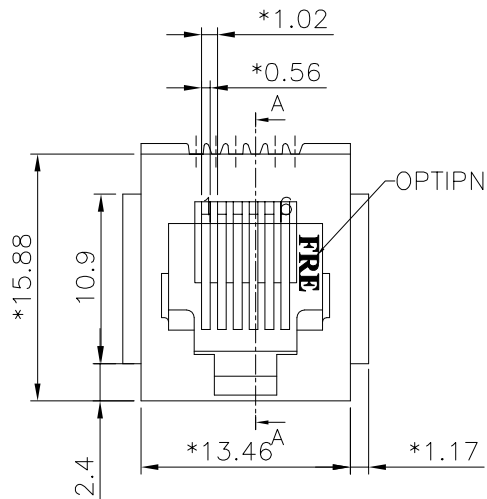

NOTES:

ELECTRICAL:

1. VOLTAGE RATING : 125 VAC RMS MIN.
2. CURRENT RATING : 1.5 AMP MIN.
3. CONTACT RESISTANCE : 30 MILLIOHMS MAX.
4. INSULATION RESISTANCE: 1000 MEGOHMS MIN @ 500 VDC.
5. DIELECTRIC STRENGTH : 1000 VAC RMS 60Hz, 1MIN.

MECHANICAL:

1. HOUSING MATERIAL : GLASS FILLED POLYESTER UL94V-0.
2. CONTACT MATERIAL : PHOSPHOR BRONZE $\phi=0.46\text{mm}$
3. PLATING : GOLD PLATING OVER NICKEL.
4. OPERATING LIFE : 750 CYCLES MIN.
5. PCB RETENTION PRE-SOLDER : 1 LB MIN.
6. PCB RETENTION POST-SOLDER: 10 LBS MIN.

ENVIRONMENTAL:

1. STORAGE : -40°C TO $+85^{\circ}\text{C}$.
2. OPERATION: -40°C TO $+85^{\circ}\text{C}$.
3. WAVE SOLDERING TEMPERATURE: 230°C TO 250°C (3-5SECOND).

MATES WITH MODULAR PLUG CONFORMING TO

FCC PART 68, SUBPART F.

CUL FILE NO. E163191

PART NUMBER: E526X-E000XX-L

- | | |
|---------------|-----------------------------|
| 2- 2 CONTACTS | 1- 3u" 2- 6u" 3-15u" |
| 4- 4 CONTACTS | 4-30u" 5-50u" 6-Pd20u" |
| 6- 6 CONTACTS | 3-W/ PANEL STOP SPLIT FOOT |
| | 4-W/O PANEL STOP SPLIT FOOT |

| MM (INCH) | | DFTO SAMMY | DATE 05/27/05 | FULL RISE ELECTRONIC CO., LTD | |
|----------------------------|--|--------------|----------------|-------------------------------|-----|
| TOLERANCES EXCEPT AS NOTED | | CHKD ANKUE | DATE 2005/5/28 | TITLE | |
| | | MFO | DATE | TOP ENTRY PCB JACK | |
| | | APPV LUSHENG | DATE 2005/5/28 | DRAWING NO. GE523027-LC | |
| | | MATERIAL : | | SIZE | REV |
| ANGLES \pm | | QT'Y : | | A3 | 0 |
| THIRD ANGLE PROJECTION | | FINISH : | | /PART NO. SEE NOTE | |
| | | SCALE : 3:1 | | DO NOT SCALE DRAWING | |
| | | | | SHEET OF | |