

THIS DRAWING IS UNPUBLISHED. RELEASED FOR PUBLICATION 20  
 © COPYRIGHT 20 BY - ALL RIGHTS RESERVED.

REVISIONS				
P	LTR	DESCRIPTION	DATE	APVD
A1		REVISED PER ECR-17-015449	25OCT2017	BDA KR
A2		REVISED PER ECO-20-008510	17JUN2020	WLS DZ
A3		REVISED PER ECN-20-100768	03DEC2020	WLS VS
B		REVISED PER ECN-21-103649	10MAY2021	WLS VS

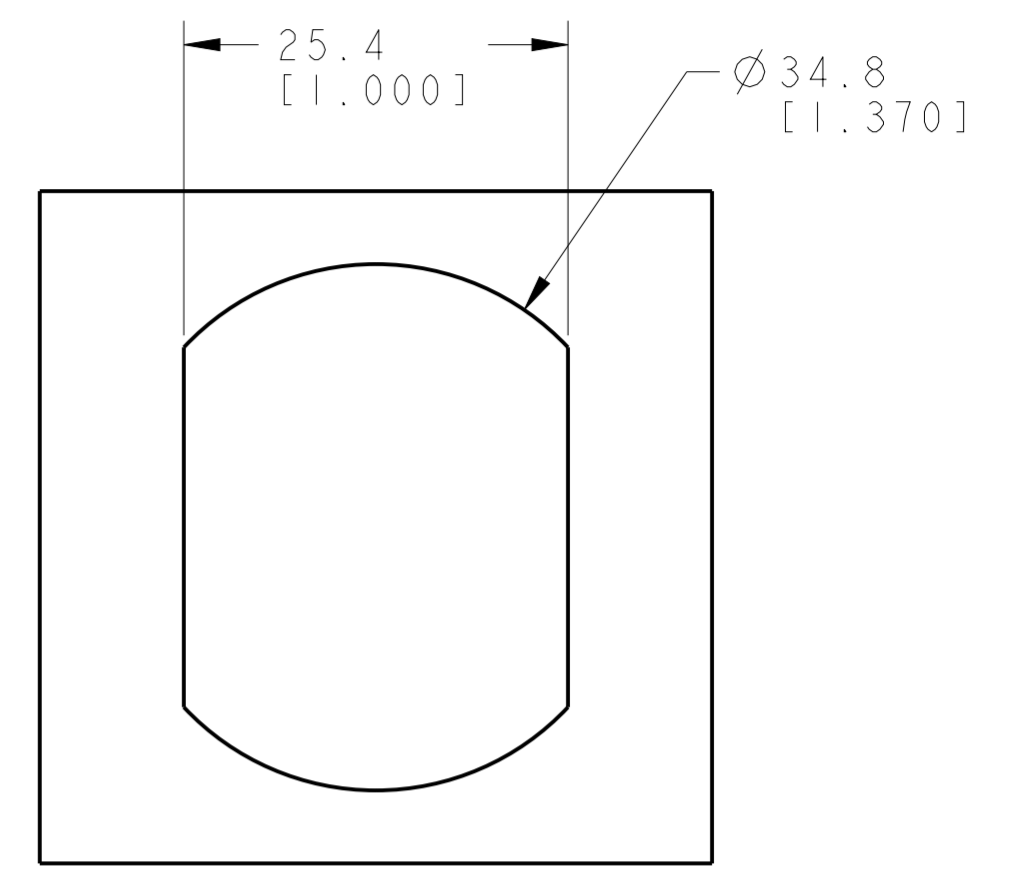

RECOMMENDED  
 PANEL CUT-OUT  
 SCALE 2:1

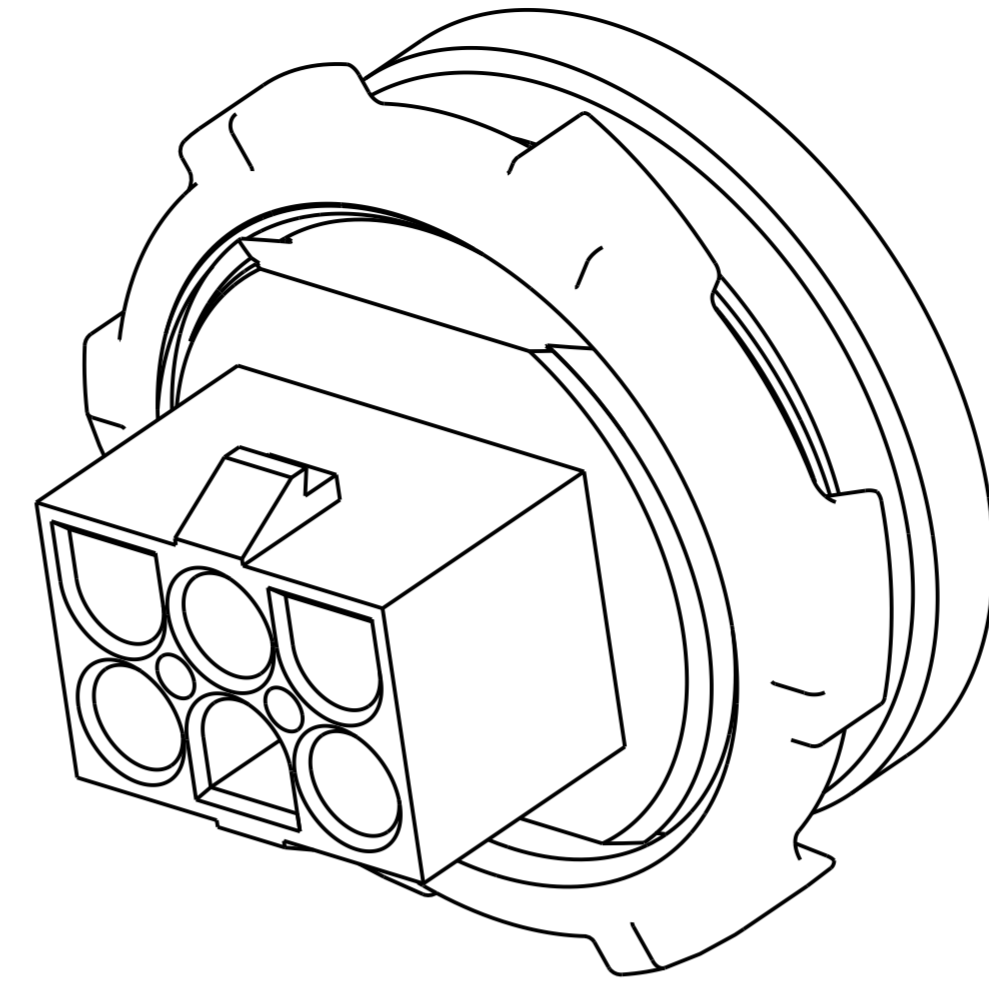
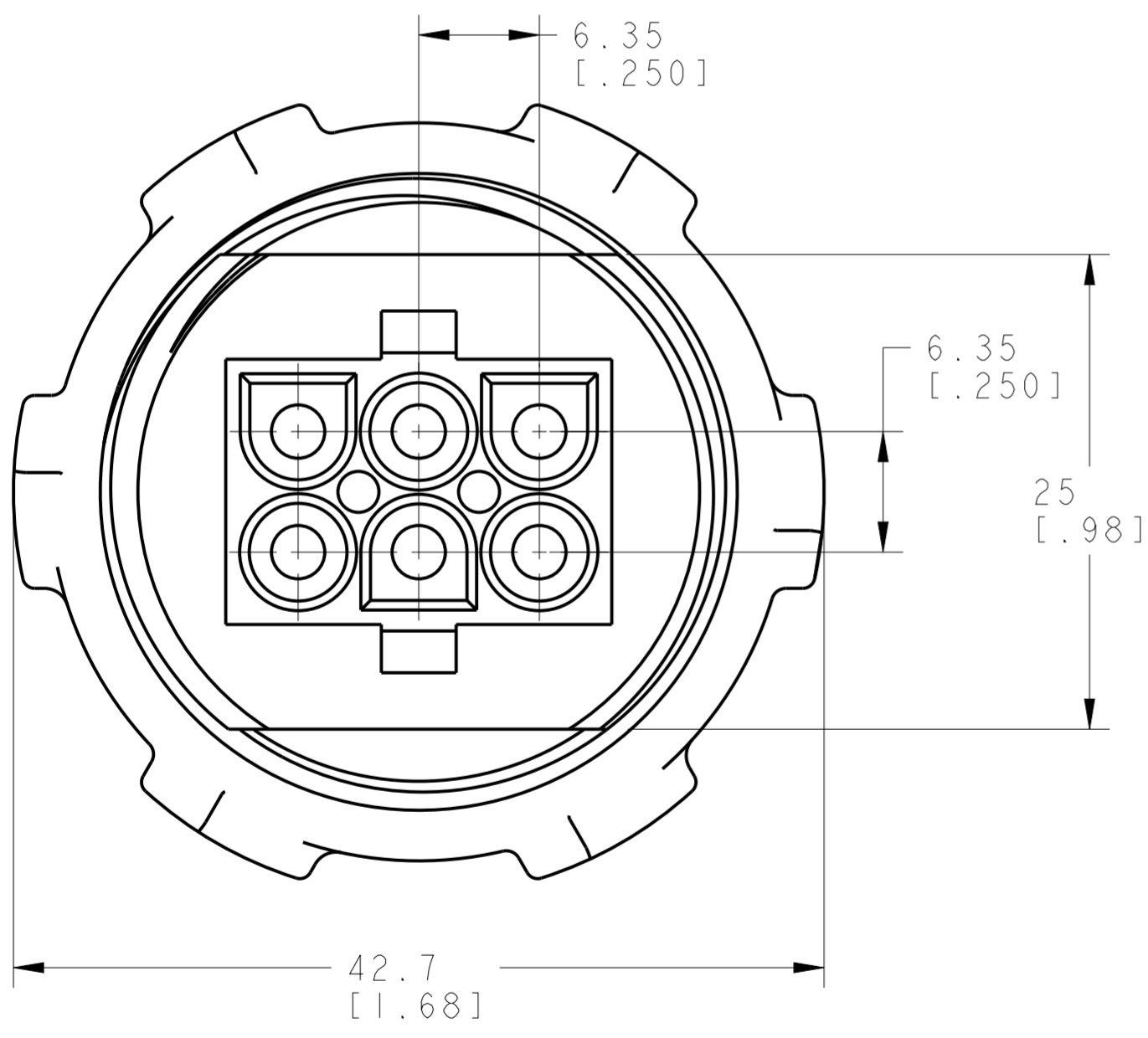
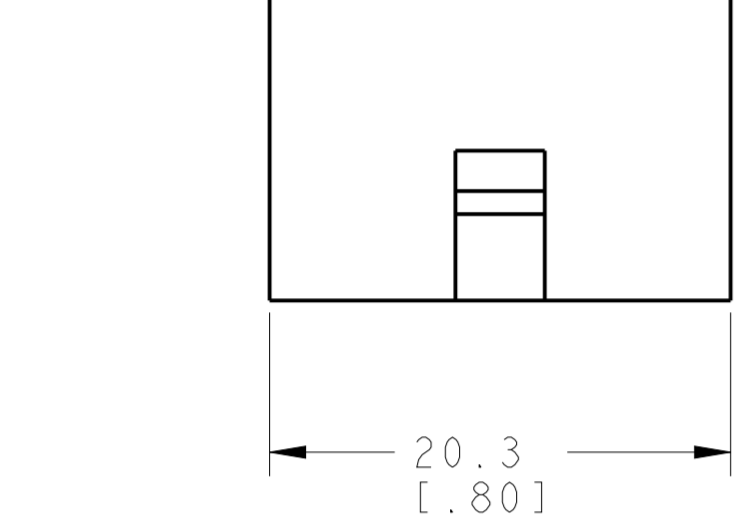
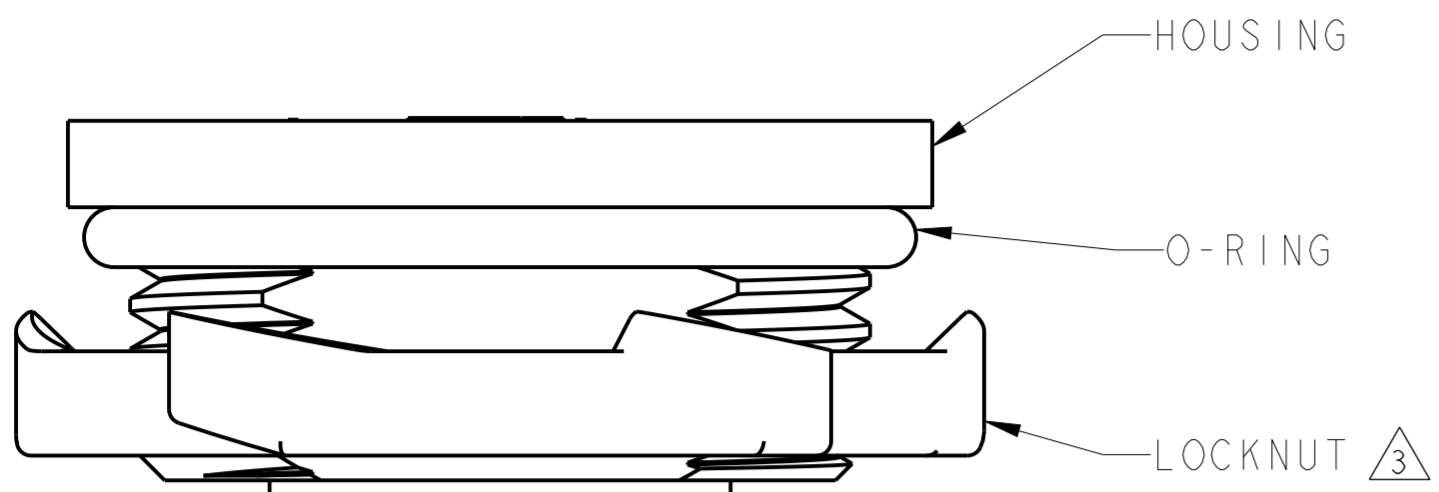
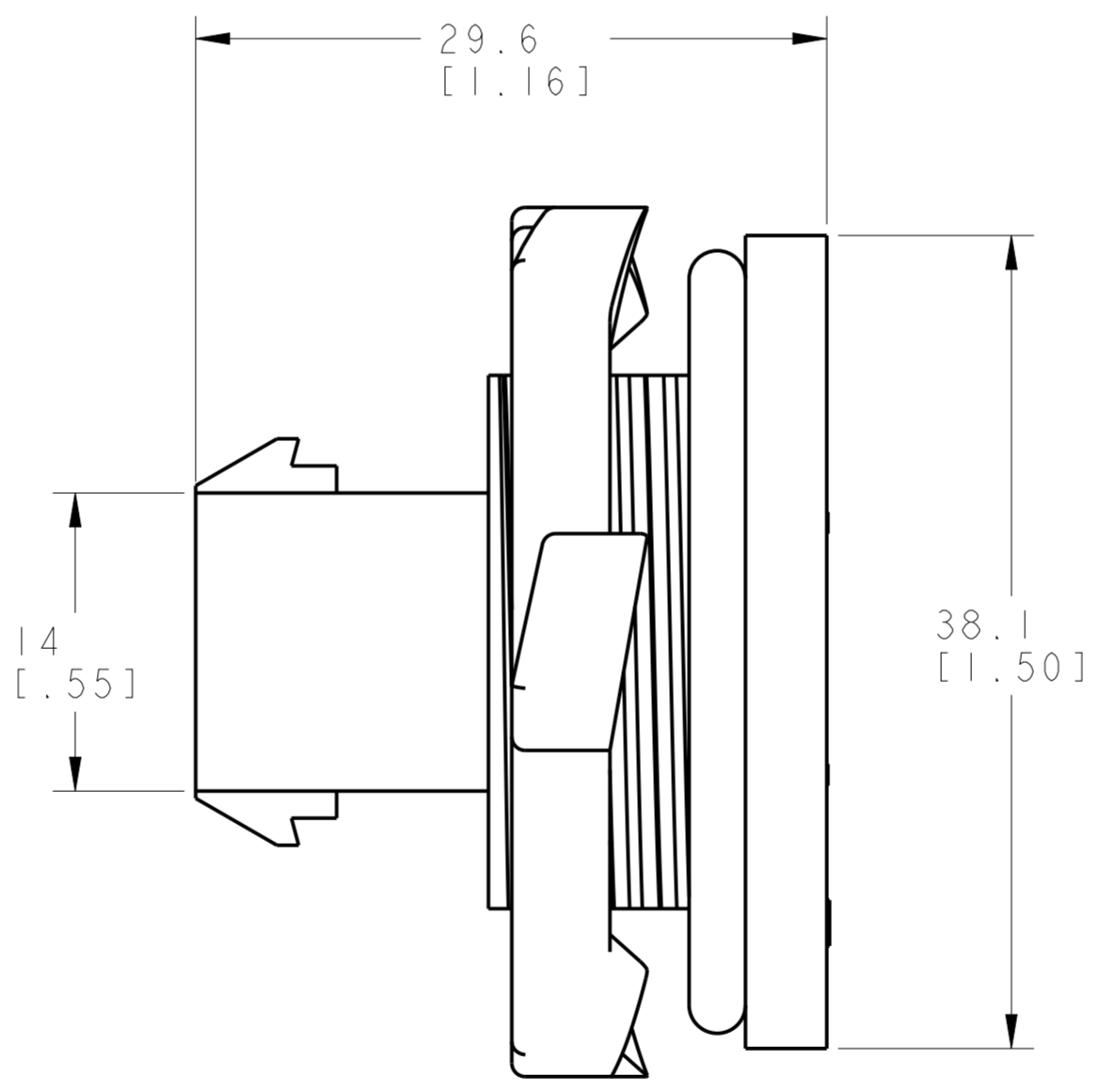

- ① LOCKNUT : METAL  
 HOUSING : NYLON, FLAME RETARDANT, UL94-VO.  
 O-RING : NEOPRENE BLACK (-1) OR  
 SILICONE RUBBER RED (1- -1)
- ② LOCKNUT : PLATED
- ③ LOCKNUT, SIX(6) OR EIGHT(8) SYMETRICAL  
 PLACED GRIP POINTS PERMISSIBLE.
- 4 DIMENSIONS SHOWN REPRESENT PRODUCT  
 IN DRY, AS MOLDED, CONDITION.  
 ADDITIONAL 2% GROWTH DUE TO SUBSEQUENT  
 MOISTURE ABSORPTION MAY OCCUR AND  
 SHOULD BE ACCOUNTED FOR.
- ⑤ ROHS COMPLIANT.

⑤ 1-1604210-1  
 OBSOLETE ~~1604210-1~~  
 PART NO

THIS DRAWING IS A CONTROLLED DOCUMENT.		DWN W J RUDY 14MAR2002	<b>STE</b> TE Connectivity	
DIMENSIONS: mm [INCHES]		CHK JHW 29APR2002		
TOLERANCES UNLESS OTHERWISE SPECIFIED:		APVD JHW 29APR2002	NAME BULKHEAD CONNECTOR ASSEMBLY, 6 CIRCUIT, UNIVERSAL MATE-N-LOK(TM)	
0 PLC ±	±0.5 [0.02]	PRODUCT SPEC	SIZE   CAGE CODE   DRAWING NO	
1 PLC ±0.13 [0.005]		APPLICATION SPEC	A200779   C-1604210	
2 PLC ±		WEIGHT	RESTRICTED TO	
3 PLC ±		CUSTOMER DRAWING	SCALE 3:1 SHEET 1 OF 1 REV B	
4 PLC ±				
ANGLES ±				
FINISH				