

Recommended PCB Layout
Thickness 1.00±0.10mm
Tolerance: ±0.05mm

■ Solder Area □ Component Outline

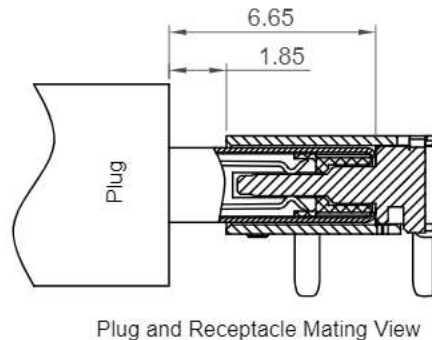

Pin	Signal	Mating Sequence
A5	CC1	Second
A9	V _{bus}	First
A12	GND	First
B5	CC2	Second
B9	V _{bus}	First
B12	GND	First
SHELL	GND	

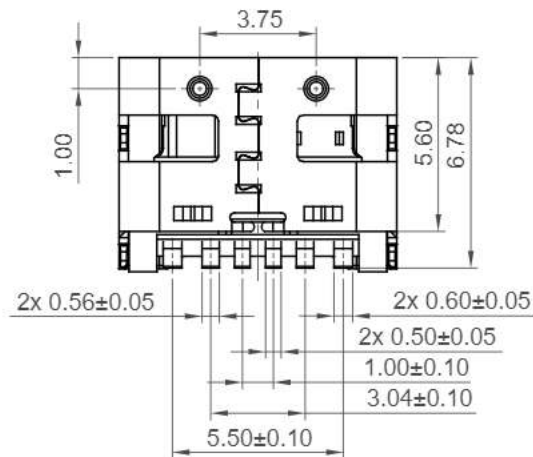
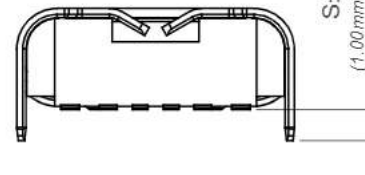
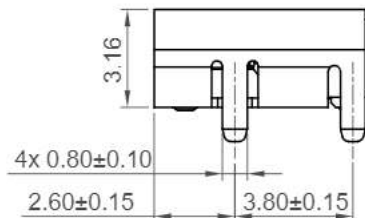
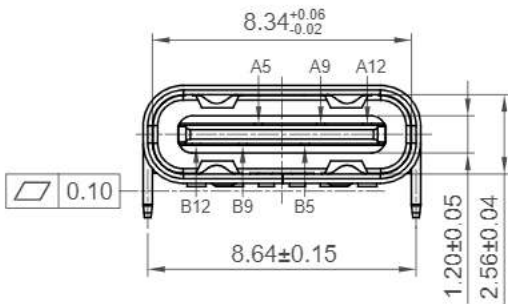
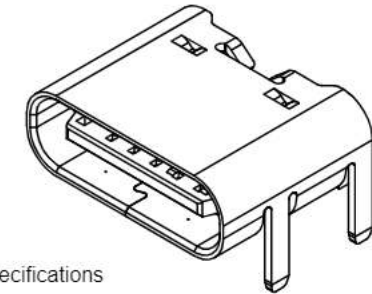

Specifications

Material

Insulator: LCP, UL 94V-0, Black
Contact: Copper Alloy
Shell: Stainless Steel
Middle plate: Stainless Steel

Plating

Contact: Gold Flash All Over
Shell: 50µ" min. Nickel
Middle plate: Clear

Electrical

Current Rating: 3.00A collectively for V_{bus} pins
4.25A collectively for GND pins
1.25A for B5 pin
0.25A for A5 pin

Voltage Rating: 20V DC

Contact Resistance: 40mΩ max initial.
50mΩ max after test

Dielectric Withstanding Voltage: 100V AC
Insulation Resistance 100MΩ min

Mechanical & Environmental

Operating Temperature: -30°C to +85°C

Mating Force: 5 to 20 N

Unmated Force: 6 to 20 N after test

Durability: 20,000 cycles

Ordering Grid

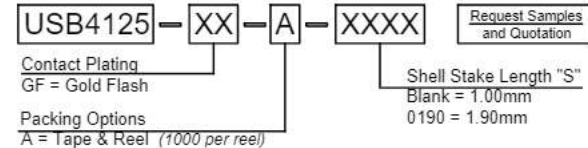

Part Number		Product Description	
USB4125		Type C Receptacle, Horizontal, SMT, For Power Charging Only	
Drawing Date		28th September 2020	
By	CC	Tolerances (Except as Noted)	Units:
Detail	Drawing Release	Length	Metric (mm)
Revision	A3	X.X ± 0.30	
Date	22/11/22	X.XX ± 0.25	
		X.XXX ± 0.10	
		X.XXXX ± 0.10	



Not to Scale Drawn By CC Sheet No. 1/2

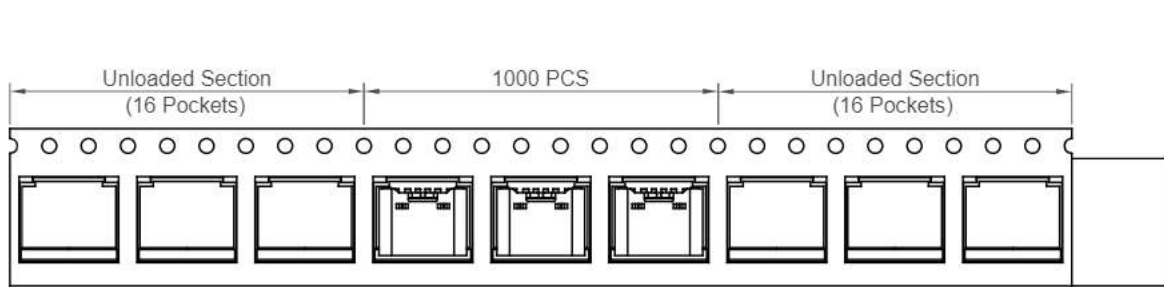

Direction of Unreeling

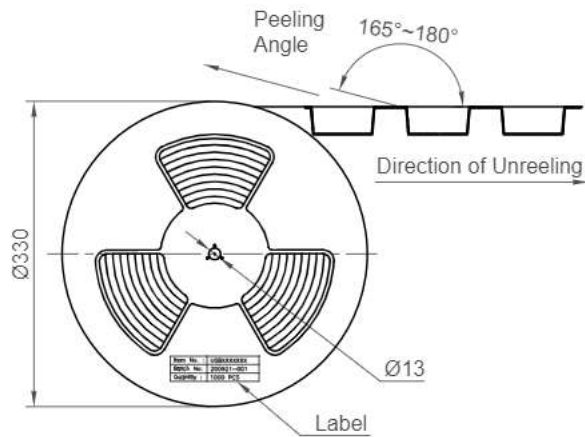

Direction of Unreeling

Direction of Unreeling

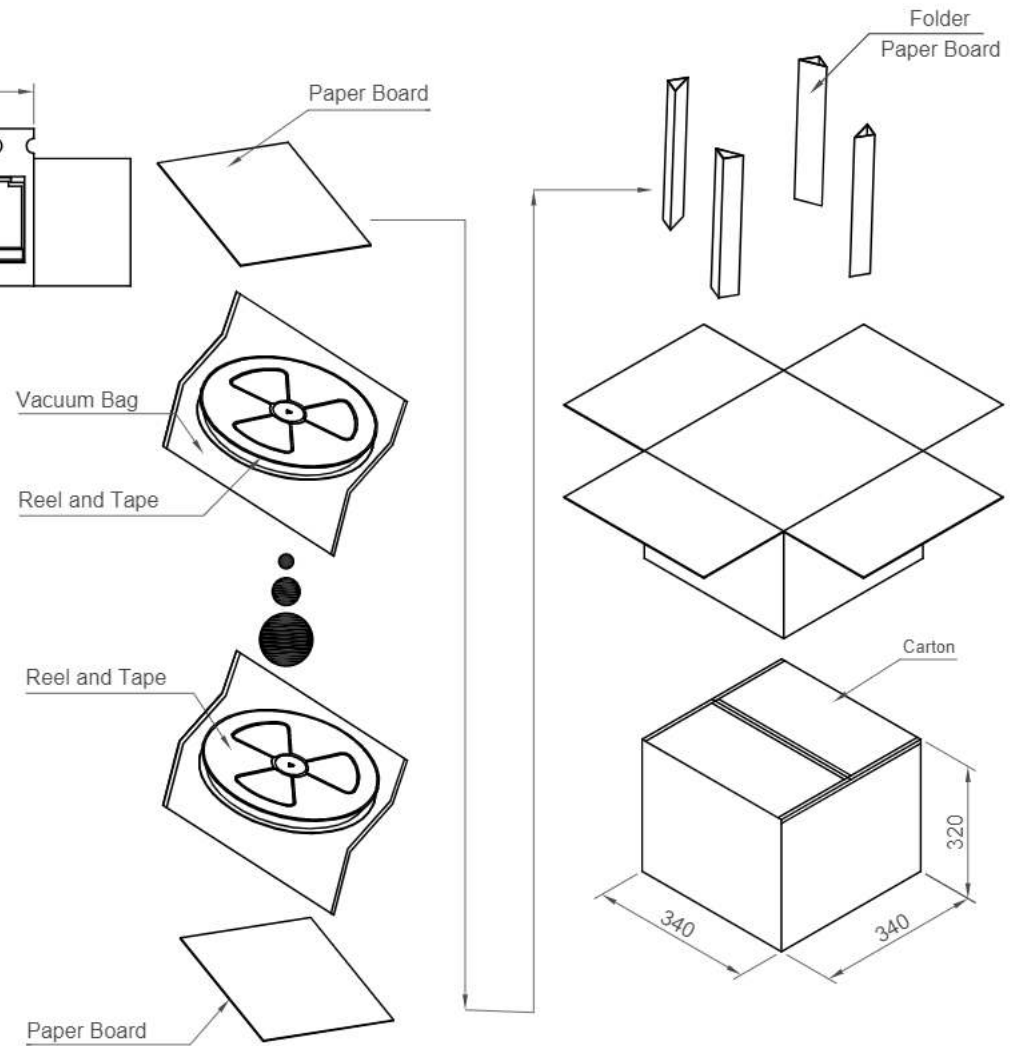
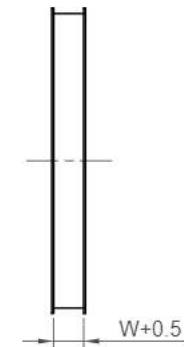
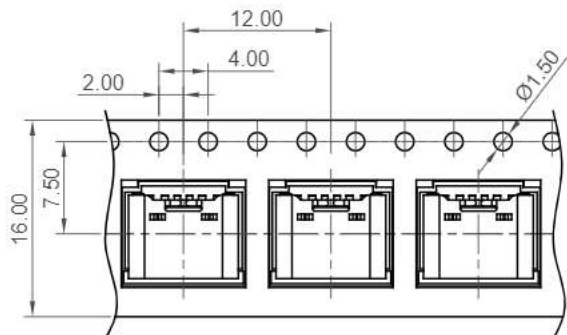

Pcs / Reel	Reels / Carton	Total Quantity
1000	13	13,000 pcs

Part Number USB4125		Product Description Type C Receptacle, Horizontal, SMT, For Power Charging Only	
Drawing Date 28th September 2020			
By CC	Drawing Release	Tolerances (Except as Noted) Length	Angle
Detail	A3	-	-
Revision	22/11/22	Units: Metric (mm)	
Date			
		This drawing is confidential and copyright of Global Connector Technology, Ltd (GCT). This drawing must not be copied or disclosed without written consent. E & OE	



Not to Scale	Drawn By CC	Sheet No. 2/2
--------------	----------------	------------------