

MAXIM

Low-Voltage Reference

ICL8069

General Description

The ICL8069 is a 1.2V temperature-compensated voltage reference. It uses the bandgap principle to achieve excellent stability and low noise at reverse currents down to 50µA. Maxim's ICL8069 also features excellent stability, freedom from oscillation.

Applications

- Analog-to-Digital Converters
- Digital-to-Analog Converters
- Threshold Detectors
- Voltage Regulators
- Portable Instruments

Typical Operating Circuit

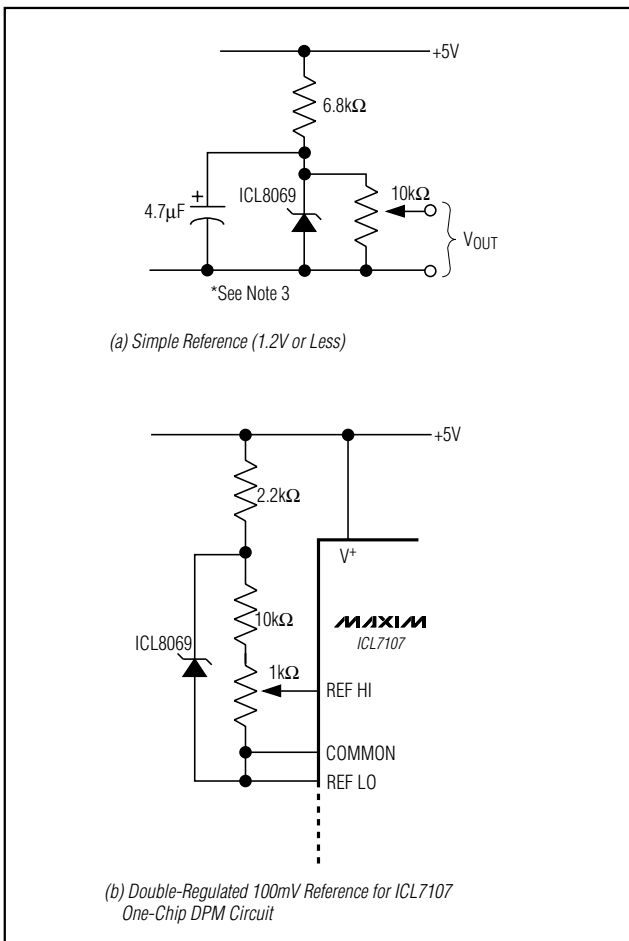

Features

- ◆ Temperature Coefficient Guaranteed to 10ppm/°C max
- ◆ Low Bias Current: 50µA min
- ◆ Low Dynamic Impedance
- ◆ Low Reverse Voltage
- ◆ Low Cost

Ordering Information

| PART | TEMP. RANGE | PIN-PACKAGE | MAX TEMP CO (ppm/°C) |
|--------------|----------------|-------------|----------------------|
| ICL8069BCSA | 0°C to +70°C | 8 SO | 25 |
| ICL8069CCSA | 0°C to +70°C | 8 SO | 50 |
| ICL8069DCSA | 0°C to +70°C | 8 SO | 100 |
| ICL8069DESA | -40°C to +85°C | 8 SO | 100 |
| ICL8069CCZQ2 | 0°C to +70°C | TO-92 | 50 |
| ICL8069DCZQ2 | 0°C to +70°C | TO-92 | 100 |

Ordering Information continued at end of data sheet.

Pin Configurations

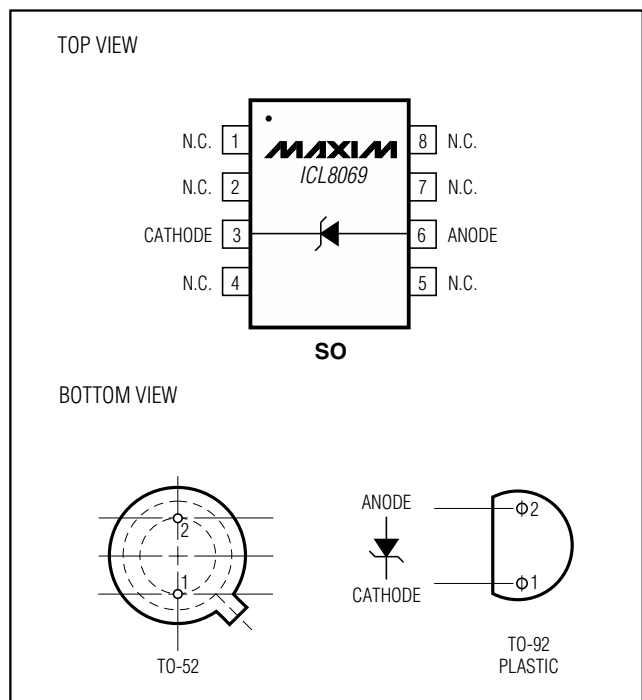

Low-Voltage Reference

ABSOLUTE MAXIMUM RATINGS

| | |
|--|---|
| Reverse Voltage(Note 1) | Operating Temperature Ranges |
| Forward Current 10mA | ICL8069C0°C to +70°C |
| Reverse Current 10mA | ICL8069E-40°C to +85°C |
| Power Dissipation.....Limited by Max Forward/Reverse Current | ICL8069M-55°C to +125°C |
| Storage Temperature Range-65°C to +150°C | Lead Temperature (soldering, 10sec)+300°C |

Note 1: In normal use, the reverse voltage cannot exceed the reference voltage. However, when plugging units into a powered-up test fixture, an instantaneous voltage equal to the compliance of the test circuit will be seen. This should not exceed 20V.

Stresses beyond those listed under "Absolute Maximum Ratings" may cause permanent damage to the device. These are stress ratings only, and functional operation of the device at these or any other conditions beyond those indicated in the operational sections of the specifications is not implied. Exposure to absolute maximum rating conditions for extended periods may affect device reliability.

ELECTRICAL CHARACTERISTICS

(T_A = +25°C, unless otherwise noted.) (Note 2)

| PARAMETER | CONDITIONS | MIN | TYP | MAX | UNITS |
|--|---|----------|------|------|--------|
| Output Voltage | I _R = 500μA | 1.20 | 1.23 | 1.25 | V |
| Output Voltage Temperature Coefficient | I _R = 500μA, T _A = operating temperature range (Note 3) | ICL8069A | | 10 | ppm/°C |
| | | ICL8069B | | 25 | |
| | | ICL8069C | | 50 | |
| | | ICL8069D | | 100 | |
| Output Voltage Change | 50μA ≤ I _R ≤ 5mA | | 15 | 20 | mV |
| Reverse Dynamic Impedance | I _R = 50μA, I _R = 500μA | | 1 | 2 | Ω |
| | | | 0.6 | 2 | |
| Forward Voltage Drop | I _F = 500μA | | 0.7 | 1 | V |
| RMS Noise Voltage | 10Hz ≤ f ≤ 10kHz, I _R = 500μA | | 5 | | μV |
| Reverse Current Range | | 0.050 | | 5 | mA |

Note 2: If circuit strays in excess of 200pF are anticipated, a 4.7μF shunt capacitor will ensure stability under all operating conditions.

Note 3: For military devices, measurements are made at +25°C, -55°C, and +125°C, while for commercial devices measurements are made at +25°C, 0°C, and +70°C. The units are then classified as a function of the worst-case TC. Sample tested to 0.1% AQL.

Low-Voltage Reference

Typical Operating Characteristics

($T_A = +25^\circ\text{C}$, unless otherwise noted.)

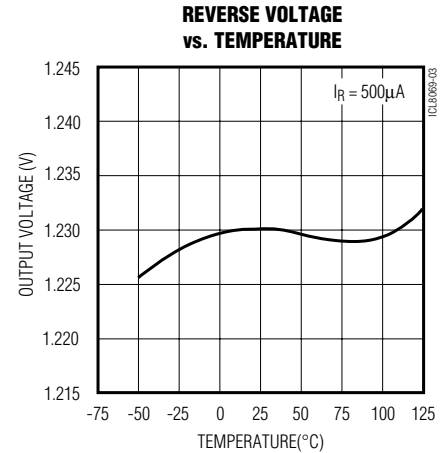
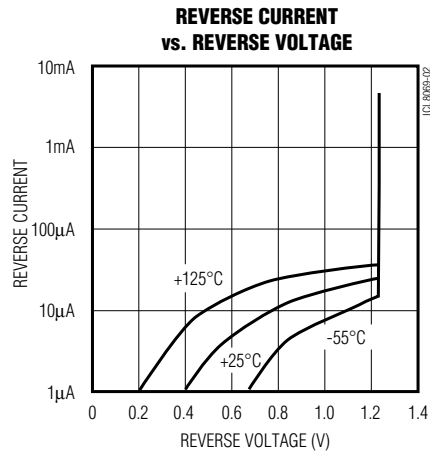
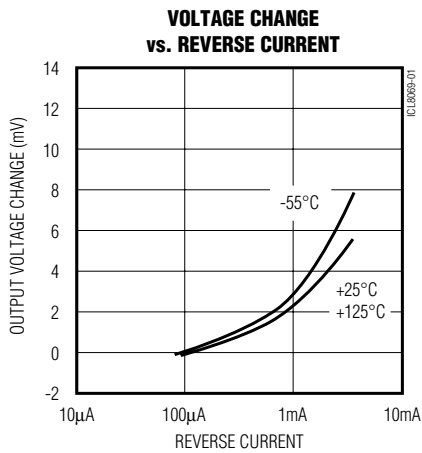

ICL8069

Ordering Information (continued)

| PART | TEMP RANGE | PIN-PACKAGE | MAX TEMPCO (ppm/°C) |
|---------------|-----------------|-------------|---------------------|
| ICL8069ACSA* | 0°C to +70°C | 8 SO | 10 |
| ICL8069BCZQ2* | 0°C to +70°C | TO-92 | 25 |
| ICL8069ACSQ2* | 0°C to +70°C | TO-52 | 10 |
| ICL8069BCSQ2* | 0°C to +70°C | TO-52 | 25 |
| ICL8069CCSQ2* | 0°C to +70°C | TO-52 | 50 |
| ICL8069DCSQ2* | 0°C to +70°C | TO-52 | 100 |
| ICL8069CMSQ2* | -55°C to +125°C | TO-52 | 50 |
| ICL8069DMSQ2* | -55°C to +125°C | TO-52 | 100 |
| ICL8069DC/D* | 0°C to +70°C | Dice** | — |

**Dice are specified at $T_A = +25^\circ\text{C}$.

*Contact factory for availability.

Low-Voltage Reference

Package Information

| SYMBOL | INCHES | | MILLIMETERS | |
|--------|-----------|------|-------------|------|
| | MIN | MAX | MIN | MAX |
| A | .115 | .150 | 2.92 | 3.81 |
| f b | --- | .021 | --- | .533 |
| f b2 | .016 | .019 | .406 | .483 |
| f D | .209 | .230 | 5.31 | 5.84 |
| f D1 | .178 | .195 | 4.52 | 4.95 |
| e | .100 T.P. | | 2.54 T.P. | |
| e1 | .050 T.P. | | 1.27 T.P. | |
| F | --- | .030 | --- | .762 |
| J | .036 | .046 | .914 | 1.17 |
| k | .028 | .048 | .711 | 1.22 |
| L | .500 | --- | 12.70 | --- |
| L1 | --- | .050 | --- | 1.27 |
| L2 | .250 | --- | 6.35 | --- |
| Q | 45° T.P. | | 45° T.P. | |

NOTES: DIMENSIONS ARE COMPLIANT TO JEDEC, TO-52.

| | | | |
|---------------------------------------|-------|--------------------------|------|
| TOLERANCES UNLESS OTHERWISE SPECIFIED | | MAXIM | |
| FRACTIONS DEC ANGLES | | PROPRIETARY INFORMATION | |
| + N/A +.001 + N/A | | TITLE: | |
| DRAWN BY: | DATE: | CASE OUTLINE TO-52, 2 LD | |
| APPROVED BY: | DATE: | DOCUMENT CONTROL NO. | REV. |
| | | 21-0020 | A |

| INCHES | | MILLIMETERS | |
|--------|-------|-------------|------|
| MIN | MAX | MIN | MAX |
| A | 0.053 | 0.069 | 1.35 |
| A1 | 0.004 | 0.010 | 0.25 |
| B | 0.014 | 0.019 | 0.35 |
| C | 0.007 | 0.010 | 0.19 |
| e | 0.050 | | 1.27 |
| E | 0.150 | 0.157 | 3.80 |
| H | 0.228 | 0.244 | 5.80 |
| h | 0.010 | 0.020 | 0.25 |
| L | 0.016 | 0.050 | 0.40 |

| INCHES | | MILLIMETERS | | N | MS012 |
|--------|-------|-------------|------|-------|-------|
| MIN | MAX | MIN | MAX | | |
| D | 0.189 | 0.197 | 4.80 | 5.00 | 8 |
| D | 0.337 | 0.344 | 8.55 | 8.75 | 14 |
| D | 0.386 | 0.394 | 9.80 | 10.00 | 16 |

NOTES:
 1. DAE DO NOT INCLUDE MOLD FLASH
 2. MOLD FLASH OR PROTRUSIONS NOT TO EXCEED .15mm (.006")
 3. LEADS TO BE COPLANAR WITHIN .102mm (.004")
 4. CONTROLLING DIMENSION: MILLIMETER
 5. MEETS JEDEC MS012-XX AS SHOWN IN ABOVE TABLE
 6. N = NUMBER OF PINS

| | | | |
|-------------------------|-----------------------------------|------------------------------|-----------|
| MAXIM | PACKAGE FAMILY OUTLINE: SOIC .150 | 1/1 | 21-0041 A |
| PROPRIETARY INFORMATION | | DOCUMENT CONTROL NUMBER REV. | |

Maxim cannot assume responsibility for use of any circuitry other than circuitry entirely embodied in a Maxim product. No circuit patent licenses are implied. Maxim reserves the right to change the circuitry and specifications without notice at any time.

4 Maxim Integrated Products, 120 San Gabriel Drive, Sunnyvale, CA 94086 408-737-7600