

AERO[®] TRANSCEIVER FOR GSM AND GPRS WIRELESS COMMUNICATIONS

Features

- Low-IF receiver:
 - Dual or triple-band LNA
 - Image-reject down-converter
 - High-performance A/D converters
- Universal baseband interface:
 - Digital IF to baseband converter, channel-select filter and gain control
 - Analog or digital I/Q interface
- Offset-PLL transmitter:
 - High precision I/Q up-converter
 - Integrated TX VCO and loop filter
- Dual RF synthesizer:
 - Integrated RF and IF VCOs, loop filters, varactors, and resonators
- Quad-band support:
 - GSM 850 Class 4, small MS
 - E-GSM 900 Class 4, small MS
 - DCS 1800 Class 1
 - PCS 1900 Class 1
- GPRS Class 12 compliant
- CMOS process technology
- Low profile packages:
 - Si4200: 5 x 5 mm QFN32
 - Si4201: 4 x 4 mm QFN20
 - Si4133T: 5 x 5 mm QFN28
- 3-wire serial interface
- 2.7 V to 3.0 V operation

Applications

- Multi-band GSM/GPRS digital cellular handsets
- GSM/GPRS wireless data modems

Description

The Aero[®] transceiver is a complete RF front end for multi-band GSM and GPRS wireless communications. The transmit section interfaces between the baseband processor and the power amplifier. The receive section interfaces between the RF band-select SAW filters and the baseband processor. No external IF SAW filter or VCO modules are required as all functions are completely implemented on-chip, resulting in a dramatic reduction of board area and component count.

Functional Block Diagram

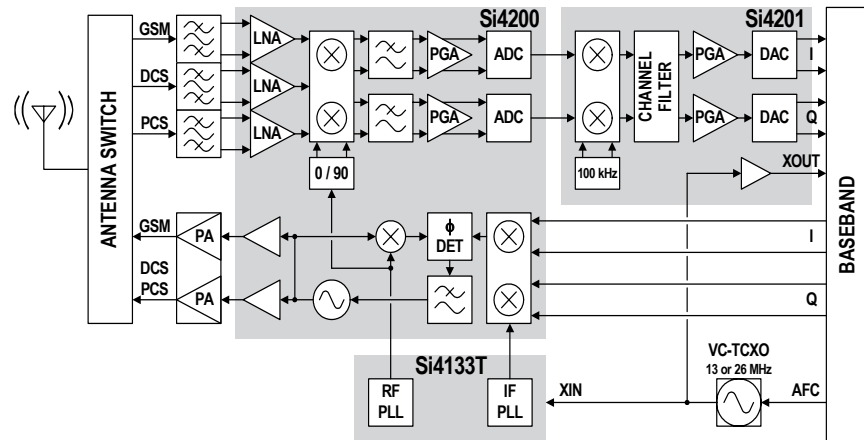

Pin Assignments (Top View)

Si4200-G-GM (Si4200DB-BM see page 41)

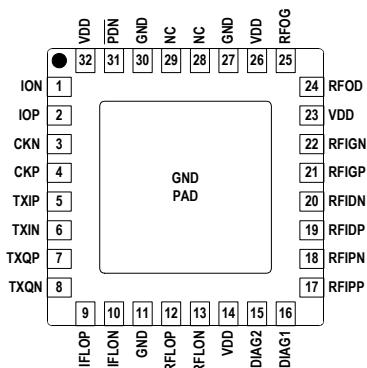

Si4201-BM

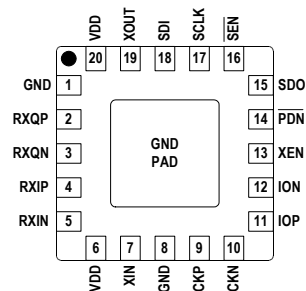

Si4133T-BM

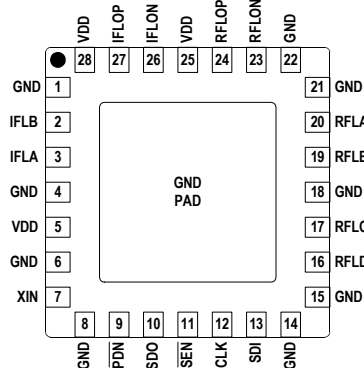

**Ordering Information:
See page 44.**

Patents pending

TABLE OF CONTENTS

| <u>Section</u> | <u>Page</u> |
|---|--------------------|
| 1. Electrical Specifications | 4 |
| 2. Typical Application Schematic | 17 |
| 3. Bill of Materials | 18 |
| 4. Functional Description | 19 |
| 4.1. Receive Section | 20 |
| 4.2. Transmit Section | 21 |
| 4.3. Frequency Synthesizer | 22 |
| 4.4. VCO Inductor Design | 23 |
| 4.5. Serial Interface | 24 |
| 4.6. XOUT Buffer | 24 |
| 5. Control Registers | 25 |
| 6. Pin Descriptions: Si4200-G-GM | 40 |
| 7. Pin Descriptions: Si4200DB-BM | 41 |
| 8. Pin Descriptions: Si4201-BM | 42 |
| 9. Pin Descriptions: Si4133T-BM | 43 |
| 10. Ordering Guide | 44 |
| 11. Package Outline: Si4200-G-GM and Si4200DB-BM | 45 |
| 12. Package Outline: Si4201-BM | 46 |
| 13. Package Outline: Si4133T-BM | 47 |
| Document Change List | 48 |
| Contact Information | 50 |

1. Electrical Specifications

Table 1. Recommended Operating Conditions^{1,2}

| Parameter | Symbol | Test Condition | Min | Typ | Max | Unit |
|-------------------------------|--------------|----------------|------|------|-----|------|
| Ambient Temperature | T_A | | -20 | 25 | 85 | °C |
| DC Supply Voltage | V_{DD} | | 2.7 | 2.85 | 3.0 | V |
| DC Supply Voltages Difference | V_{Δ} | | -0.3 | — | 0.3 | V |

Notes:

- All minimum and maximum specifications are guaranteed and apply across the recommended operating conditions. Typical values apply at 2.85 V and an operating temperature of 25 °C unless otherwise stated. Parameters are tested in production unless otherwise stated.
- DC supply voltage difference specification applies to power supply pins per IC.

Table 2. Absolute Maximum Ratings^{1,2}

| Parameter | Symbol | Value | Unit |
|-----------------------------|-----------|----------------------------|------|
| DC Supply Voltage | V_{DD} | -0.5 to 3.3 | V |
| Input Current ³ | I_{IN} | ±10 | mA |
| Input Voltage ³ | V_{IN} | -0.3 to ($V_{DD} + 0.3$) | V |
| Operating Temperature | T_{OP} | -40 to 95 | °C |
| Storage Temperature | T_{STG} | -55 to 150 | °C |
| RF Input Level ⁴ | | 10 | dBm |

Notes:

- Permanent device damage may occur if the above Absolute Maximum Ratings are exceeded. Functional operation should be restricted to the conditions as specified in the operational sections of this data sheet. Exposure to absolute maximum rating conditions for extended periods may affect device reliability.
- The Si4200 and Si4133T devices are high-performance RF integrated circuits with an ESD rating of < 2 kV. Handling and assembly of these devices should only be done at ESD-protected workstations.**
- For signals SCLK, SDI, SEN, PDN, XEN, and XIN.
- At SAW filter output for all bands.

Table 3. DC Characteristics $(V_{DD} = 2.7$ to 3.0 V, $T_A = -20$ to 85 °C)

| Parameter | Symbol | Test Condition | Min | Typ | Max | Unit |
|--|-------------|---|--------------|-----|--------------|---------|
| Si4200 Supply Current | I_{RX0} | Receive mode | — | 55 | 80 | mA |
| | I_{TX0} | Transmit mode | — | 60 | 80 | mA |
| | I_{PDN0} | $\overline{PDN} = 0$ | — | 1 | 50 | μ A |
| Si4201 Supply Current ¹ | I_{RX1} | Receive mode | — | 9 | 12 | mA |
| | I_{PDN1} | $\overline{PDN} = 0$, XEN = 0, XBUF = 0, XPD1 = 1 | — | 1 | 50 | μ A |
| | I_{XOUT1} | $\overline{PDN} = 0$, XEN = 1 | — | 1 | 2 | mA |
| Si4133T Supply Current ² | I_{RX3} | Receive mode | — | 16 | 19 | mA |
| | I_{TX3} | Transmit mode | — | 22 | 27 | mA |
| | I_{PDN3} | $\overline{PDN} = 0$ | — | 1 | 50 | μ A |
| Total Chipset Supply Current | I_{RX} | Receive mode | — | 80 | — | mA |
| | I_{TX} | Transmit mode | — | 82 | — | mA |
| High Level Input Voltage ³ | V_{IH} | | $0.7 V_{DD}$ | — | — | V |
| Low Level Input Voltage ³ | V_{IL} | | — | — | $0.3 V_{DD}$ | V |
| High Level Input Current ³ | I_{IH} | $V_{IH} = V_{DD} = 3.0$ V | -10 | — | 10 | μ A |
| Low Level Input Current ³ | I_{IL} | $V_{IL} = 0$ V, $V_{DD} = 3.0$ V | -10 | — | 10 | μ A |
| High Level Output Voltage ⁴ | V_{OH} | $I_{OH} = -500$ μ A | $V_{DD}-0.4$ | — | — | V |
| Low Level Output Voltage ⁴ | V_{OL} | $I_{OL} = 500$ μ A | — | — | 0.4 | V |
| High Level Output Voltage ⁵ | V_{OH} | $I_{OH} = -10$ mA | $V_{DD}-0.4$ | — | — | V |
| Low Level Output Voltage ⁵ | V_{OL} | $I_{OL} = 10$ mA | — | — | 0.4 | V |

Notes:

1. Measured with load on XOUT pin of 10 pF and $f_{REF} = 13$ MHz. Limits with XEN = 1 guaranteed by characterization.
2. RF1 VCO is used for receive mode, RF2 and IF VCOs are used for transmit mode. Center frequencies for each VCO are as follows: RF1 = 1.9 GHz, RF2 = 1.35 GHz, IF = 825 MHz.
3. For pins SCLK, SDI, \overline{SEN} , XEN, and \overline{PDN} .
4. For pins SDO, XOUT.
5. For pins DIAG1, DIAG2.

Table 4. AC Characteristics

($V_{DD} = 2.7$ to 3.0 V, $T_A = -20$ to 85 °C)

| Parameter | Symbol | Test Condition | Min | Typ | Max | Unit |
|--|------------|--------------------|-----|-----|-----|------------|
| SCLK Cycle Time | t_{CLK} | Figure 1, 3 | 35 | — | — | ns |
| SCLK Rise Time | t_R | Figure 1, 3 | — | — | 50 | ns |
| SCLK Fall Time | t_F | Figure 1, 3 | — | — | 50 | ns |
| SCLK High Time | t_{HI} | Figure 1, 3 | 10 | — | — | ns |
| SCLK Low Time | t_{LO} | Figure 1, 3 | 10 | — | — | ns |
| \overline{PDN} Rise Time | t_{PR} | Figure 2 | — | — | 10 | ns |
| \overline{PDN} Fall Time | t_{PF} | Figure 2 | — | — | 10 | ns |
| SDI Setup Time to SCLK \uparrow | t_{SU} | Figure 3 | 15 | — | — | ns |
| SDI Hold Time from SCLK \uparrow | t_{HOLD} | Figure 3 | 10 | — | — | ns |
| $\overline{SEN}\downarrow$ to SCLK \uparrow Delay Time | t_{EN1} | Figure 3 | 10 | — | — | ns |
| SCLK \uparrow to $\overline{SEN}\uparrow$ Delay Time | t_{EN2} | Figure 3, 4 | 12 | — | — | ns |
| $\overline{SEN}\uparrow$ to SCLK \uparrow Delay Time | t_{EN3} | Figure 3, 4 | 12 | — | — | ns |
| \overline{SEN} Pulse Width | t_W | Figure 3, 4 | 10 | — | — | ns |
| SCLK \downarrow to SDO Time | t_{CA} | Figure 4 | — | — | 27 | ns |
| Digital Input Pin Capacitance ¹ | | | — | — | 5 | pF |
| Allowable Board Capacitance ² | | | — | — | 1 | pF |
| XIN Input Resistance ³ | R_{XIN} | | 20 | 30 | 40 | k Ω |
| XIN Input Capacitance ³ | C_{XIN} | | 3.5 | 5 | 7 | pF |
| XIN Input Sensitivity ³ | V_{REF} | | 0.5 | — | — | V_{PP} |
| XIN Input Frequency ^{3,4} | f_{REF} | XSEL = 0, DIV2 = 0 | — | 13 | — | MHz |
| | | XSEL = 1, DIV2 = 1 | — | 26 | — | MHz |

Notes:

1. For pins SCLK, SDI, \overline{SEN} , XEN, and \overline{PDN} .
2. For pins CKN, CKP, ION, and IOP.
3. For XIN pins (Si4133T pin 7 and Si4201 pin 7).
4. The XSEL bit controls an internal divide-by-two circuit on the Si4201 and does not affect the XOUT pin. The DIV2 bit controls an internal divide-by-two circuit on the Si4133T.

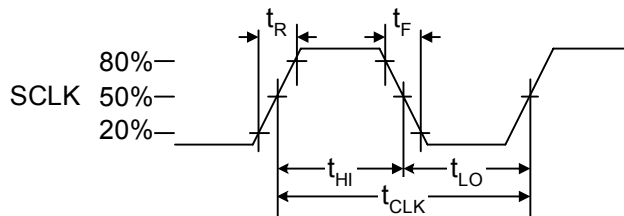

Figure 1. SCLK Timing Diagram

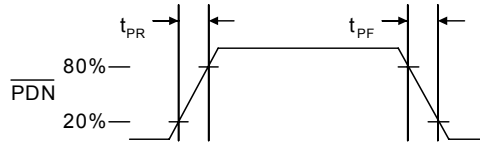

Figure 2. PDN Timing Diagram

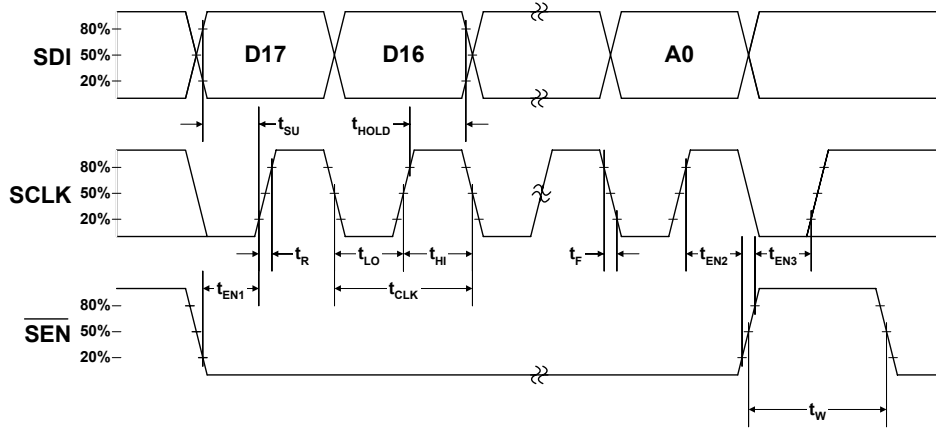

Figure 3. Serial Interface Write Timing Diagram

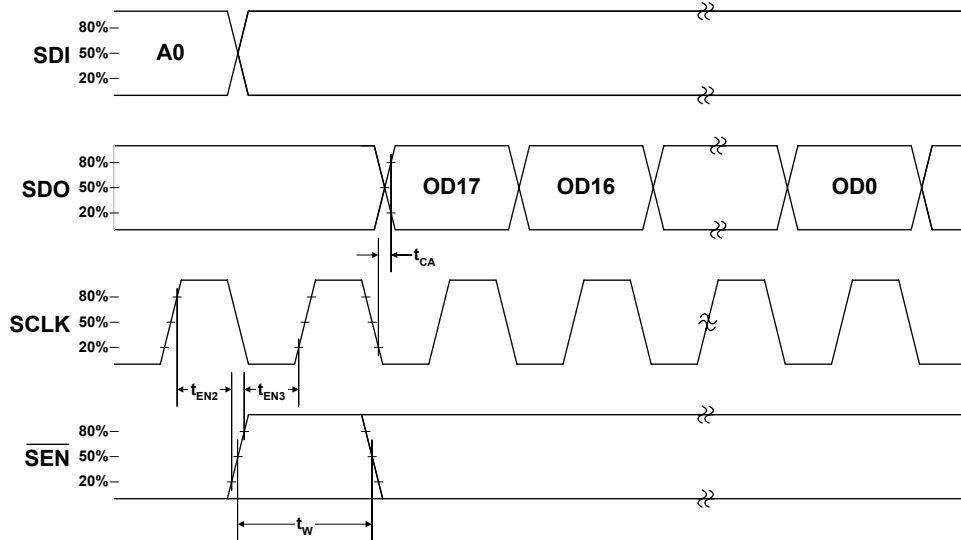

Figure 4. Serial Interface Read Timing Diagram

Table 5. Receiver Characteristics

($V_{DD} = 2.7$ to 3.0 V, $T_A = -20$ to 85 °C)

| Parameter | Symbol | Test Condition | Min | Typ | Max | Unit |
|---|------------|--|------|------|------|------|
| GSM Input Frequency ¹ | f_{IN} | GSM 850 band | 869 | — | 894 | MHz |
| | | E-GSM 900 band | 925 | — | 960 | MHz |
| DCS or PCS Input Frequency ¹ | | DCS 1800 band | 1805 | — | 1880 | MHz |
| | | PCS 1900 band | 1930 | — | 1990 | MHz |
| Noise Figure at 25 °C ^{2,3} | NF_{25} | GSM 850 band | — | 2.6 | 3.3 | dB |
| | | E-GSM 900 band | — | 2.7 | 3.4 | dB |
| | | DCS 1800 band | — | 3.2 | 3.9 | dB |
| | | PCS 1900 band | — | 3.6 | 4.3 | dB |
| Noise Figure at 75 °C ^{2,3} | NF_{75} | GSM 850 band | — | 3.3 | 4.0 | dB |
| | | E-GSM 900 band | — | 3.4 | 4.1 | dB |
| | | DCS 1800 band | — | 4.1 | 4.8 | dB |
| | | PCS 1900 band | — | 4.8 | 5.5 | dB |
| Noise Figure at 85 °C ^{2,3} | NF_{85} | GSM 850 band | — | 3.4 | 4.1 | dB |
| | | E-GSM 900 band | — | 3.5 | 4.2 | dB |
| | | DCS 1800 band | — | 4.5 | 5.2 | dB |
| | | PCS 1900 band | — | 5.1 | 5.8 | dB |
| 3 MHz Input Desensitization ^{2,3,4} | DES_3 | GSM input | -25 | -21 | — | dBm |
| | | DCS / PCS inputs | -28 | -25 | — | dBm |
| 20 MHz Input Desensitization ^{2,3,4} | DES_{20} | GSM input | -20 | -16 | — | dBm |
| | | DCS / PCS inputs | -19 | -15 | — | dBm |
| Input IP2 ² | IP2 | $ f_{1,2} - f_0 \geq 6$ MHz, $ f_2 - f_1 = 100$ kHz | 29 | 40 | — | dBm |
| Input IP3 ² | IP3 | $ f_2 - f_1 \geq 800$ kHz, $f_0 = 2f_1 - f_2$ | -18 | -12 | — | dBm |
| Image Rejection ² | IR | GSM input | 28 | 35 | — | dB |
| | | DCS / PCS inputs | 28 | 40 | — | dB |
| 1 dB Input Compression ^{2,5} | CP_{MAX} | GSM input | -28 | -23 | — | dBm |
| | | DCS / PCS inputs | -27 | -22 | — | dBm |
| 1 dB Input Compression ^{2,6} | CP_{MIN} | GSM input | -23 | -18 | — | dBm |
| | | DCS / PCS inputs | -23 | -18 | — | dBm |
| Minimum Voltage Gain ^{2,6,7} | G_{MIN} | GSM input | 4.5 | 8.5 | 12.5 | dB |
| | | DCS / PCS inputs | 11.5 | 15.5 | 19.5 | dB |
| Maximum Voltage Gain ^{2,7} | G_{MAX} | GSM input | 100 | 104 | 108 | dB |
| | | DCS / PCS inputs | 96 | 102 | 106 | dB |

Table 5. Receiver Characteristics (Continued) $(V_{DD} = 2.7$ to 3.0 V, $T_A = -20$ to 85 °C)

| Parameter | Symbol | Test Condition | Min | Typ | Max | Unit |
|--|-------------------|------------------|------|------|------|------------|
| LNA Voltage Gain ^{3,8} | G_{LNA} | GSM input | — | 17 | — | dB |
| | | DCS / PCS inputs | — | 15 | — | dB |
| LNA Gain Control Range | ΔG_{LNA} | GSM input | 13 | 17 | 21 | dB |
| | | DCS / PCS inputs | 4 | 8 | 12 | dB |
| Analog PGA Control Range | ΔG_{APGA} | | 13 | 16 | 19 | dB |
| Analog PGA Step Size | | | 3.2 | 4.0 | 4.8 | dB |
| Digital PGA Control Range | ΔG_{DPGA} | | — | 63 | — | dB |
| Digital PGA Step Size | | | — | 1 | — | dB |
| Maximum Differential Output Voltage ⁹ | | DACFS[1:0] = 00 | 0.8 | 1.0 | 1.2 | V_{PPD} |
| | | DACFS[1:0] = 01 | 1.6 | 2.0 | 2.4 | V_{PPD} |
| | | DACFS[1:0] = 10 | 2.8 | 3.5 | 4.2 | V_{PPD} |
| Output Common Mode Voltage ⁹ | | DACCM[1:0] = 00 | 0.8 | 1.0 | 1.2 | V |
| | | DACCM[1:0] = 01 | 1.05 | 1.25 | 1.45 | V |
| | | DACCM[1:0] = 10 | 1.15 | 1.35 | 1.55 | V |
| Differential Output Offset Voltage ^{9,10} | | | — | — | 50 | mV |
| Baseband Gain Error ^{9,10} | | | — | — | 1 | % |
| Baseband Phase Error ^{10,11} | | | — | — | 1 | deg |
| Output Load Resistance ¹⁰ | R_L | Single-ended | 10 | — | — | k Ω |
| Output Load Capacitance ¹⁰ | C_L | Single-ended | — | — | 10 | pF |
| Group Delay ¹¹ | | CSEL = 0 | — | — | 22 | μ s |
| | | CSEL = 1 | — | — | 16 | μ s |
| Differential Group Delay ¹¹ | | CSEL = 0 | — | — | 1.5 | μ s |
| | | CSEL = 1 | — | — | 1 | μ s |
| Powerup Settling Time ^{3,12} | | From powerdown | — | 200 | 220 | μ s |

Table 5. Receiver Characteristics (Continued)

($V_{DD} = 2.7$ to 3.0 V, $T_A = -20$ to 85 °C)

| Parameter | Symbol | Test Condition | Min | Typ | Max | Unit |
|--|--------|----------------|-----|-----|-----|------|
| Notes: | | | | | | |
| <ol style="list-style-type: none"> 1. GSM input pins RFIGP and RFIGN. DCS input pins RFIDP and RFIDN. PCS input pins RFIPP and RFIPN. On the Si4200DB, the PCS input pins should be used for either PCS 1900 or DCS 1800 bands. 2. Measurement is performed with a 2:1 balun ($50\ \Omega$ input, $200\ \Omega$ balanced output) and includes matching network and PCB losses. Measured at max gain ($AGAIN[2:0] = \text{max}=100_b$, $LNAG[1:0] = \text{max}=01_b$, $LNAC[1:0] = \text{max}=01_b$) unless otherwise noted. Noise figure measurements are referred to 290 °K. Insertion loss of the balun is removed. 3. Specifications are guaranteed by characterization. 4. Wanted signal at balun input is -102 dBm. SNR at baseband output is 9 dB. 5. $AGAIN[2:0] = \text{min}=000_b$, $LNAG[1:0] = \text{max}=01_b$, $LNAC[1:0] = \text{max}=01_b$. 6. $AGAIN[2:0] = \text{min}=000_b$, $LNAG[1:0] = \text{min}=00_b$, $LNAC[1:0] = \text{min}=00_b$. 7. Voltage gain is defined as the differential rms voltage at the RXIP/RXIN pins or RXQP/RXQN pins divided by the rms voltage at the balun input with $DACFS[1:0] = 01$ and $CSEL = 1$. Gain is 1.5 dB higher with $CSEL = 0$. Minimum and maximum values do not include the variation in the Si4201 DAC full scale voltage (also see Maximum Differential Output Voltage specification). 8. Voltage gain is defined as the differential rms voltage at the LNA output divided by the rms voltage at the balun output. 9. Output pins RXIP, RXIN, RXQP, RXQN. 10. The baseband signal path is entirely digital. Gain, phase, and offset errors at the baseband outputs are because of the Si4201 D/A converters. Offsets can be measured and calibrated out. See ZERODEL[2:0] in the register description. 11. Group delay is measured from antenna input to baseband outputs. Differential group delay is measured in-band. 12. Includes settling time of the Si4133T frequency synthesizer. Settling to 5 degrees phase error measured at RXIP, RXIN, RXQP, and RXQN pins. | | | | | | |

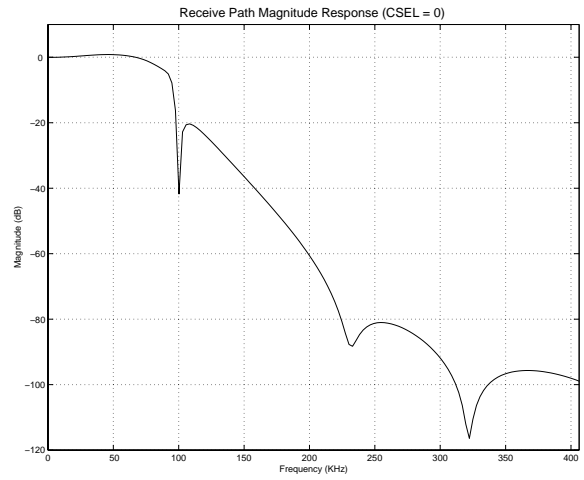

Figure 5. Receive Path Magnitude Response (CSEL = 0)

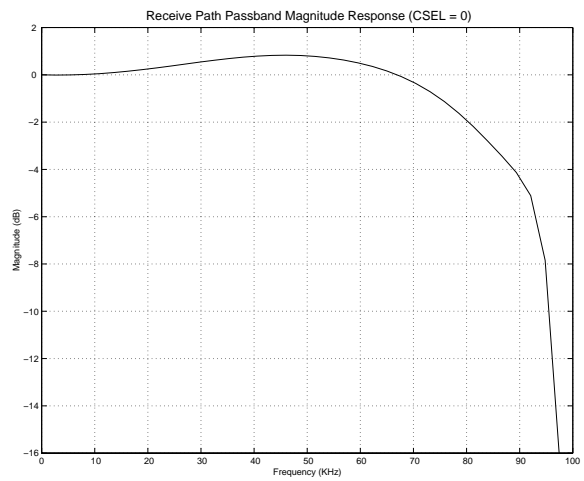

Figure 6. Receive Path Passband Magnitude Response (CSEL = 0)

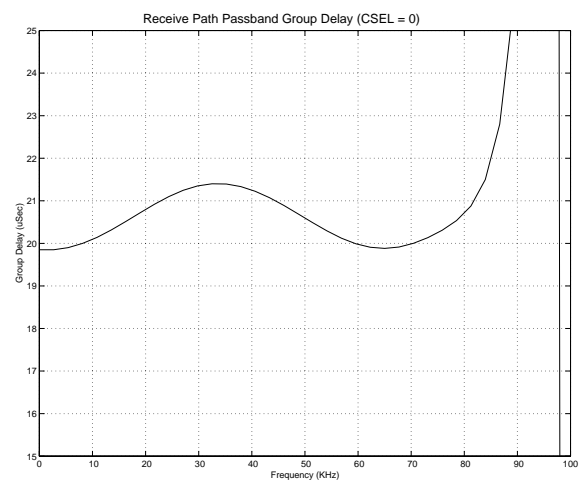

Figure 7. Receive Path Passband Group Delay (CSEL = 0)

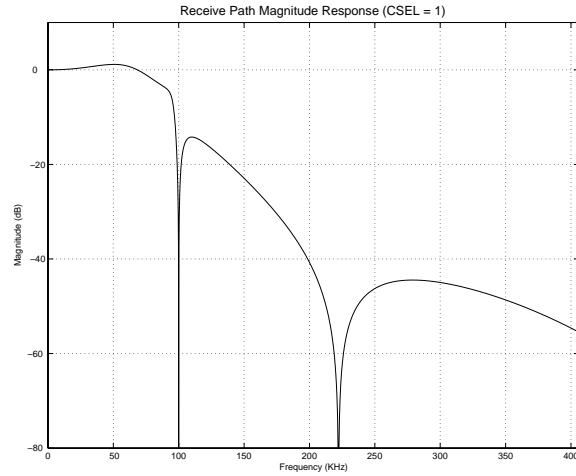

Figure 8. Receive Path Magnitude Response (CSEL = 1)

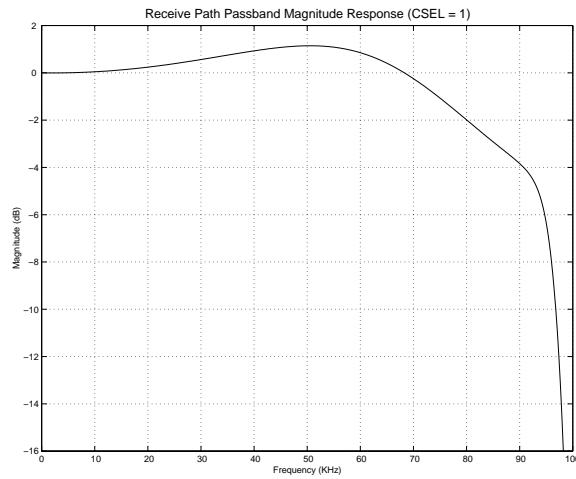

Figure 9. Receive Path Passband Magnitude Response (CSEL = 1)

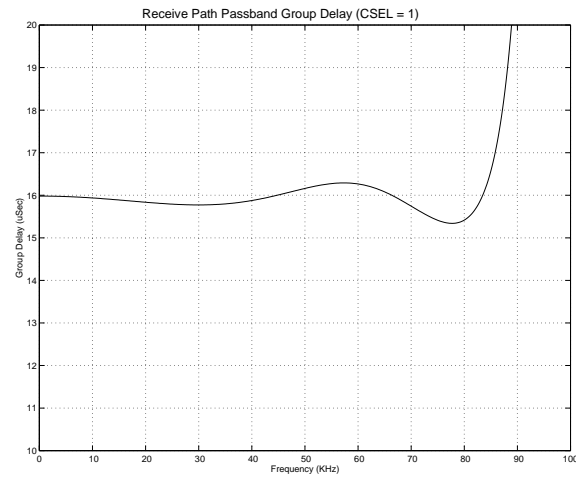

Figure 10. Receive Path Passband Group Delay (CSEL = 1)

Table 6. Transmitter Characteristics $(V_{DD} = 2.7 \text{ to } 3.0 \text{ V}, T_A = -20 \text{ to } 85 \text{ }^\circ\text{C})$

| Parameter | Symbol | Test Condition | Min | Typ | Max | Unit |
|--|--------|---------------------------------|------|------|------|------------------------|
| RFOG Output Frequency ¹ | | GSM 850 band | 824 | — | 849 | MHz |
| | | E-GSM 900 band | 880 | — | 915 | MHz |
| RFOD Output Frequency ² | | DCS 1800 band | 1710 | — | 1785 | MHz |
| | | PCS 1900 band | 1850 | — | 1910 | MHz |
| I/Q Differential Input Swing ^{3,4} | | | 0.88 | — | 2.2 | V_{PPD} |
| I/Q Input Common-Mode ³ | | | 1.1 | — | 1.4 | V |
| I/Q Differential Input Resistance ^{3,4} | | BBG[1:0] = 11 _b | 26 | 30 | 35 | k Ω |
| | | BBG[1:0] = 00 _b | 22 | 25 | 29 | k Ω |
| | | BBG[1:0] = 01 _b | 17 | 20 | 23 | k Ω |
| | | Powered down | — | Hi-Z | — | k Ω |
| I/Q Input Capacitance ^{3,5} | | | — | — | 5 | pF |
| I/Q Input Bias Current ³ | | | 13 | 16 | 19 | μA |
| Sideband Suppression | | 67.7 kHz sinusoid | — | -46 | -34 | dBc |
| Carrier Suppression | | 67.7 kHz sinusoid | — | -48 | -33 | dBc |
| IM3 Suppression | | 67.7 kHz sinusoid | — | -57 | -50 | dBc |
| Phase Error ⁵ | | | — | 1.9 | 3.0 | $^\circ_{\text{rms}}$ |
| | | | — | 5 | 10 | $^\circ_{\text{PEAK}}$ |
| TXVCO Pushing ^{1,2} | | Open loop | — | 100 | — | kHz/V |
| TXVCO Pulling ^{1,2} | | VSWR 2:1, all phases, open loop | — | 200 | — | kHz _{PP} |
| RFOG Output Modulation Spectrum ^{1,6} | | 400 kHz offset | — | -65 | -63 | dBc |
| | | 1.8 MHz offset | — | -70 | -68 | dBc |
| RFOD Output Modulation Spectrum ^{2,6} | | 400 kHz offset | — | -65 | -63 | dBc |
| | | 1.8 MHz offset | — | -70 | -65 | dBc |
| RFOG Output Phase Noise ^{1,5,7} | | 10 MHz offset | — | -160 | -155 | dBc/Hz |
| | | 20 MHz offset | — | -166 | -164 | dBc/Hz |
| RFOD Output Phase Noise ^{2,5,7} | | 20 MHz offset | — | -163 | -157 | dBc/Hz |
| RFOG Output Power Level ¹ | | $Z_L = 50 \Omega$ | 7 | 9 | 11 | dBm |
| RFOD Output Power Level ² | | $Z_L = 50 \Omega$ | 6 | 8 | 10 | dBm |
| RF Output Harmonic Suppression ^{1,2} | | 2nd harmonic | — | — | -20 | dBc |
| | | 3rd harmonic | — | — | -10 | dBc |

Table 6. Transmitter Characteristics (Continued)

($V_{DD} = 2.7$ to 3.0 V, $T_A = -20$ to 85 °C)

| Parameter | Symbol | Test Condition | Min | Typ | Max | Unit |
|--|--------|----------------|-----|-----|-----|------|
| Powerup Settling Time ^{5,8} | | From powerdown | — | — | 150 | μs |
| Notes: <ol style="list-style-type: none"> 1. Measured at RFOG pin. 2. Measured at RFOD pin. 3. Input pins TXIP, TXIN, TXQP, and TXQN. 4. Differential Input Swing is programmable with the BBG[1:0] bits in register 04h. Program these bits to the closest appropriate value. The I/Q Input Resistance scales inversely with the BBG[1:0] setting. 5. Specifications are guaranteed by characterization. 6. Measured with pseudo-random pattern. Carrier power and noise power < 1.8 MHz measured with 30 kHz RBW. Noise power ≥ 1.8 MHz measured with 100 kHz RBW. 7. Measured with all 1s pattern. 8. Includes settling time of the Si4133T frequency synthesizer. Settling time measured at the RFOD and RFOG pins to 0.1 ppm frequency error. | | | | | | |

Table 7. Frequency Synthesizer Characteristics(V_{DD} = 2.7 to 3.0 V, T_A = -20 to 85 °C)

| Parameter | Symbol | Test Condition | Min | Typ | Max | Unit |
|--|------------------|--|--------|-----|--------|-------|
| RF1 VCO Frequency ¹ | f _{RF1} | GSM 850 band | 1737.8 | — | 1787.8 | MHz |
| | | E-GSM 900 band | 1849.8 | — | 1919.8 | MHz |
| | | DCS 1800 band | 1804.9 | — | 1879.9 | MHz |
| | | PCS 1900 band | 1929.9 | — | 1989.9 | MHz |
| RF2 VCO Frequency ¹ | f _{RF2} | GSM 850 band | 1272 | — | 1297 | MHz |
| | | E-GSM 900 | 1279 | — | 1314 | MHz |
| | | DCS 1800 band | 1327 | — | 1402 | MHz |
| | | PCS 1900 band | 1423 | — | 1483 | MHz |
| IF VCO Frequency ¹ | f _{IF} | GSM 850 band | — | 896 | — | MHz |
| | | E-GSM 900 band 880–895 MHz 900–915 MHz | — | 798 | — | MHz |
| | | E-GSM 900 band 895–900 MHz | — | 790 | — | MHz |
| | | DCS 1800 band | — | 766 | — | MHz |
| | | PCS 1900 band | — | 854 | — | MHz |
| RF1 PLL Phase Detector Update Frequency | f _φ | GSM input, RFUP = 0 | — | 200 | — | kHz |
| | | DCS/PCS inputs, RFUP = 1 | — | 100 | — | kHz |
| IF and RF2 PLL Phase Detector Update Frequency | f _φ | | — | 200 | — | kHz |
| RF1 VCO Nominal Capacitance ^{2,3} | C _{NOM} | | — | 4.3 | — | pF |
| RF2 VCO Nominal Capacitance ^{2,3} | | | — | 4.8 | — | pF |
| IF VCO Nominal Capacitance ^{2,3} | | | — | 6.5 | — | pF |
| RF1 VCO Package Inductance ^{2,3} | L _{PKG} | | — | 1.5 | — | nH |
| RF2 VCO Package Inductance ^{2,3} | | | — | 1.5 | — | nH |
| IF VCO Package Inductance ^{2,3} | | | — | 1.6 | — | nH |
| RF1 VCO Pushing ³ | | Open Loop | — | 500 | — | kHz/V |
| RF2 VCO Pushing ³ | | | — | 400 | — | kHz/V |
| IF VCO Pushing ³ | | | — | 300 | — | kHz/V |

Table 7. Frequency Synthesizer Characteristics (Continued)

($V_{DD} = 2.7$ to 3.0 V, $T_A = -20$ to 85 °C)

| Parameter | Symbol | Test Condition | Min | Typ | Max | Unit |
|----------------------------------|--------|--------------------------------------|-----|------|------|-------------------|
| RF1 VCO Pulling ³ | | VSWR = 2:1, all phases, open loop | — | 400 | — | kHz _{PP} |
| RF2 VCO Pulling ³ | | | — | 100 | — | kHz _{PP} |
| IF VCO Pulling ³ | | | — | 100 | — | kHz _{PP} |
| RF1 PLL Phase Noise ³ | | 3 MHz offset | — | -144 | -138 | dBc/Hz |
| RF2 PLL Phase Noise ³ | | 400 kHz offset | — | -126 | -121 | dBc/Hz |
| IF PLL Phase Noise ³ | | 400 kHz offset | — | -128 | -123 | dBc/Hz |
| RF1 PLL Spurious ³ | | 3 MHz offset | — | -95 | -83 | dBc |
| RF2 PLL Spurious ³ | | 400 kHz offset | — | -80 | -75 | dBc |
| IF PLL Spurious ³ | | 400 kHz offset | — | -80 | -70 | dBc |

Notes:

1. For the GSM input, the RF1 VCO is divided by two on the Si4200. During transmit, the IF VCO is divided by two on the Si4200. These tuning ranges are guaranteed provided the VCOs on the Si4133T are properly centered during the PCB board design phase. See “AN49: Aero Transceiver PCB Layout Guidelines” for more information.
2. See “4.4. VCO Inductor Design” on page 23..
3. Specifications are guaranteed by characterization.

2. Typical Application Schematic

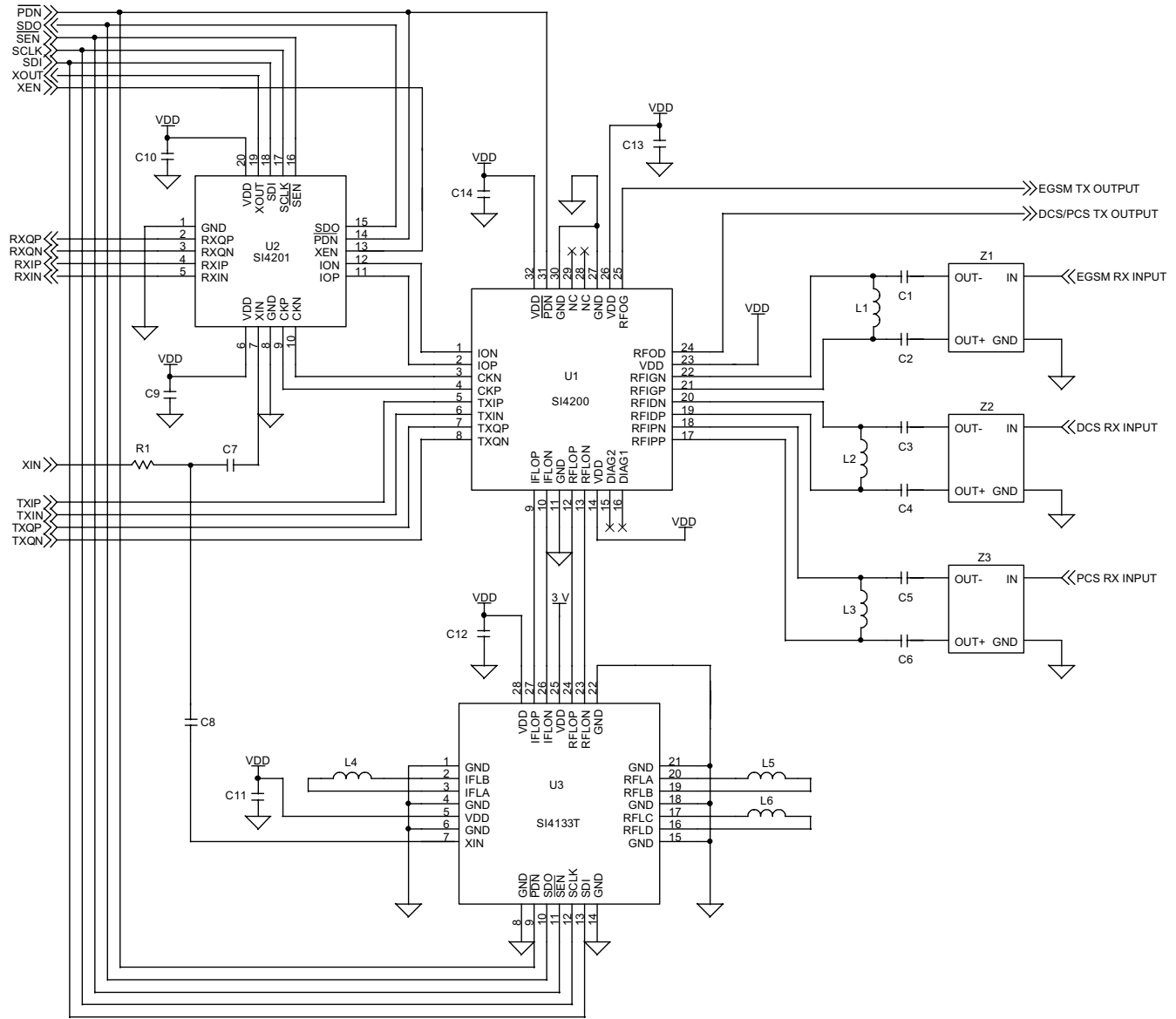

Figure 11. Typical Triple-Band Application Circuit

Notes:

1. Connect GND pad on bottom of U1–U3 to GND.
2. All VDD pins may be fed from a single supply or regulator.
3. For dual-band designs, the DCS LNA input pins (U1 pins 19–20) should be grounded. For a complete pinout, see "7. Pin Descriptions: Si4200DB-BM" on page 41.
4. See "AN49: Aero Transceiver PCB Layout Guidelines" for details on the following:
 - LNA matching network (C1–C6, L1–L3). Values should be custom tuned for a specific PCB layout and SAW filter to optimize performance.
 - Differential traces between the SAW filters (Z1–Z3) and transceiver (U1) pins 17–22.
 - Detailed SAW filter requirements.
 - L4 and PCB inductor traces L5–L6 for frequency synthesizer (U3) pins 2–3, 16–17 and 19–20.
 - CKP/CKN and IOP/ION differential traces between transceiver (U1) pins 1–4 and baseband interface (U2) pins 9–12.

3. Bill of Materials

| Component(s) | Value/Description | Supplier(s) |
|-------------------|--|--|
| C1–C2 | 1.2 pF, ± 0.1 pF, C0G (GSM 850 and E-GSM 900) | Murata GRM36C0G series Venkel C0402C0G500 series |
| C3–C4 | 1.0 pF, ± 0.1 pF, C0G (DCS 1800) | Murata GRM36C0G series Venkel C0402C0G500 series |
| C5–C6 | 1.0 pF, ± 0.1 pF, C0G (PCS 1900) | Murata GRM36C0G series Venkel C0402C0G500 series |
| C7–C8 | 100 pF, $\pm 5\%$, C0G | Venkel C0402C0G500-101JNE |
| C9, C10, C13, C14 | 22 nF, $\pm 20\%$, Z5U | |
| C11, C12 | 10 pF, $\pm 20\%$, C0G | Murata GRP1555C1H100JZ01 Venkel C0402C0G500-100JNB |
| L1 | 24 nH, $\pm 5\%$ | Murata LQW18AN series (0603 size) Murata LQW15A series (0402 size) |
| L2 | 7.5 nH, ± 0.5 nH | Murata LQW18AN series (0603 size) Murata LQW15A series (0402 size) |
| L3 | 6.8 nH, ± 0.2 nH | Murata LQW18AN series (0603 size) Murata LQW15A series (0402 size) |
| L4 | 3.9 nH, $\pm 5\%$ | Multi-layer (0402 or 0603 size) |
| L5 | Inductor for RF1 VCO | PCB Trace |
| L6 | Inductor for RF2 VCO | PCB Trace |
| R1 | 100 Ω , $\pm 5\%$ | |
| U1 | GSM Transceiver | Silicon Laboratories Si4200-BM |
| U2 | Universal Baseband Interface | Silicon Laboratories Si4201-BM |
| U3 | RF Synthesizer | Silicon Laboratories Si4133T-BM |
| Z1 | GSM 850 RX SAW Filter (150 or 200 Ω balanced output) | EPCOS B39881-B7719-C610 (6-pin, 2.0x2.5 mm) EPCOS B39881-B9001-C710 (5-pin, 1.4x2.0 mm) Murata SAFSD881MFL0T00R00 (6-pin, 2.0x2.5 mm) Murata SAFEK881MFL0T00R00 (6-pin, 1.6x2.0 mm) |
| | E-GSM 900 RX SAW Filter (150 or 200 Ω balanced output) | EPCOS B39941-B7721-C910 (6-pin, 2.0x2.5 mm) EPCOS B39941-B7820-C710 (5-pin, 1.4x2.0 mm) Murata SAFSD942MFM0T00R00 (6-pin, 2.0x2.5 mm) Murata SAFEK942MFM0T00R00 (6-pin, 1.6x2.0 mm) |
| Z2 | DCS 1800 RX SAW Filter (150 or 200 Ω balanced output) | EPCOS B39182-B7749-C910 (6-pin, 2.0x2.5 mm) EPCOS B39182-B7821-C710 (5-pin, 1.4x2.0 mm) Murata SAFSD1G84FA0T00R00 (6-pin, 2.0x2.5 mm) Murata SAFEK1G84FA0T00R00 (6-pin, 1.6x2.0 mm) |
| Z3 | PCS 1900 RX SAW Filter (150 or 200 Ω balanced output) | EPCOS B39202-B7741-C910 (6-pin, 2.0x2.5 mm) EPCOS B39202-B7825-C710 (5-pin, 1.4x2.0 mm) Murata SAFSD1G96FB0T00R00 (6-pin, 2.0x2.5 mm) Murata SAFEK1G96FA0T00R00 (6-pin, 1.6x2.0 mm) |

4. Functional Description

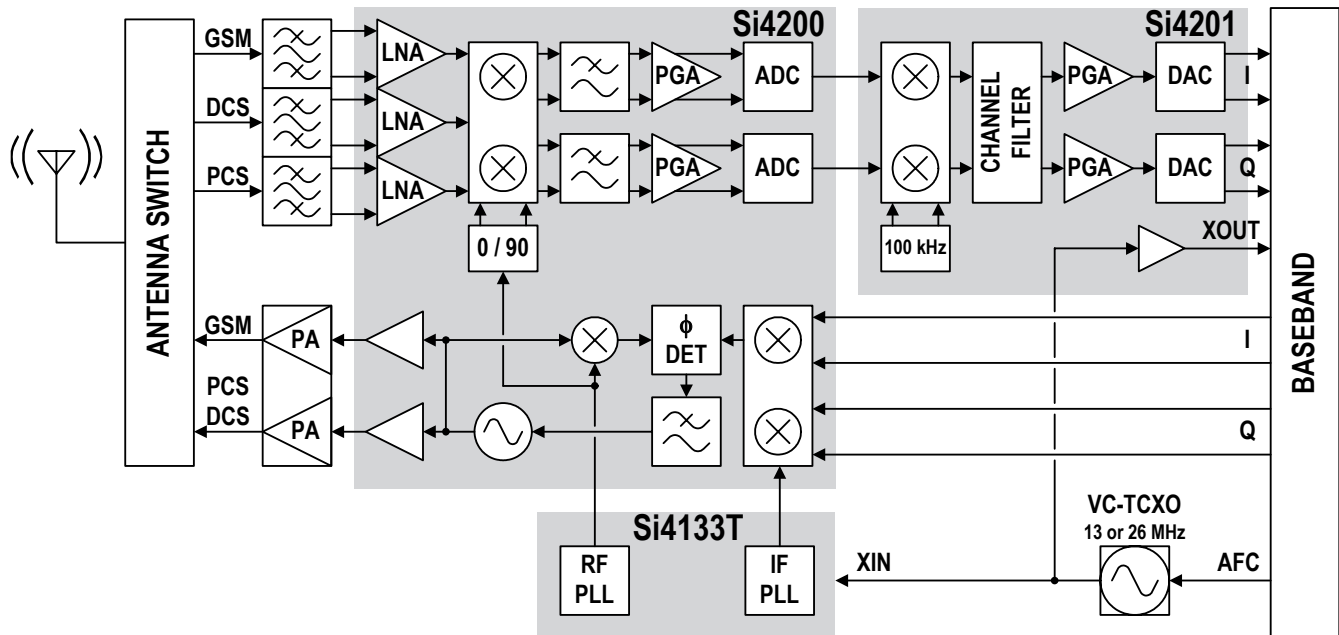

Figure 12. Aero Transceiver Block Diagram

The Aero transceiver is the industry's most integrated RF front end for multi-band GSM/GPRS digital cellular handsets and wireless data modems. The chipset consists of the Si4200 GSM transceiver, Si4201 universal baseband interface, and Si4133T dual RF synthesizer. The highly integrated solution eliminates the IF SAW filter, external low noise amplifiers (LNAs) for three bands, transmit and RF voltage controlled oscillator (VCO) modules, and more than 60 other discrete components found in conventional designs.

The high level of integration combined with quad flat no-lead package (QFN) technology and fine line CMOS process technology results in a solution with 50% less area and 80% fewer components than competing solutions. A triple-band GSM transceiver using the Aero chipset can be implemented with 24 components in less than 2.4 cm² of board area. This level of integration is an enabling force in lowering the cost, simplifying the design and manufacturing, and shrinking the form factor in next-generation GSM/GPRS voice and data terminals.

The receive section uses a digital low-IF architecture that avoids the difficulties associated with direct conversion while delivering lower solution cost and reduced complexity. The universal baseband interface is compatible with any supplier's baseband subsystem.

The transmit section is a complete up-conversion path

from the baseband subsystem to the power amplifier, and uses an offset phase locked loop (PLL) with a fully integrated transmit VCO. The frequency synthesizer uses Silicon Laboratories' proven technology, which includes integrated RF and IF VCOs, varactors, and loop filters.

The unique integer-N PLL architecture used in the Si4133T produces a transient response that is superior in speed to fractional-N architectures without suffering the high phase noise or spurious modulation effects often associated with those designs. This fast transient response makes the Aero chipset well suited to GPRS multi-slot applications where channel switching and settling times are critical.

While conventional solutions use BiCMOS or other bipolar process technologies, the Aero chipset is the industry's first cellular transceiver to be implemented in a 100% CMOS process. This brings the cost savings and extensive manufacturing capacity of CMOS to the GSM market.

4.1. Receive Section

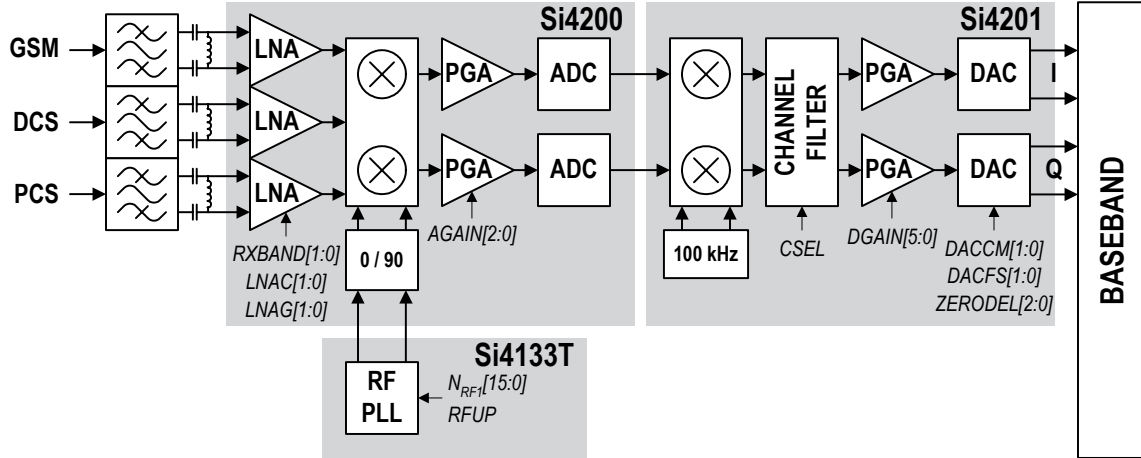

Figure 13. Receiver Block Diagram

The Aero transceiver uses a low-IF receiver architecture that allows for the on-chip integration of the channel selection filters, eliminating the external RF image reject filters and the IF SAW filter required in conventional superheterodyne architectures. Compared to a direct-conversion architecture, the low-IF architecture has a much greater degree of immunity to dc offsets that can arise from RF local oscillator (RFLO) self-mixing, 2nd-order distortion of blockers, and device $1/f$ noise. This relaxes the common-mode balance requirements on the input SAW filters and simplifies PC board design and manufacturing.

The Si4200 integrates three differential-input LNAs. The GSM input supports the GSM 850 (869–894 MHz) or E-GSM 900 (925–960 MHz) bands. The DCS input supports the DCS 1800 (1805–1880 MHz) band. The PCS input supports the PCS 1900 (1930–1990 MHz) band. For quad-band designs, SAW filters for the GSM 850 and E-GSM 900 bands should be connected to a balanced combiner that drives the GSM input for both bands. For dual-band designs using the Si4200DB-BM, the PCS input should be used for either DCS 1800 or PCS 1900 bands.

The LNA inputs are matched to the 150 or 200 Ω balanced-output SAW filters through external LC matching networks. See “AN49: Aero Transceiver PCB Layout Guidelines” for implementation details. The LNA gain is controlled with the LNAG[1:0] and LNAC[1:0] bits in register 05h.

A quadrature image-reject mixer downconverts the RF signal to a 100 kHz intermediate frequency (IF) with the RFLO from the Si4133T frequency synthesizer. The RFLO frequency is between 1737.8 and 1989.9 MHz, and is divided by two in the Si4200 for GSM 850 and E-

GSM 900 modes. The mixer output is amplified with an analog programmable gain amplifier (PGA), which is controlled with the AGAIN[2:0] bits in register 05h. The quadrature IF signal is digitized with high resolution A/D converters (ADCs).

The Si4201 downconverts the ADC output to baseband with a digital 100 kHz quadrature LO signal. Digital decimation and IIR filters perform channel selection to remove blocking and reference interference signals. The response of the IIR filter is programmable to a high selectivity setting (CSEL = 0) or a low selectivity setting (CSEL = 1). The low selectivity filter has a flatter group delay response that may be desirable where the final channelization filter is in the baseband chip. After channel selection, the digital output is scaled with a digital PGA, which is controlled with the DGAIN[5:0] bits in register 05h.

The LNAG[1:0], LNAC[1:0], AGAIN[2:0] and DGAIN[5:0] bits must be set to provide a constant amplitude signal to the baseband receive inputs. See “AN51: Aero Transceiver AGC Strategy” for more details.

DACs drive a differential analog signal onto the RXIP, RXIN, RXQP and RXQN pins to interface to standard analog-input baseband ICs. No special processing is required in the baseband for offset compensation or extended dynamic range. The receive and transmit baseband I/Q pins can be multiplexed together into a 4-wire interface. The common mode level at the receive I and Q outputs is programmable with the DACCM[1:0] bits, and the full scale level is programmable with the DACFS[1:0] bits in register 12h.

4.2. Transmit Section

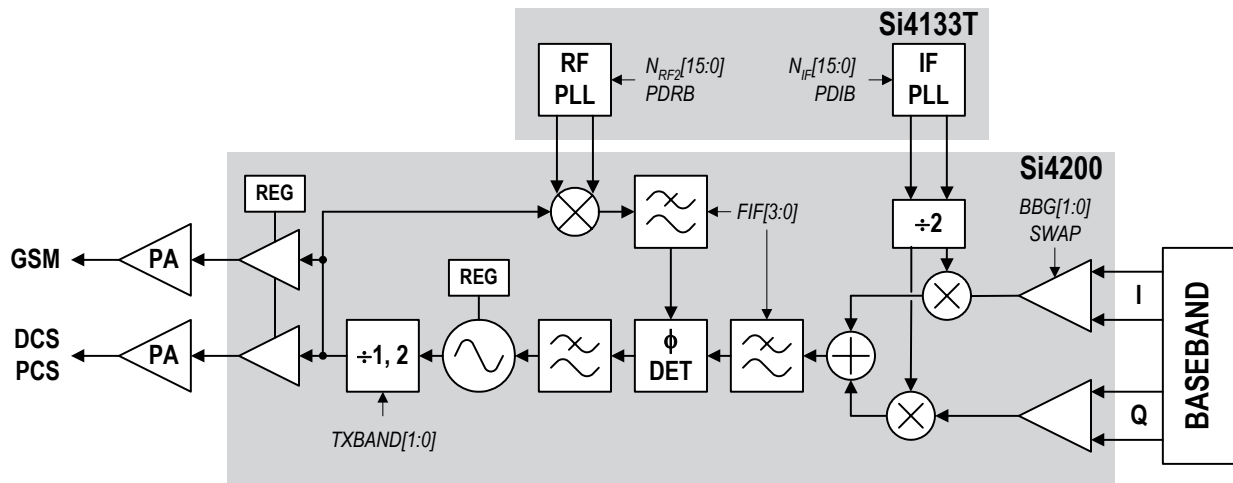

Figure 14. Transmitter Block Diagram

The transmit (TX) section consists of an I/Q baseband upconverter, an offset phase-locked loop (OPLL) and two output buffers that can drive external power amplifiers (PA), one for the GSM 850 (824 to 849 MHz) and E-GSM 900 (880 to 915 MHz) bands and one for the DCS 1800 (1710 to 1785 MHz) and PCS 1900 (1850 to 1910 MHz) bands. The OPLL requires no external filtering to attenuate transmitter noise or spurious signals in the receive band, saving both cost and power. Additionally, the output of the transmit VCO (TXVCO) is a constant-envelope signal which reduces the problem of spectral spreading caused by non-linearity in the PA.

A quadrature mixer upconverts the differential in-phase (TXIP, TXIN) and quadrature (TXQP, TXQN) signals with the IFLO to generate a SSB IF signal which is filtered and used as the reference input to the OPLL. The Si4133T generates the IFLO frequency between 766 and 896 MHz. The IFLO is divided by two to generate the quadrature LO signals for the quadrature modulator, resulting in an IF between 383 and 448 MHz. For the E-GSM 900 band, two different IFLO frequencies are required for spur management. Therefore, the IF PLL must be programmed per channel in the E-GSM 900 band. The IFLO frequencies are defined in Table 7 on page 15.

The OPLL consists of a feedback mixer, a phase detector, a loop filter, and a fully integrated TXVCO. The TXVCO is centered between the DCS 1800 and PCS 1900 bands, and its output is divided by two for the GSM 850 and E-GSM 900 bands. The Si4133T generates the RFLO frequency between 1272 and 1483 MHz. To allow a single VCO to be used for the

RFLO, high-side injection is used for the GSM 850 and E-GSM 900 bands, and low-side injection is used for the DCS 1800 and PCS 1900 bands. The I and Q signals are automatically swapped within the Si4200 when switching bands. Additionally, the SWAP bit in register 03h can be used to manually exchange the I and Q signals.

Low-pass filters before the OPLL phase detector reduce the harmonic content of the quadrature modulator and feedback mixer outputs. The cutoff frequency of the filters is programmable with the FIF[3:0] bits in register 04h and should be set to the recommended settings detailed in the register description.

4.3. Frequency Synthesizer

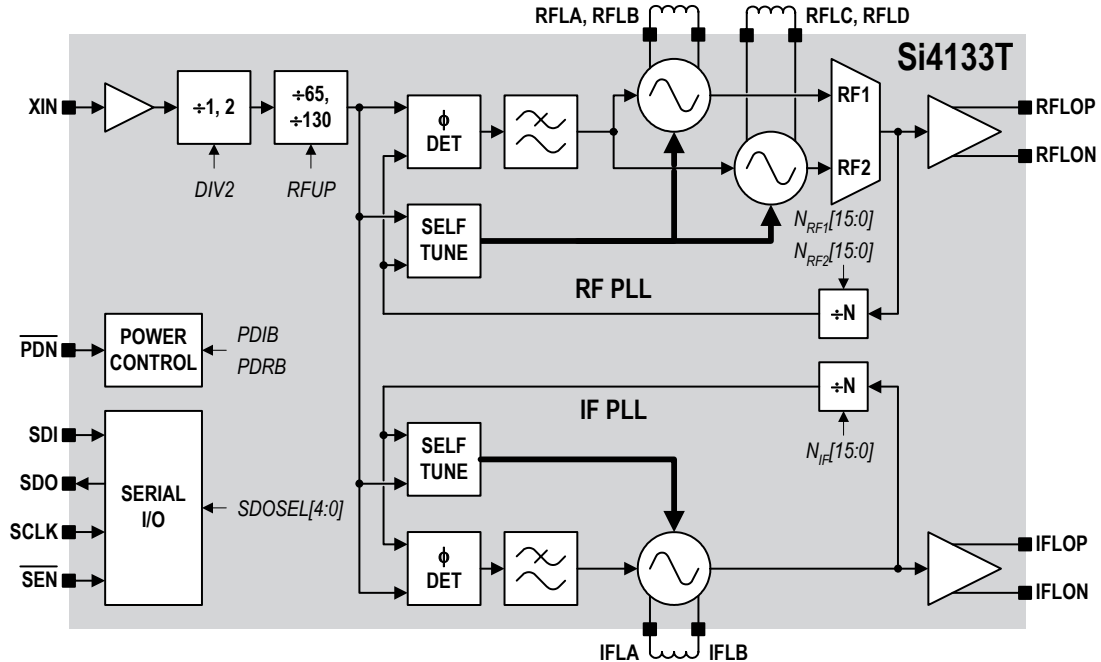

Figure 15. Si4133T Frequency Synthesizer Block Diagram

The Si4133T dual frequency synthesizer is a monolithic CMOS integrated circuit that performs IF and RF synthesis. Two complete PLLs are integrated including VCOs, varactors, resonators, loop filters, reference and VCO dividers, and phase detectors. Differential outputs for the IF and RF PLLs are provided for direct connection to the Si4200 transceiver IC. The RF PLL uses two multiplexed VCOs. The RF1 VCO is used for Receive mode, and the RF2 VCO is used for Transmit mode. The IF PLL is used only during Transmit mode.

The IF and RF output frequencies are set by programming the N-Divider registers, N_{RF1} , N_{RF2} , and N_{IF} . Programming the N-Divider register for either RF1 or RF2 automatically selects the proper VCO. The output frequency of each PLL is as follows:

$$f_{OUT} = N \times f_{\phi}$$

The DIV2 bit in Register 31h controls a programmable divider at the XIN pin to allow either a 13 or 26 MHz reference frequency. For receive mode, the RF1 PLL phase detector update rate (f_{ϕ}) should be programmed to $f_{\phi} = 100$ kHz for DCS 1800 or PCS 1900 bands, and to $f_{\phi} = 200$ kHz for GSM 850 and E-GSM 900 bands. For transmit mode, the RF2 and IF PLL phase detector update rates are always $f_{\phi} = 200$ kHz.

4.4. VCO Inductor Design

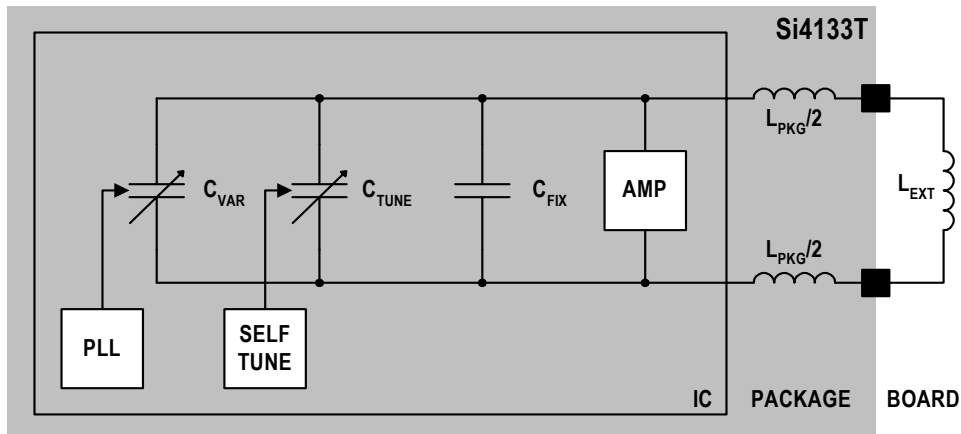

Figure 16. VCO Block Diagram

4.4.1. Determining L_{EXT}

The center frequencies for the RF1, RF2, and IF VCOs in the Si4133T are set using an external inductance (L_{EXT}). It is very important that L_{EXT} be properly designed to ensure maximum manufacturing margin for the desired VCO frequency tuning ranges. Because the total tank inductance is in the low nH range, the inductance of the package (L_{PKG}) must be considered in determining the correct external inductance.

Figure 16 shows the detailed configuration of the integrated VCOs. The total inductance (L_{TOT}) of each VCO is the sum of the external inductance (L_{EXT}) and the package inductance (L_{PKG}). The total capacitance (C_{TOT}) of each VCO is the sum of the self tuning capacitance (C_{TUNE}), the PLL varactor capacitance (C_{VAR}), and the fixed capacitance (C_{FIX}). The nominal capacitance (C_{NOM}) of each VCO is calculated with C_{TUNE} and C_{VAR} at their center values. C_{NOM} and L_{PKG} values are defined in Table 7.

The center frequency is calculated as follows:

$$f_{CEN} = \frac{1}{2\pi\sqrt{C_{NOM}(L_{PKG} + L_{EXT})}}$$

The value for the external inductor is determined by:

$$L_{EXT} = \frac{1}{(2\pi f_{CEN})^2 C_{NOM}} - L_{PKG}$$

- where f_{CEN} = desired center frequency of VCO
- C_{NOM} = nominal capacitance from Table 7.
- L_{PKG} = package inductance from Table 7.
- L_{EXT} = external inductance required

Table 8. VCO f_{CEN} Values (MHz)

| Supported Bands | RF1 VCO | RF2 VCO | IF VCO |
|--|---------|---------|--------|
| European Dual-Band (900/1800) | 1862 | 1341 | 782 |
| Triple-Band (900/1800/1900) | 1897 | 1381 | 810 |
| Quad-Band (850/900/1800/1900) or North American Dual Band (850/1900) | 1864 | 1378 | 831 |

Table 9. VCO L_{EXT} Values (nH)

| Supported Bands | RF1 VCO | RF2 VCO | IF VCO |
|--|---------|---------|--------|
| European Dual-Band (900/1800) | 0.20 | 1.43 | 4.77 |
| Triple-Band (900/1800/1900) | 0.14 | 1.27 | 4.34 |
| Quad-Band (850/900/1800/1900) or North American Dual Band (850/1900) | 0.20 | 1.28 | 4.04 |

For example, the RF1 VCO for a triple-band design requires f_{CEN} = 1897 MHz. Table 7 on page 15 shows C_{NOM} = 4.3 pF and L_{PKG} = 1.5 nH for the RF1 VCO. The above equation shows L_{EXT} = 0.14 nH should be connected between the RFLA and RFLB pins.

Please see “AN49: Aero Transceiver PCB Layout Guidelines” for details on how to implement and verify the proper value of L_{EXT}.

4.5. Serial Interface

A three-wire serial interface is provided to allow an external system controller to write the control registers for dividers, receive path gain, powerdown settings, and other controls. The serial control word is 24 bits in length, comprised of an 18-bit data field and a 6-bit address field as shown in Figure 17. A single logical register space is shared among the three chips, which is summarized in Table 10 on page 25.

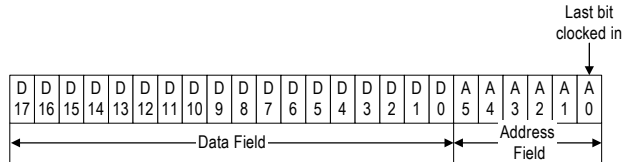

Figure 17. Serial Interface Format

The serial interface pins are intended to be connected in parallel to both the Si4201 and the Si4133T. Serial control is relayed from the Si4201 to the Si4200 over the signal interface (IOP/ION and CKP/CKN pins). All registers must be written when the PDN pin is asserted (low), except for register 22h. All serial interface pins should be held at a constant level during receive and transmit bursts to minimize spurious emissions. This includes stopping the SCLK clock. A timing diagram for the serial interface is shown in Figure 3 on page 7.

When the serial interface is enabled (i.e., when SEN is low), data and address bits on the SDI pin are clocked into an internal shift register on the rising edge of SCLK. Data in the shift register is then transferred on the rising edge of SEN into the internal data register addressed in the address field. The internal shift register ignores any leading bits before the 24 required bits. The serial interface is disabled when SEN is high.

Optionally, registers can be read as illustrated in Figure 4 on page 7. The serial output data appears on the SDO pin after writing the revision register with the address to be read. SDO is enabled when PDN = 0 on the Si4201 and when PDN = 1 on the Si4133T, allowing the SDO pin to be shared. Writing to any of the registers causes the function of SDO to revert to its previously programmed function.

4.6. XOUT Buffer

The Si4201 contains a reference clock buffer to drive the baseband input. The clock signal from the VC-TCXO is capacitively coupled to the XIN pin on the Si4201. The clock signal is not divided with the XSEL control.

The XOUT buffer is a CMOS driver stage with approximately 250 Ω of series resistance. This buffer is enabled when the XEN hardware control (pin 13 on the Si4201) is set high, independent of the PDN control pin. To achieve complete powerdown during sleep, the XEN pin must be set low, the XBUF bit in Register 12 must be set to zero, and the XPD1 bit in Register 11 must be set to one. During normal operation, these bits should set to their default values.

5. Control Registers

Table 10. Register Summary

| Reg | Name | Bit | | | | | | | | | | | | | | | | | |
|------------------|--------------------------|--------------|-------------|-------------------------|-------------------------|------------|------------------------|------|-----------|----------|------------|-------------|--------------|-------------|------------|------------|-----------|------------|-------|
| | | D17 | D16 | D15 | D14 | D13 | D12 | D11 | D10 | D9 | D8 | D7 | D6 | D5 | D4 | D3 | D2 | D1 | D0 |
| 00h | Si4200 Revision/Read | 0 | 0 | 0 | 0 | 0 | 0 | 0 | 0 | 0 | 0 | REV0[7:0] | | | | | | | |
| 01h | Reset | 0 | 0 | 0 | 0 | 0 | 0 | 0 | 0 | 0 | 0 | 0 | 0 | 0 | 0 | 0 | 0 | 0 | RESET |
| 02h | Mode | 0 | 0 | 0 | 0 | 0 | 0 | 0 | 0 | 0 | 0 | 0 | 0 | 0 | 0 | AUTO | MODE[1:0] | | |
| 03h | Config | 0 | 0 | 0 | 0 | DIAG[1:0] | | SWAP | 0 | 0 | 0 | TXBAND[1:0] | | RXBAND[1:0] | | 0 | 0 | 1 | 0 |
| 04h | Transmit | 0 | 0 | 0 | 0 | 0 | 0 | 0 | 1 | BBG[1:0] | | FIF[3:0] | | | 0 | 0 | 0 | 0 | |
| 05h | Receive | 0 | 0 | 0 | 0 | DGAIN[5:0] | | | | | 0 | AGAIN[2:0] | | | LNAC[1:0] | | LNAG[1:0] | | |
| 10h | Si4201 Revision/Read | 0 | 0 | 0 | 0 | 0 | 0 | 0 | 0 | 0 | 0 | REV1[7:0] | | | | | | | |
| 11h | Config | 0 | 0 | 0 | 0 | DPDS[2:0] | | | XPD1 | 1 | XSEL | 0 | 1 | 0 | 1 | 0 | 0 | 0 | CSEL |
| 12h | DAC Config | 0 | 0 | 0 | 0 | 0 | 0 | 0 | 1 | XBUF | 0 | ZDBS | ZERODEL[2:0] | | | DACCM[1:0] | | DACFS[1:0] | |
| 19h | Reserved | 0 | 0 | 0 | 0 | 0 | 0 | 0 | 0 | 0 | 0 | 0 | 0 | 0 | 0 | 0 | 0 | 0 | |
| Master Registers | 20h | RX Master #1 | RXBAND[1:0] | | N _{RF1} [15:0] | | | | | | | | | | | | | | |
| | 21h | RX Master #2 | 0 | DPDS[2:0] | | | LNAC[1:0] | | LNAG[1:0] | | AGAIN[2:0] | | | 0 | DGAIN[5:0] | | | | |
| | 22h | RX Master #3 | 0 | 0 | 0 | 0 | 0 | 0 | 0 | 0 | 0 | 0 | 0 | DGAIN[5:0] | | | | | |
| | 23h | TX Master #1 | TXBAND[1:0] | | N _{RF2} [15:0] | | | | | | | | | | | | | | |
| | 24h | TX Master #2 | FIF[3:0] | | | | N _{IF} [13:0] | | | | | | | | | | | | |
| 30h | Si4133T Revision/Read | 0 | 0 | 0 | 0 | 0 | 0 | 0 | 0 | 0 | 0 | REV3[7:0] | | | | | | | |
| 31h | Config | 0 | 0 | 0 | SDOSEL[3:0] | | | | 0 | 0 | 0 | 0 | 0 | 0 | RFUP | DIV2 | 0 | 0 | 1 |
| 32h | Powerdown | 0 | 0 | 0 | 0 | 0 | 0 | 0 | 0 | 0 | 0 | 0 | 0 | 0 | 0 | 0 | PDIB | PDRB | |
| 33h | RF1 N Divider | 0 | 0 | N _{RF1} [15:0] | | | | | | | | | | | | | | | |
| 34h | RF2 N Divider | 0 | 0 | N _{RF2} [15:0] | | | | | | | | | | | | | | | |
| 35h | IF N Divider | 0 | 0 | N _{IF} [15:0] | | | | | | | | | | | | | | | |
| 3Ah | Reserved | 0 | 0 | 0 | 0 | 0 | 0 | 0 | 0 | 0 | 0 | 0 | 0 | 0 | 0 | 1 | 0 | 0 | 1 |
| 3Eh | Reserved | 0 | 0 | 0 | 0 | 0 | 0 | 0 | 0 | 0 | 0 | 0 | 0 | 0 | 0 | 1 | 1 | 1 | 1 |
| 3Fh | Reserved | 0 | 0 | 0 | 0 | 0 | 0 | 0 | 0 | 0 | 0 | 0 | 0 | 0 | 1 | 0 | 0 | 0 | 0 |

Notes:

- Any register not listed here is reserved and should not be written. Writing to reserved registers may result in unpredictable behavior.
- Master registers 20h to 24h simplify programming the Aero™ transceiver to support initiation of receive (RX) and transmit (TX) operations with only two register writes.
- See “AN50: Aero Transceiver Programming Guide” for detailed instructions on register programming.

Register 00h. Revision/Read (Si4200)

| Bit | D17 | D16 | D15 | D14 | D13 | D12 | D11 | D10 | D9 | D8 | D7 | D6 | D5 | D4 | D3 | D2 | D1 | D0 |
|------|-----|-----|-----|-----|-----|-----|-----|-----|----|----|-----------|----|----|----|----|----|----|----|
| Name | 0 | 0 | 0 | 0 | 0 | 0 | 0 | 0 | 0 | 0 | REV0[7:0] | | | | | | | |

| Bit | Name | Function |
|------|-----------|---|
| 17:8 | Reserved | Read as zero. |
| 7:0 | REV0[7:0] | Si4200 Revision (read only). 00h = Si4200 revision A 01h = Si4200 revision B 02h = Si4200 revision C 03h = Si4200 revision D 14h = Si4200DB revision E (dual-band) 05h = Si4200 revision F (triple-band) |

Note: Registers on the Si4200 can be read by writing this register with the address of the register to be read.

Register 01h. Reset (Si4200/Si4201)

| Bit | D17 | D16 | D15 | D14 | D13 | D12 | D11 | D10 | D9 | D8 | D7 | D6 | D5 | D4 | D3 | D2 | D1 | D0 |
|------|-----|-----|-----|-----|-----|-----|-----|-----|----|----|----|----|----|----|----|----|----|-------|
| Name | 0 | 0 | 0 | 0 | 0 | 0 | 0 | 0 | 0 | 0 | 0 | 0 | 0 | 0 | 0 | 0 | 0 | RESET |

| Bit | Name | Function |
|------|----------|--|
| 17:1 | Reserved | Program to zero. |
| 0 | RESET | Chip Reset. 0 = Normal operation (default). 1 = Reset all registers to default values. Note: See "5. Control Registers" on page 25. for more details. This register must be written to 0 twice after a reset operation. This bit does not reset Si4133T registers 30h to 35h. |

Register 02h. Mode Control (Si4200/Si4201)

| Bit | D17 | D16 | D15 | D14 | D13 | D12 | D11 | D10 | D9 | D8 | D7 | D6 | D5 | D4 | D3 | D2 | D1 | D0 |
|-------------|-----|-----|-----|-----|-----|-----|-----|-----|----|----|----|----|----|----|----|------|-----------|----|
| Name | 0 | 0 | 0 | 0 | 0 | 0 | 0 | 0 | 0 | 0 | 0 | 0 | 0 | 0 | 0 | AUTO | MODE[1:0] | |

| Bit | Name | Function |
|------|-----------|--|
| 17:3 | Reserved | Program to zero. |
| 2 | AUTO | Automatic Mode Select. 0 = Manual. Mode is controlled by MODE[1:0] bits (default). 1 = Automatic. Last register write to N _{RF1} implies RX mode; Last register write to N _{RF2} implies TX mode. MODE[1:0] bits are ignored. |
| 1:0 | MODE[1:0] | Transmit/Receive/Calibration Mode Select. 00 = Receive mode (default). 01 = Transmit mode. 10 = Calibration mode. 11 = Reserved. Note: These bits are valid only when AUTO = 0. |

Note: Calibration must be performed each time the power supply is applied. To initiate the calibration mode, set MODE[1:0] = 10, and pulse the PDN pin high for at least 150 μ s.

Register 03h. Configuration (Si4200)

| Bit | D17 | D16 | D15 | D14 | D13 | D12 | D11 | D10 | D9 | D8 | D7 | D6 | D5 | D4 | D3 | D2 | D1 | D0 |
|-------------|-----|-----|-----|-----|-----------|------|-----|-----|----|----|-------------|-------------|----|----|----|----|----|----|
| Name | 0 | 0 | 0 | 0 | DIAG[1:0] | SWAP | 0 | 0 | 0 | 0 | TXBAND[1:0] | RXBAND[1:0] | 0 | 0 | 1 | 0 | | |

| Bit | Name | Function | | | | | | | | | | | | | | | |
|-------|--------------|--|--|--------------|--------------|------|-----|---------------|------|-----|------|------|------|-----|------|------|------|
| 17:14 | Reserved | Program to zero. | | | | | | | | | | | | | | | |
| 13:12 | DIAG[1:0] | DIAG1/DIAG2 Output Select. <table border="0"> <tr> <td></td> <td style="text-align: center;"><u>DIAG1</u></td> <td style="text-align: center;"><u>DIAG2</u></td> </tr> <tr> <td>00 =</td> <td>LOW</td> <td>LOW (default)</td> </tr> <tr> <td>01 =</td> <td>LOW</td> <td>HIGH</td> </tr> <tr> <td>10 =</td> <td>HIGH</td> <td>LOW</td> </tr> <tr> <td>11 =</td> <td>HIGH</td> <td>HIGH</td> </tr> </table> <p>Note: These pins can be used to control antenna switch functions. These bits must be programmed with the PDN pin is zero. The DIAG1/DIAG2 pins are held at the desired value regardless of the state of the PDN pin.</p> | | <u>DIAG1</u> | <u>DIAG2</u> | 00 = | LOW | LOW (default) | 01 = | LOW | HIGH | 10 = | HIGH | LOW | 11 = | HIGH | HIGH |
| | <u>DIAG1</u> | <u>DIAG2</u> | | | | | | | | | | | | | | | |
| 00 = | LOW | LOW (default) | | | | | | | | | | | | | | | |
| 01 = | LOW | HIGH | | | | | | | | | | | | | | | |
| 10 = | HIGH | LOW | | | | | | | | | | | | | | | |
| 11 = | HIGH | HIGH | | | | | | | | | | | | | | | |
| 11 | SWAP | Transmit I/Q Swap. 0 = Normal (default). 1 = Swap I and Q for TXIP, TXIN, TXQP and TXQN pins. | | | | | | | | | | | | | | | |
| 10:8 | Reserved | Program to zero. | | | | | | | | | | | | | | | |
| 7:6 | TXBAND[1:0] | Transmit Band Select. 00 = GSM 850 or E-GSM 900 (default). 01 = DCS 1800. 10 = PCS 1900. 11 = Reserved. | | | | | | | | | | | | | | | |
| 5:4 | RXBAND[1:0] | Receive Band Select. 00 = GSM input. (default), 01 = DCS input. 10 = PCS input. 11 = Reserved. | | | | | | | | | | | | | | | |
| 3:2 | Reserved | Program to zero. | | | | | | | | | | | | | | | |
| 1 | Reserved | Program to one. | | | | | | | | | | | | | | | |
| 0 | Reserved | Program to zero. | | | | | | | | | | | | | | | |

Register 04h. Transmit Control (Si4200)

| Bit | D17 | D16 | D15 | D14 | D13 | D12 | D11 | D10 | D9 | D8 | D7 | D6 | D5 | D4 | D3 | D2 | D1 | D0 |
|------|-----|-----|-----|-----|-----|-----|-----|-----|----------|----|----------|----|----|----|----|----|----|----|
| Name | 0 | 0 | 0 | 0 | 0 | 0 | 0 | 1 | BBG[1:0] | | FIF[3:0] | | | 0 | 0 | 0 | 0 | |

| Bit | Name | Function |
|-------|----------|--|
| 17:11 | Reserved | Program to zero. |
| 10 | Reserved | Program to one. |
| 9:8 | BBG[1:0] | TX Baseband Input Full Scale Differential Input Voltage. 10 = Reserved. 11 = 2.0 V _{PPD} . 00 = 1.7 V _{PPD} (default). 01 = 1.3 V _{PPD} . Note: Refer to Table 6 for minimum and maximum values. Set this register to the nearest value. |
| 7:4 | FIF[3:0] | TX IF Filter Cutoff Frequency. 0111 = Use for GSM 850, E-GSM 900 and PCS 1900 bands. 0110 = Use for DCS 1800 band. Note: Use the recommended setting for each band. Other settings reserved. |
| 3:0 | Reserved | Program to zero. |

Register 05h. Receive Gain (Si4200/Si4201)

| Bit | D17 | D16 | D15 | D14 | D13 | D12 | D11 | D10 | D9 | D8 | D7 | D6 | D5 | D4 | D3 | D2 | D1 | D0 |
|------|-----|-----|-----|-----|------------|-----|-----|-----|----|----|------------|----|----|-----------|----|-----------|----|----|
| Name | 0 | 0 | 0 | 0 | DGAIN[5:0] | | | | | 0 | AGAIN[2:0] | | | LNAC[1:0] | | LNAG[1:0] | | |

| Bit | Name | Function |
|-------|------------|---|
| 17:14 | Reserved | Program to zero. |
| 13:8 | DGAIN[5:0] | <p>Digital PGA Gain Control. 00h = 0 dB (default). 01h = 1 dB. ... 3Fh = 63 dB. Note: See "AN51: Aero Transceiver AGC Strategy" for details on setting the gain registers.</p> |
| 7 | Reserved | Program to zero. |
| 6:4 | AGAIN[2:0] | <p>Analog PGA Gain Control. 000 = 0 dB (default). 001 = 4 dB. 010 = 8 dB. 011 = 12 dB. 100 = 16 dB. 101 = Reserved. 110 = Reserved. 111 = Reserved. Note: See "AN51: Aero Transceiver AGC Strategy" for details on setting the gain registers.</p> |
| 3:2 | LNAC[1:0] | <p>LNA Bias Current Control. 00 = Minimum current (default). 01 = Maximum current. 10 = Reserved. 11 = Reserved. Note: Program these bits to the same value as same as LNAG[1:0]</p> |
| 1:0 | LNAG[1:0] | <p>LNA Gain Control. 00 = Minimum gain (default). 01 = Maximum gain. 10 = Reserved. 11 = Reserved. Notes: 1. Program these bits to the same value as same as LNAC[1:0] 2. See "AN51: Aero Transceiver AGC Strategy" for details on setting the gain registers.</p> |

Register 10h. Revision/Read (Si4201)

| Bit | D17 | D16 | D15 | D14 | D13 | D12 | D11 | D10 | D9 | D8 | D7 | D6 | D5 | D4 | D3 | D2 | D1 | D0 |
|-------------|-----|-----|-----|-----|-----|-----|-----|-----|----|----|-----------|----|----|----|----|----|----|----|
| Name | 0 | 0 | 0 | 0 | 0 | 0 | 0 | 0 | 0 | 0 | REV1[7:0] | | | | | | | |

| Bit | Name | Function |
|------|-----------|--|
| 17:8 | Reserved | Read as zero. |
| 7:0 | REV1[7:0] | Si4201 Revision (read only). 00h = Rev A. 01h = Rev B. 02h = Rev C (latest version). |

Note: Registers on the Si4201 can be read by writing this register with the address of the register to be read.

Register 11h. Configuration (Si4201)

| Bit | D17 | D16 | D15 | D14 | D13 | D12 | D11 | D10 | D9 | D8 | D7 | D6 | D5 | D4 | D3 | D2 | D1 | D0 |
|-------------|-----|-----|-----|-----|-----------|-----|-----|------|----|------|----|----|----|----|----|----|----|------|
| Name | 0 | 0 | 0 | 0 | DPDS[2:0] | | | XPD1 | 1 | XSEL | 0 | 1 | 0 | 1 | 0 | 0 | 0 | CSEL |

| Bit | Name | Function |
|-------|-----------|---|
| 17:14 | Reserved | Program to zero. |
| 13:11 | DPDS[2:0] | <p>Data Path Delayed Start. 111= Use for GSM 850 and GSM 900 bands. 011= Use for DCS 1800 and PCS 1900 bands (default). Note: Use the recommended setting for each band. Other settings reserved.</p> |
| 10 | XPD1 | <p>Reference Buffer Powerdown. 0 = Reference buffer automatically enabled (default). 1 = Reference buffer disabled. Note: This bit should be set to 0 during normal operation. To achieve lowest Si4201 powerdown current (I_{PDN1}), this bit should be set to 1. The XBUF bit in Register 12h must also be set appropriately.</p> |
| 9 | Reserved | Program to one. |
| 8 | XSEL | <p>Reference Frequency Select. 0 = No divider. XIN = 13 MHz (default). 1 = Divide XIN by 2. XIN = 26 MHz. Note: The internal clock should always be 13 MHz.</p> |
| 7 | Reserved | Program to zero. |
| 6 | Reserved | Program to one. |
| 5 | Reserved | Program to zero. |
| 4 | Reserved | Program to one. |
| 3:1 | Reserved | Program to zero. |
| 0 | CSEL | <p>Digital IIR Coefficient Select. 0 = High selectivity filter (default). 1 = Low selectivity filter.</p> |

Register 12h. DAC Configuration (Si4201)

| Bit | D17 | D16 | D15 | D14 | D13 | D12 | D11 | D10 | D9 | D8 | D7 | D6 | D5 | D4 | D3 | D2 | D1 | D0 |
|------|-----|-----|-----|-----|-----|-----|-----|-----|------|----|------|--------------|----|----|------------|----|------------|----|
| Name | 0 | 0 | 0 | 0 | 0 | 0 | 0 | 1 | XBUF | 0 | ZDBS | ZERODEL[2:0] | | | DACCM[1:0] | | DACFS[1:0] | |

| Bit | Name | Function | | | | | | | | | | | | | | | | | | | | | | | | | | | | | | | | | | | | |
|-------|--------------|---|-----------|-----|---------|--|------|------------|-------------|-----------|------|-------------|-------------|--|------|-------------|-------------|--|------|-------------|-------------|--|------|-------------|-------------|--|------|-------------|-------------|--|------|-------------|-------------|--|------|----------|--|--|
| 17:11 | Reserved | Program to zero. | | | | | | | | | | | | | | | | | | | | | | | | | | | | | | | | | | | | |
| 10 | Reserved | Program to one. | | | | | | | | | | | | | | | | | | | | | | | | | | | | | | | | | | | | |
| 9 | XBUF | <p>Reference Buffer Power Control. 0 = Reference buffer disabled. 1 = Reference buffer automatically enabled (default). Note: This bit should be set to 1 during normal operation. To achieve the lowest Si4201 power down current (I_{PDN1}), this bit should be set to 0. The XPD1 bit in Register 11h must also be set appropriately.</p> | | | | | | | | | | | | | | | | | | | | | | | | | | | | | | | | | | | | |
| 8 | Reserved | Program to zero. | | | | | | | | | | | | | | | | | | | | | | | | | | | | | | | | | | | | |
| 7 | ZDBS | <p>ZERODEL Band Select. 0 = Use ZERODEL[2:0] settings corresponding to DCS/PCS column (default). 1 = Use RXBAND[1:0] to determine ZERODEL[2:0] delay setting (GSM or DCS/PCS).</p> | | | | | | | | | | | | | | | | | | | | | | | | | | | | | | | | | | | | |
| 6:4 | ZERODEL[2:0] | <p>RX Output Zero Delay.</p> <table border="1"> <thead> <tr> <th>Code</th> <th>GSM</th> <th>DCS/PCS</th> <th></th> </tr> </thead> <tbody> <tr> <td>000:</td> <td>90 μs</td> <td>130 μs</td> <td>(Default)</td> </tr> <tr> <td>001:</td> <td>110 μs</td> <td>150 μs</td> <td></td> </tr> <tr> <td>010:</td> <td>130 μs</td> <td>170 μs</td> <td></td> </tr> <tr> <td>011:</td> <td>140 μs</td> <td>180 μs</td> <td></td> </tr> <tr> <td>100:</td> <td>150 μs</td> <td>190 μs</td> <td></td> </tr> <tr> <td>101:</td> <td>160 μs</td> <td>200 μs</td> <td></td> </tr> <tr> <td>110:</td> <td>180 μs</td> <td>220 μs</td> <td></td> </tr> <tr> <td>111:</td> <td colspan="3">Reserved</td> </tr> </tbody> </table> <p>Note: DAC input is forced to zero after \overline{PDN} is deasserted. This feature can be used for baseband ADC offset calibration. Offsets induced on channels due to 13 MHz harmonics are not included in the calibrated value.</p> | Code | GSM | DCS/PCS | | 000: | 90 μ s | 130 μ s | (Default) | 001: | 110 μ s | 150 μ s | | 010: | 130 μ s | 170 μ s | | 011: | 140 μ s | 180 μ s | | 100: | 150 μ s | 190 μ s | | 101: | 160 μ s | 200 μ s | | 110: | 180 μ s | 220 μ s | | 111: | Reserved | | |
| Code | GSM | DCS/PCS | | | | | | | | | | | | | | | | | | | | | | | | | | | | | | | | | | | | |
| 000: | 90 μ s | 130 μ s | (Default) | | | | | | | | | | | | | | | | | | | | | | | | | | | | | | | | | | | |
| 001: | 110 μ s | 150 μ s | | | | | | | | | | | | | | | | | | | | | | | | | | | | | | | | | | | | |
| 010: | 130 μ s | 170 μ s | | | | | | | | | | | | | | | | | | | | | | | | | | | | | | | | | | | | |
| 011: | 140 μ s | 180 μ s | | | | | | | | | | | | | | | | | | | | | | | | | | | | | | | | | | | | |
| 100: | 150 μ s | 190 μ s | | | | | | | | | | | | | | | | | | | | | | | | | | | | | | | | | | | | |
| 101: | 160 μ s | 200 μ s | | | | | | | | | | | | | | | | | | | | | | | | | | | | | | | | | | | | |
| 110: | 180 μ s | 220 μ s | | | | | | | | | | | | | | | | | | | | | | | | | | | | | | | | | | | | |
| 111: | Reserved | | | | | | | | | | | | | | | | | | | | | | | | | | | | | | | | | | | | | |
| 3:2 | DACCM[1:0] | <p>RX Output Common Mode Voltage. 00 = 1.0 V. 01 = 1.25 V (default). 10 = 1.35 V. 11 = Reserved.</p> | | | | | | | | | | | | | | | | | | | | | | | | | | | | | | | | | | | | |
| 1:0 | DACFS[1:0] | <p>RX Output Differential Full Scale Voltage. 00 = 1.0 V_{PPD}. 01 = 2.0 V_{PPD} (default). 10 = 3.5 V_{PPD}. 11 = Reserved.</p> | | | | | | | | | | | | | | | | | | | | | | | | | | | | | | | | | | | | |

Register 19h. Reserved (Si4201)

| Bit | D17 | D16 | D15 | D14 | D13 | D12 | D11 | D10 | D9 | D8 | D7 | D6 | D5 | D4 | D3 | D2 | D1 | D0 |
|------|-----|-----|-----|-----|-----|-----|-----|-----|----|----|----|----|----|----|----|----|----|----|
| Name | 0 | 0 | 0 | 0 | 0 | 0 | 0 | 0 | 0 | 0 | 0 | 0 | 0 | 0 | 0 | 0 | 0 | 0 |

| Bit | Name | Function |
|------|----------|------------------|
| 17:0 | Reserved | Program to zero. |

Register 20h. RX Master #1

| Bit | D17 | D16 | D15 | D14 | D13 | D12 | D11 | D10 | D9 | D8 | D7 | D6 | D5 | D4 | D3 | D2 | D1 | D0 |
|------|-------------|-----|-------------------------|-----|-----|-----|-----|-----|----|----|----|----|----|----|----|----|----|----|
| Name | RXBAND[1:0] | | N _{RF1} [15:0] | | | | | | | | | | | | | | | |

Notes:

1. See registers 03h and 33h for bit definitions.
2. When this register is written, the PDIB bit automatically sets to 0, the PDRB bit is set to 1, and the RFUP bit is set as a function of RXBAND[1:0].

Register 21h. RX Master #2

| Bit | D17 | D16 | D15 | D14 | D13 | D12 | D11 | D10 | D9 | D8 | D7 | D6 | D5 | D4 | D3 | D2 | D1 | D0 |
|------|-----|-----------|-----|-----------|-----|-----------|-----|------------|----|----|------------|----|----|----|----|----|----|----|
| Name | 0 | DPDS[2:0] | | LNAC[1:0] | | LNAG[1:0] | | AGAIN[2:0] | | 0 | DGAIN[5:0] | | | | | | | |

Note: See registers 05h and 11h for bit definitions.

Register 22h. RX Master #3

| Bit | D17 | D16 | D15 | D14 | D13 | D12 | D11 | D10 | D9 | D8 | D7 | D6 | D5 | D4 | D3 | D2 | D1 | D0 |
|------|-----|-----|-----|-----|-----|-----|-----|-----|----|----|----|----|------------|----|----|----|----|----|
| Name | 0 | 0 | 0 | 0 | 0 | 0 | 0 | 0 | 0 | 0 | 0 | 0 | DGAIN[5:0] | | | | | |

Notes:

1. See register 05h for bit definitions.
2. The DGAIN[5:0] in register 22h can be changed without powering down.

Register 23h. TX Master #1

| Bit | D17 | D16 | D15 | D14 | D13 | D12 | D11 | D10 | D9 | D8 | D7 | D6 | D5 | D4 | D3 | D2 | D1 | D0 |
|-------------|-------------|-----|-------------------------|-----|-----|-----|-----|-----|----|----|----|----|----|----|----|----|----|----|
| Name | TXBAND[1:0] | | N _{RF2} [15:0] | | | | | | | | | | | | | | | |

Notes:

1. See registers 03h and 34h for bit definitions.
2. When this register is written, the PDIB bit automatically sets to 1, and the PDRB bit is set to 1.

Register 24h. TX Master #2

| Bit | D17 | D16 | D15 | D14 | D13 | D12 | D11 | D10 | D9 | D8 | D7 | D6 | D5 | D4 | D3 | D2 | D1 | D0 |
|-------------|----------|-----|-----|-----|------------------------|-----|-----|-----|----|----|----|----|----|----|----|----|----|----|
| Name | FIF[3:0] | | | | N _{IF} [13:0] | | | | | | | | | | | | | |

Note: See registers 04h and 35h for bit definitions.

Register 30h. Revision/Read (Si4133T)

| Bit | D17 | D16 | D15 | D14 | D13 | D12 | D11 | D10 | D9 | D8 | D7 | D6 | D5 | D4 | D3 | D2 | D1 | D0 |
|-------------|-----|-----|-----|-----|-----|-----|-----|-----|----|----|-----------|----|----|----|----|----|----|----|
| Name | 0 | 0 | 0 | 0 | 0 | 0 | 0 | 0 | 0 | 0 | REV3[7:0] | | | | | | | |

| Bit | Name | Function |
|------|-----------|--|
| 17:8 | Reserved | Read as zero. |
| 7:0 | REV3[7:0] | Si4133T Revision (read only). 80h = Rev A. 81h = Rev B. 82h = Rev C (latest revision). |

Note: Registers on the Si4133T can be read by writing this register with the address of the register to be read.

Register 31h. Main Configuration (Si4133T)

| Bit | D17 | D16 | D15 | D14 | D13 | D12 | D11 | D10 | D9 | D8 | D7 | D6 | D5 | D4 | D3 | D2 | D1 | D0 | |
|------|-----|-----|-----|-------------|-----|-----|-----|-----|----|----|----|----|----|----|------|------|----|----|---|
| Name | 0 | 0 | 0 | SDOSEL[3:0] | | | | 0 | 0 | 0 | 0 | 0 | 0 | 0 | RFUP | DIV2 | 0 | 0 | 1 |

| Bit | Name | Function |
|-------|-------------|--|
| 17:15 | Reserved | Program to zero. |
| 14:11 | SDOSEL[3:0] | <p>SDO Output Control Register. The mux_output table is as follows: 0000 Connected to the Output Shift Register (default). 0001 Force the Output to Low. 0010 Reference Clock. 0011 Lock Detect (LDET_B) Signal from Phase Detectors. 1111 High Impedance.</p> <p>Notes:</p> <ol style="list-style-type: none"> SDO is high-impedance when $\overline{\text{PDN}} = 0$. SDO is Serial Data Output when in register read mode. |
| 10:5 | Reserved | Program to zero. |
| 4 | RFUP | <p>RF PLL Update Rate (RF1 VCO only). 0 = 200 kHz update rate (Receive GSM modes). 1 = 100 kHz update rate (Receive DCS and PCS modes). Note: This bit is set to 1 when register 20h D[17:16] = 01_b or 10_b (DCS 1800 or PCS 1900 receive modes) and is set to 0 when D[17:16] = 00_b or 11_b (GSM 850 or GSM 900 modes).</p> |
| 3 | DIV2 | <p>Input Clock Frequency. 0 = No divider. XIN = 13 MHz. 1 = Divide XIN by 2. XIN = 26 MHz.</p> |
| 2:1 | Reserved | Program to zero. |
| 0 | Reserved | Program to one. |

Register 32h. Powerdown (Si4133T)

| Bit | D17 | D16 | D15 | D14 | D13 | D12 | D11 | D10 | D9 | D8 | D7 | D6 | D5 | D4 | D3 | D2 | D1 | D0 |
|------|-----|-----|-----|-----|-----|-----|-----|-----|----|----|----|----|----|----|----|----|------|------|
| Name | 0 | 0 | 0 | 0 | 0 | 0 | 0 | 0 | 0 | 0 | 0 | 0 | 0 | 0 | 0 | 0 | PDIB | PDRB |

| Bit | Name | Function |
|------|----------|---|
| 17:2 | Reserved | Program to zero. |
| 1 | PDIB | Powerdown IF PLL. 0 = IF synthesizer powered down. 1 = IF synthesizer powered up when the $\overline{\text{PDN}}$ pin is high. Notes: <ol style="list-style-type: none"> The IF PLL is only used in transmit mode. Powerdown for receive mode. This bit is set to 0 when register 20h is written (Receive mode). This bit is set to 1 when register 23h is written (Transmit mode). |
| 0 | PDRB | Powerdown RF PLL. 0 = RF synthesizer powered down. 1 = RF synthesizer powered up when the $\overline{\text{PDN}}$ pin is high. Notes: <ol style="list-style-type: none"> This bit is set to 1 when register 20h is written (Receive mode). This bit is set to 1 when register 23h is written (Transmit mode). |

Register 33h. RF1 N Divider (Si4133T)

| Bit | D17 | D16 | D15 | D14 | D13 | D12 | D11 | D10 | D9 | D8 | D7 | D6 | D5 | D4 | D3 | D2 | D1 | D0 |
|------|-----|-----|------------------------|-----|-----|-----|-----|-----|----|----|----|----|----|----|----|----|----|----|
| Name | 0 | 0 | $N_{\text{RF1}}[15:0]$ | | | | | | | | | | | | | | | |

| Bit | Name | Function |
|-------|------------------------|--|
| 17:16 | Reserved | Program to zero. |
| 15:0 | $N_{\text{RF1}}[15:0]$ | N Divider for RF PLL (RF1 VCO). Used for Receive mode. |

Register 34h. RF2 N Divider (Si4133T)

| Bit | D17 | D16 | D15 | D14 | D13 | D12 | D11 | D10 | D9 | D8 | D7 | D6 | D5 | D4 | D3 | D2 | D1 | D0 |
|------|-----|-----|------------------------|-----|-----|-----|-----|-----|----|----|----|----|----|----|----|----|----|----|
| Name | 0 | 0 | $N_{\text{RF2}}[15:0]$ | | | | | | | | | | | | | | | |

| Bit | Name | Function |
|-------|------------------------|---|
| 17:16 | Reserved | Program to zero. |
| 15:0 | $N_{\text{RF2}}[15:0]$ | N Divider for RF PLL (RF2 VCO). Used for Transmit mode. |

Register 35h. IF N Divider (Si4133T)

| Bit | D17 | D16 | D15 | D14 | D13 | D12 | D11 | D10 | D9 | D8 | D7 | D6 | D5 | D4 | D3 | D2 | D1 | D0 |
|------|-----|-----|------------------------|-----|-----|-----|-----|-----|----|----|----|----|----|----|----|----|----|----|
| Name | 0 | 0 | N _{IF} [15:0] | | | | | | | | | | | | | | | |

| Bit | Name | Function |
|-------|------------------------|---|
| 17:16 | Reserved | Program to zero. |
| 15:0 | N _{IF} [15:0] | N Divider for IF Synthesizer. Used for transmit mode. |

Register 3Ah. Reserved (Si4133T)

| Bit | D17 | D16 | D15 | D14 | D13 | D12 | D11 | D10 | D9 | D8 | D7 | D6 | D5 | D4 | D3 | D2 | D1 | D0 |
|------|-----|-----|-----|-----|-----|-----|-----|-----|----|----|----|----|----|----|----|----|----|----|
| Name | 0 | 0 | 0 | 0 | 0 | 0 | 0 | 0 | 0 | 0 | 0 | 0 | 0 | 0 | 1 | 0 | 0 | 1 |

| Bit | Name | Function |
|------|----------|------------------|
| 17:4 | Reserved | Program to zero. |
| 3 | Reserved | Program to one. |
| 2:1 | Reserved | Program to zero. |
| 0 | Reserved | Program to one. |

Register 3Eh. Reserved (Si4133T)

| Bit | D17 | D16 | D15 | D14 | D13 | D12 | D11 | D10 | D9 | D8 | D7 | D6 | D5 | D4 | D3 | D2 | D1 | D0 |
|------|-----|-----|-----|-----|-----|-----|-----|-----|----|----|----|----|----|----|----|----|----|----|
| Name | 0 | 0 | 0 | 0 | 0 | 0 | 0 | 0 | 0 | 0 | 0 | 0 | 0 | 0 | 1 | 1 | 1 | 1 |

| Bit | Name | Function |
|------|----------|------------------|
| 17:4 | Reserved | Program to zero. |
| 3:0 | Reserved | Program to one. |

Register 3Fh. Reserved (Si4133T)

| Bit | D17 | D16 | D15 | D14 | D13 | D12 | D11 | D10 | D9 | D8 | D7 | D6 | D5 | D4 | D3 | D2 | D1 | D0 |
|------|-----|-----|-----|-----|-----|-----|-----|-----|----|----|----|----|----|----|----|----|----|----|
| Name | 0 | 0 | 0 | 0 | 0 | 0 | 0 | 0 | 0 | 0 | 0 | 0 | 0 | 1 | 0 | 0 | 0 | 0 |

| Bit | Name | Function |
|------|----------|------------------|
| 17:5 | Reserved | Program to zero. |
| 4 | Reserved | Program to one. |
| 3:0 | Reserved | Program to zero. |

6. Pin Descriptions: Si4200-G-GM

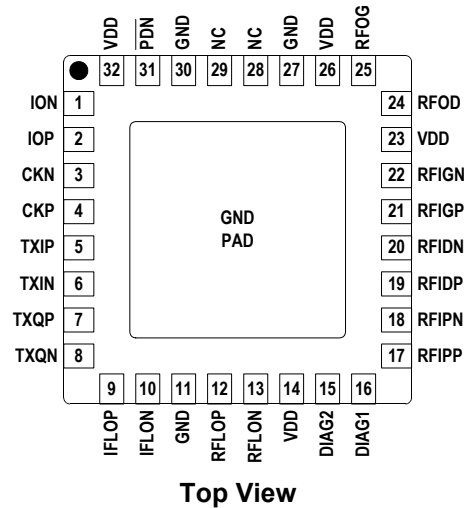

| Pin Number(s) | Name | Description |
|---------------------|--------------|---|
| 1, 2 | ION, IOP | Data output to Si4201 (differential). |
| 3, 4 | CKN, CKP | Clock input from Si4201 (differential). |
| 5, 6 | TXIP, TXIN | Transmit I input (differential). |
| 7, 8 | TXQP, TXQN | Transmit Q input (differential). |
| 9, 10 | IFLOP, IFLON | IFLO Input from Si4133T (differential). |
| 11, 27, 30, GND pad | GND | Ground. Connect to ground plane on PCB. |
| 12, 13 | RFLOP, RFLON | RFLO Input from Si4133T (differential). |
| 14, 23, 26, 32 | VDD | Supply voltage. |
| 15, 16 | DIAG2, DIAG1 | Diagnostic output. Can be used as digital outputs to control antenna switch functions. |
| 17, 18 | RFIPP, RFIPN | PCS LNA input (differential). Use for PCS 1900 band. |
| 19, 20 | RFIDP, RFIDN | DCS LNA input (differential). Use for DCS 1800 band. |
| 21, 22 | RFIGP, RFIGN | GSM LNA input (differential). Used for GSM 850 or E-GSM 900 bands. |
| 24 | RFOD | DCS and PCS transmit output to power amplifier. Used for DCS 1800 and PCS 1900 bands. |
| 25 | RFOG | GSM transmit output to power amplifier. Used for GSM 850 and E-GSM 900 bands. |
| 28, 29 | NC | These pins should be left disconnected. |
| 31 | PDN | Powerdown input (active low). |

7. Pin Descriptions: Si4200DB-BM

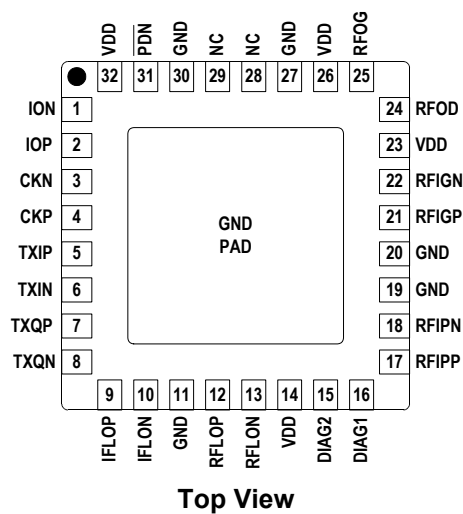

| Pin Number(s) | Name | Description |
|-----------------------------|--------------|---|
| 1, 2 | ION, IOP | Data output to Si4201 (differential). |
| 3, 4 | CKN, CKP | Clock input from Si4201 (differential). |
| 5, 6 | TXIP, TXIN | Transmit I input (differential). |
| 7, 8 | TXQP, TXQN | Transmit Q input (differential). |
| 9, 10 | IFLOP, IFLON | IFLO Input from Si4133T (differential). |
| 11, 19, 20, 27, 30, GND pad | GND | Ground. Connect to ground plane on PCB. |
| 12, 13 | RFLOP, RFLON | RFLO Input from Si4133T (differential). |
| 14, 23, 26, 32 | VDD | Supply voltage. |
| 15, 16 | DIAG2, DIAG1 | Diagnostic output. Can be used as digital outputs to control antenna switch functions. |
| 17, 18 | RFIPP, RFIPN | PCS LNA input (differential). Use for DCS 1800 or PCS 1900 bands. |
| 21, 22 | RFIGP, RFIGN | GSM LNA input (differential). Used for GSM 850 or E-GSM 900 bands. |
| 24 | RFOD | DCS and PCS transmit output to power amplifier. Used for DCS 1800 and PCS 1900 bands. |
| 25 | RFOG | GSM transmit output to power amplifier. Used for GSM 850 and E-GSM 900 bands. |
| 28, 29 | NC | These pins should be left disconnected. |
| 31 | PDN | Powerdown input (active low). |

8. Pin Descriptions: Si4201-BM

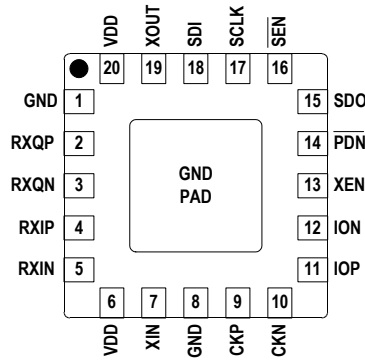

Top View

| Pin Number(s) | Name | Description |
|------------------|------------|--|
| 1, 8, GND pad | GND | Ground. Connect to ground plane on PCB. |
| 2, 3 | RXQP, RXQN | Receive Q output (differential). |
| 4, 5 | RXIP, RXIN | Receive I output (differential). |
| 6, 20 | VDD | Supply voltage. |
| 7 | XIN | Reference frequency input from crystal oscillator. |
| 9, 10 | CKP, CKN | Clock output to Si4200 (differential). |
| 11, 12 | IOP, ION | Data input from Si4200 (differential). |
| 13 | XEN | XOUT pin enable |
| 14 | PDN | Powerdown input (active low). |
| 15 | SDO | Serial data output. |
| 16 | SEN | Serial enable input (active low). |
| 17 | SCLK | Serial clock input. |
| 18 | SDI | Serial data input. |
| 19 | XOUT | Clock output to baseband. |

9. Pin Descriptions: Si4133T-BM

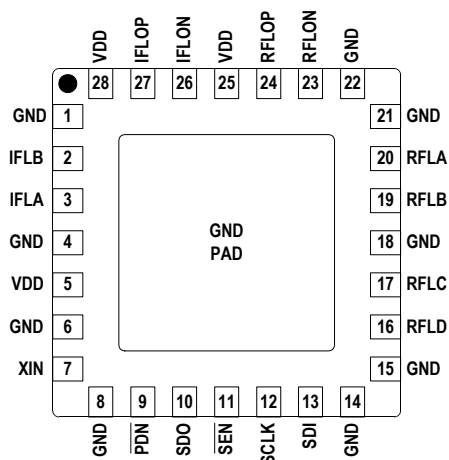

Top View

| Pin Number(s) | Name | Description |
|---|--------------|--|
| 1, 4, 6, 8, 14, 15, 18, 21, 22, GND pad | GND | Ground. Connect to ground plane on PCB. |
| 2, 3 | IFLB, IFLA | Tuning inductor connection for IF VCO. |
| 5, 25, 28 | VDD | Supply voltage. |
| 7 | XIN | Reference frequency input from crystal oscillator. |
| 9 | PDN | Powerdown input (active low). |
| 10 | SDO | Serial data output. |
| 11 | SEN | Serial enable input (active low). |
| 12 | SCLK | Serial clock input. |
| 13 | SDI | Serial data input. |
| 16, 17 | RFLD, RFLC | Tuning inductor connection for RF2 VCO. |
| 19, 20 | RFLB, RFLA | Tuning inductor connection for RF1 VCO. |
| 23, 24 | RFLON, RFLOP | RF PLL output to Si4200 (differential). |
| 26, 27 | IFLOP, IFLOP | IF PLL output to Si4200 (differential). |

10. Ordering Guide

| Part Number | Description | Package Type | Operating Temperature |
|-------------|--|--------------|-----------------------|
| Si4200-G-GM | Tri-Band Transceiver GSM 850 or E-GSM 900, DCS 1800, PCS 1900 | QFN Pb-free* | -20 to 85 °C |
| Si4200DB-BM | Dual-Band Aero Transceiver GSM 850/PCS 1900 or E-GSM 900/DCS 1800 | QFN* | -20 to 85 °C |
| Si4200DB-GM | Dual-Band Aero Transceiver GSM 850/PCS 1900 or E-GSM 900/DCS 1800 | QFN Pb-free* | -20 to 85 °C |
| Si4201-BM | Universal Baseband Interface | QFN* | -20 to 85 °C |
| Si4201-GM | Universal Baseband Interface | QFN Pb-free* | -20 to 85 °C |
| Si4133T-BM | Dual RF Synthesizer | QFN* | -20 to 85 °C |
| Si4133T-GM | Dual RF Synthesizer | QFN Pb-free* | -20 to 85 °C |

***Note:** Add an "R" at the end of the device to denote tape and reel option; 2500 quantity per reel.

11. Package Outline: Si4200-G-GM and Si4200DB-BM

Figure 18 illustrates the package details for the Si4200-G-GM and the Si4200DB-BM. Table 11 lists the values for the dimensions shown in the illustration.

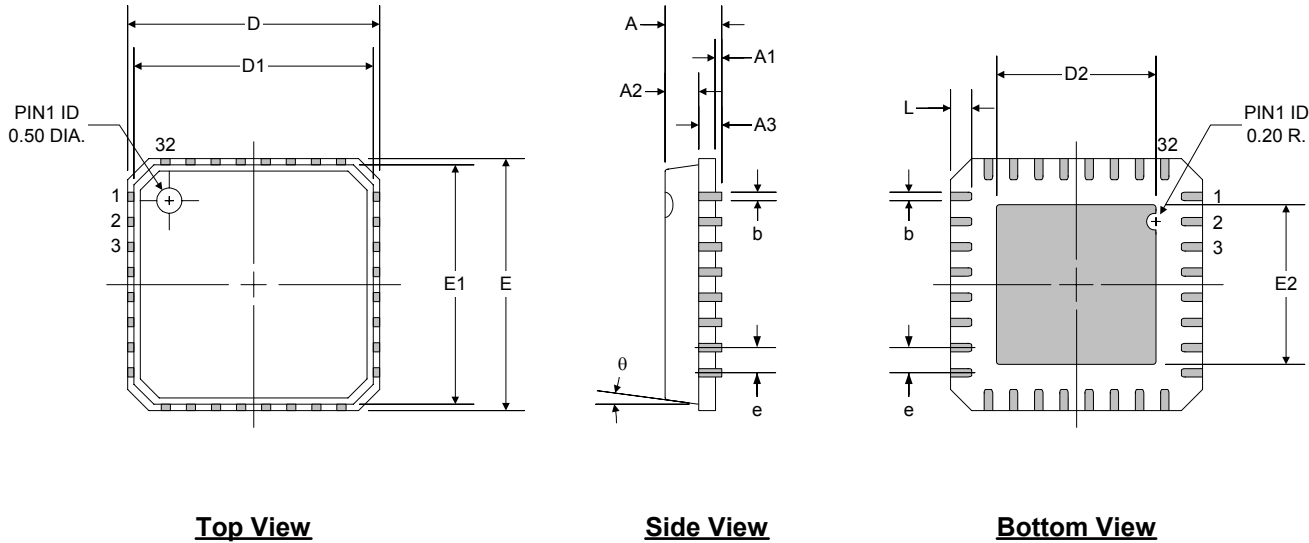

Figure 18. 32-Pin Quad Flat No-Lead Package (QFN)

Table 11. Package Dimensions

| Symbol | Millimeters | | |
|--------|-------------|------|------|
| | Min | Nom | Max |
| A | — | 0.85 | 0.90 |
| A1 | 0.00 | 0.01 | 0.05 |
| A2 | — | 0.65 | 0.70 |
| A3 | 0.20 REF. | | |
| b | 0.18 | 0.23 | 0.30 |
| D, E | 5.00 BSC | | |

| Symbol | Millimeters | | |
|----------|-------------|------|------|
| | Min | Nom | Max |
| D1, E1 | 4.75 BSC | | |
| D2, E2 | 3.15 | 3.30 | 3.45 |
| e | 0.50 BSC | | |
| θ | — | — | 12° |
| L | 0.30 | 0.40 | 0.50 |

Notes:

1. Dimensioning and tolerances conform to ASME Y14.5M. - 1994
2. Package warpage MAX 0.05 mm.
3. "b" applies to plated terminal and is measured between 0.20 and 0.25 mm from terminal TIP.
4. The package weight is approximately 68 mg.
5. The mold compound for this package has a flammability rating of UL94-V0 with an oxygen index of 28 minimum/54 typical.
6. The recommended reflow profile for this package is defined by the JEDEC-020B Small Body specification.

12. Package Outline: Si4201-BM

Figure 19 illustrates the package details for the Si4201-BM. Table 12 lists the values for the dimensions shown in the illustration.

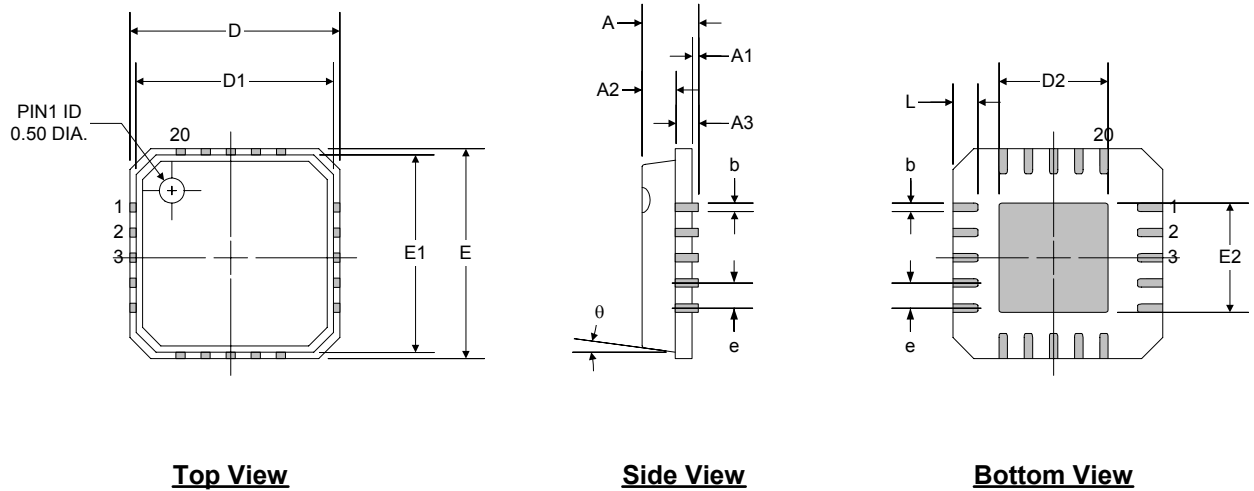

Figure 19. 20-pin Quad Flat No-Lead Package (QFN)

Table 12. Package Dimensions

| Symbol | Millimeters | | |
|--------|-------------|------|------|
| | Min | Nom | Max |
| A | — | 0.85 | 0.90 |
| A1 | 0.00 | 0.01 | 0.05 |
| A2 | — | 0.65 | 0.70 |
| A3 | 0.20 REF. | | |
| b | 0.18 | 0.23 | 0.30 |
| D, E | 4.00 BSC | | |

| Symbol | Millimeters | | |
|----------|-------------|------|------|
| | Min | Nom | Max |
| D1, E1 | 3.75 BSC | | |
| D2, E2 | 1.95 | 2.10 | 2.25 |
| e | 0.50 BSC | | |
| θ | — | — | 12° |
| L | 0.50 | 0.60 | 0.75 |

Notes:

1. Dimensioning and tolerances conform to ASME Y14.5M. - 1994
2. Package warpage MAX 0.05 mm.
3. "b" applies to plated terminal and is measured between 0.20 and 0.25 mm from terminal TIP.
4. The package weight is approximately 42 mg.
5. The mold compound for this package has a flammability rating of UL94-V0 with an oxygen index of 28 minimum/54 typical.
6. The recommended reflow profile for this package is defined by the JEDEC-020B Small Body specification.

13. Package Outline: Si4133T-BM

Figure 20 illustrates the package details for the Si4133T-BM. Table 13 lists the values for the dimensions shown in the illustration.

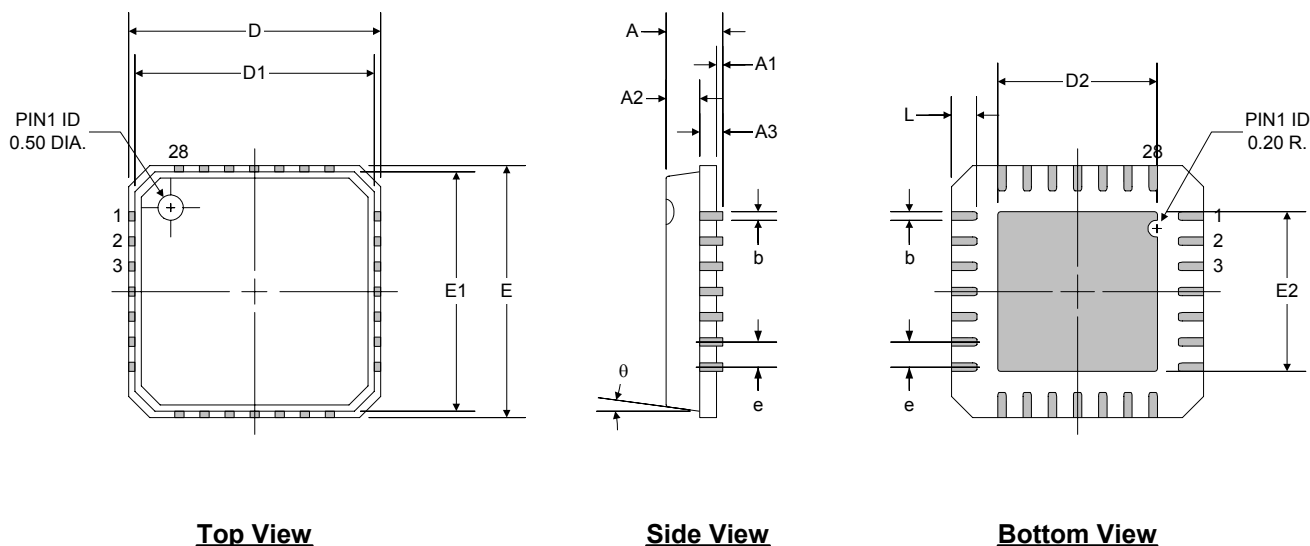

Figure 20. 28-Pin Quad Flat No-Lead Package (QFN)

Table 13. Package Dimensions

| Symbol | Millimeters | | |
|--------|-------------|------|------|
| | Min | Nom | Max |
| A | — | 0.85 | 0.90 |
| A1 | 0.00 | 0.01 | 0.05 |
| A2 | — | 0.65 | 0.70 |
| A3 | 0.20 REF. | | |
| b | 0.18 | 0.23 | 0.30 |
| D, E | 5.00 BSC | | |

| Symbol | Millimeters | | |
|----------|-------------|------|------|
| | Min | Nom | Max |
| D1, E1 | 4.75 BSC | | |
| D2, E2 | 2.55 | 2.70 | 2.85 |
| e | 0.50 BSC | | |
| θ | — | — | 12° |
| L | 0.50 | 0.60 | 0.75 |

Notes:

1. Dimensioning and tolerances conform to ASME Y14.5M. - 1994
2. Package warpage MAX 0.05 mm.
3. "b" applies to plated terminal and is measured between 0.20 and 0.25 mm from terminal TIP.
4. Package weight is approximately 66 mg.
5. The mold compound for this package has a flammability rating of UL94-V0 with an oxygen index of 28 minimum/54 typical.
6. The recommended reflow profile for this package is defined by the JEDEC-020B Small Body specification.

DOCUMENT CHANGE LIST

Revision 1.2 to Revision 1.3

- This document corresponds to the following:
 - Si4200DB revision E (dual band LNA) and Si4200 revision F (triple band LNA)
 - Si4201 revision C
 - Si4133T revisions B and C
- "10. Ordering Guide" on page 44 updated to include lead-free ordering option.
- "11. Package Outline: Si4200-G-GM and Si4200DB-BM" on page 45
 - Updated D2,E2 dimensions.
 - Updated device weight.
 - Added notes 5 and 6.
- "12. Package Outline: Si4201-BM" on page 46
 - Updated L dimension.
 - Updated device weight.
 - Added notes 5 and 6.
- "13. Package Outline: Si4133T-BM" on page 47
 - Updated D2,E2 dimensions.
 - Updated device weight.
 - Added notes 5 and 6.

Revision 1.3 to Revision 1.4

- Updated "10. Ordering Guide" on page 44 to include the Si4200-G-GM.

NOTES:

CONTACT INFORMATION

Silicon Laboratories Inc.

400 West Cesar Chavez
Austin, Texas 78701
Tel: 1+ (512) 416-8500
Fax: 1+ (512) 416-9669
Toll Free: 1+ (877) 444-3032
Email: Aeroinfo@silabs.com
Internet: www.silabs.com

The information in this document is believed to be accurate in all respects at the time of publication but is subject to change without notice. Silicon Laboratories assumes no responsibility for errors and omissions, and disclaims responsibility for any consequences resulting from the use of information included herein. Additionally, Silicon Laboratories assumes no responsibility for the functioning of undescribed features or parameters. Silicon Laboratories reserves the right to make changes without further notice. Silicon Laboratories makes no warranty, representation or guarantee regarding the suitability of its products for any particular purpose, nor does Silicon Laboratories assume any liability arising out of the application or use of any product or circuit, and specifically disclaims any and all liability, including without limitation consequential or incidental damages. Silicon Laboratories products are not designed, intended, or authorized for use in applications intended to support or sustain life, or for any other application in which the failure of the Silicon Laboratories product could create a situation where personal injury or death may occur. Should Buyer purchase or use Silicon Laboratories products for any such unintended or unauthorized application, Buyer shall indemnify and hold Silicon Laboratories harmless against all claims and damages.

Silicon Laboratories, Silicon Labs, and Aero are trademarks of Silicon Laboratories Inc.
Other products or brand names mentioned herein are trademarks or registered trademarks of their respective holder