

**STRAIGHT PLUG SOLDER TYPE
WITHOUT CONTACT - CABLE .141**

R125.054.000

Series : SMA

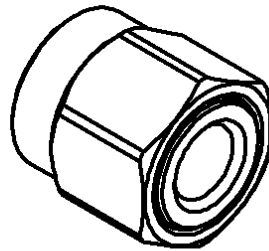
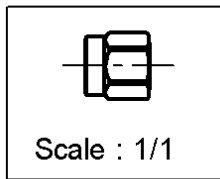
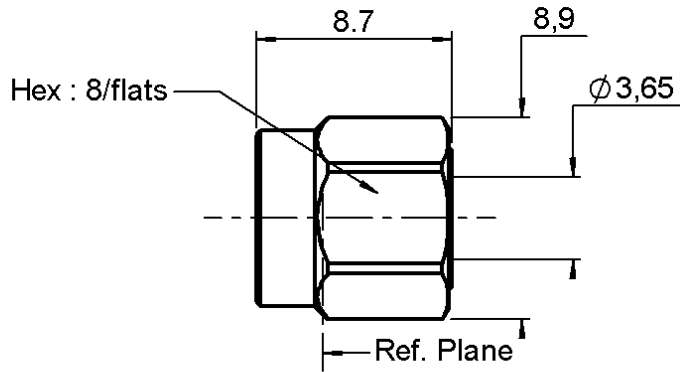

CECC 22111-801-01

All dimensions are in mm.



COMPONENTS	MATERIALS	PLATINGS (µm)
BODY	STAINLESS STEEL	GOLD 0.5 OVER NICKEL 2
CENTER CONTACT	-	-
OUTER CONTACT	-	-
INSULATOR	-	-
GASKET	SILICONE RUBBER	-
OTHERS PARTS	STAINLESS STEEL	GOLD 0.5 OVER NICKEL 2
-	-	-
-	-	-

Issue :0538 C

In the effort to improve our products, we reserve the right to make changes judged to be necessary.



**STRAIGHT PLUG SOLDER TYPE
WITHOUT CONTACT - CABLE .141**

R125.054.000

Series : SMA

PACKAGING

Standard	Unit	Other
100	'W' option	Contact us

SPECIFICATION

ELECTRICAL CHARACTERISTICS

Impedance		50 Ω
Frequency		0-18 GHz
VSWR	1.05 +	0.008 x F(GHz) Maxi
Insertion loss		0.03 √F(GHz) dB Maxi
RF leakage	- (90 - F(GHz)) dB Maxi
Voltage rating		500 Veff Maxi
Dielectric withstanding voltage		1000 Veff mini
Insulation resistance		5000 MΩ mini

CABLE ASSEMBLY

Stripping	a	b	c	d	e	f
mm	2.16	0.00	0.00	0.00	0.00	0.00

Assembly instruction :

Recommended cable(s)
RG 402
KS 2

Cable retention

- pull off **270** N mini
- torque **NA** N.cm

MECHANICAL CHARACTERISTICS

Center contact retention		
Axial force – Mating end	NA	N mini
Axial force – Opposite end	NA	N mini
Torque	NA	N.cm mini

Recommended torque		
Mating	100	N.cm
Panel nut	NA	N.cm
Clamp nut	NA	N.cm
A/F clamp nut	0.000	mm

Mating life	500	Cycles mini
Weight	2.051	g

TOOLING

Part Number	Description	Hexagon
.	.	.
R282.120.010	SMA TOOLBOX	
R282.053.100		
R282.059.100		
R282.066.100		
R282.200.000		
R282.740.000	SOLDERING MOUNTING	
R282.744.100		
R282.760.000	SMA RETAINING RING INSERT TOOL	

ENVIRONMENTAL

Operating temperature	-65/+105	° C
Hermetic seal	NA	Atm.cm3/s
Panel leakage	NA	

OTHERS CHARACTERISTICS

Issue :0538 C

In the effort to improve our products, we reserve the right to make changes judged to be necessary.



**STRAIGHT PLUG SOLDER TYPE
WITHOUT CONTACT - CABLE .141**

R125.054.000

Series : SMA

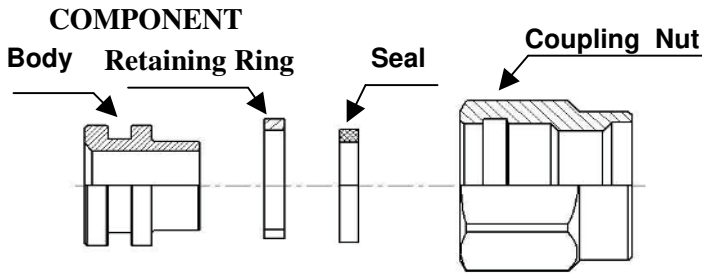

STRIPPING DIMENSIONS

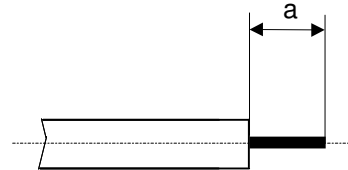

We recommend a thermal preconditioning cable.

1

Place the cable into the assembly jig (R282.740.000).
Place the connector body and positioner (R282.744.100) onto the cable and clamp cable.
Put 3 rings of solder around the cable.
Solder the body onto the cable.

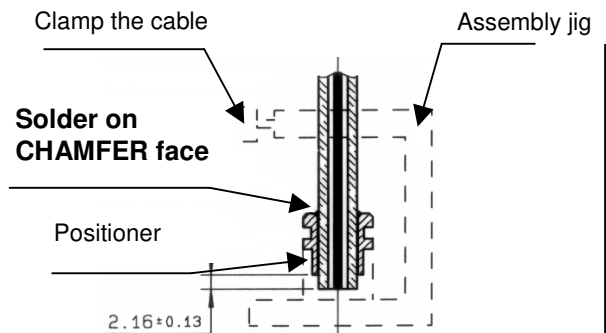

2

Immobilize the cable using the thumb crew on the cable holder (R282.059.100).
Get the positioner into the connector groove, using knurled push-button.
Push button until it stops.
Tighten cable.
Present the stripping tool (R282.053.100) opposite the cable holder.
Push and turn both elements with respect to each other.
When the tool stop cutting : pull off without turning it.
Present the trimmer (R282.066.100) opposite the cable holder, push and turn both elements with respect to each other until fully home.
Place retaining ring onto its insert tool (R282.760.000).
Push sub-assembly into the tool until the retaining ring snaps into place.
Place the interface seal O ring onto body.
Compress retaining ring using retaining ring pliers.
Push coupling nut onto sub-assembly and over retaining ring.

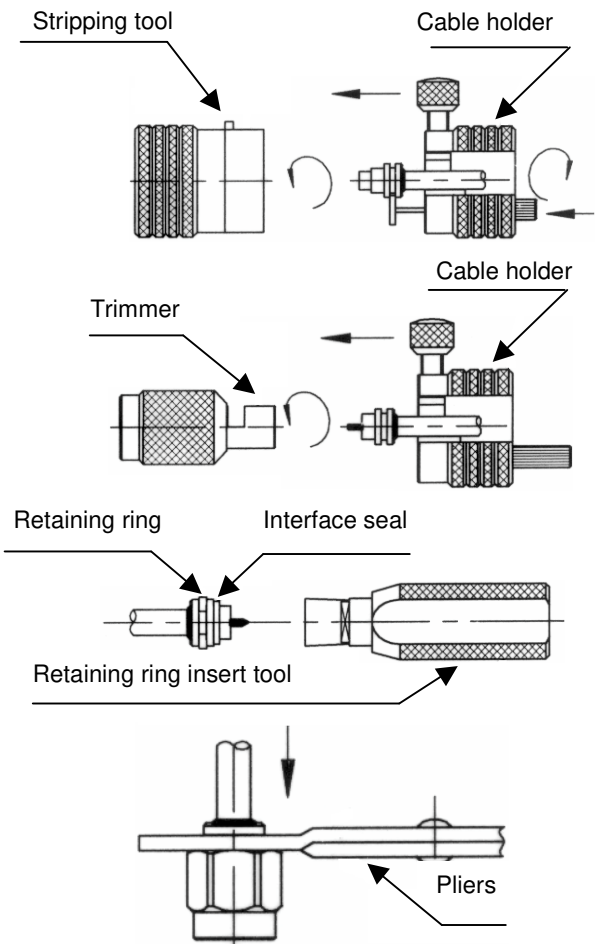

Issue :0538 C

In the effort to improve our products, we reserve the right to make changes judged to be necessary.

