

REVISIONS			
REV	DESCRIPTION, ECN, EAR NO.	DATE	APP'D
C	ADD NOTES FOR TYPE C	JUN13/22	L.CHAN
D	ADD DIMS OF TAB	JUN16/22	K.TANG

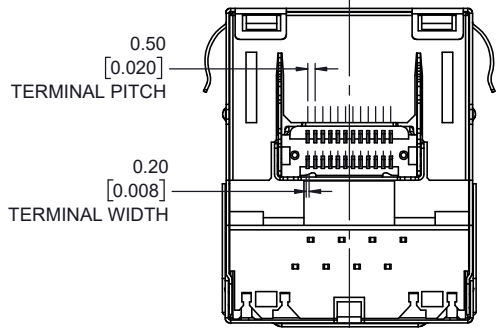
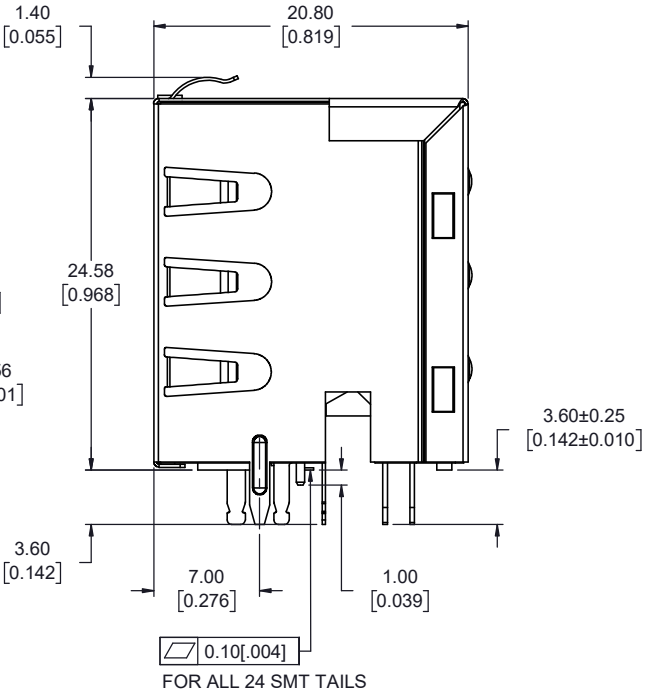
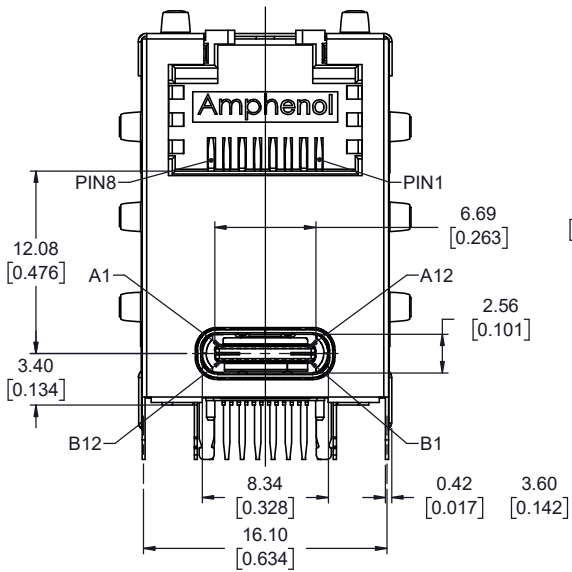
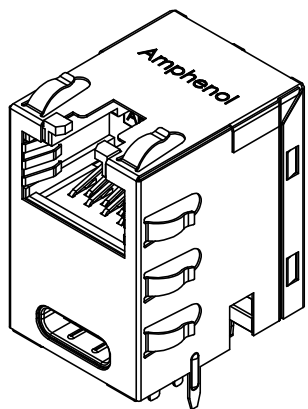
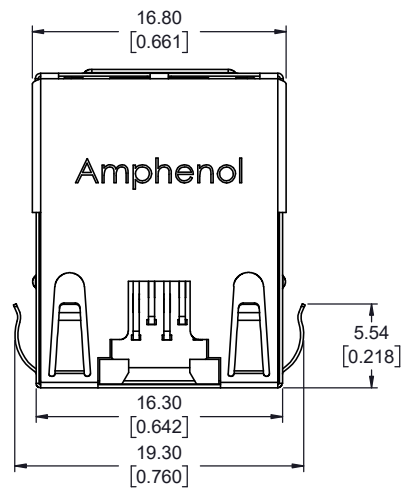

NOTES:

- 1. RJ45:
 - HOUSING: HIGH TEMPERATURE THERMOPLASTIC
FLAMMABILITY RATING UL 94V-0, COLOR: BLACK
 - CONTACTS: PHOSPHOR BRONZE,
PLATING: SELECTIVE GOLD PLATING ON THE MATING AREA, (SEE PART NO. FOR THICKNESS)
10µ" [2.54 MICRONS] MIN MATTE TIN ON THE TAILS,
50µ" [1.27 MICRONS] MIN. NICKEL UNDERPLATE
 - SHIELD: STAINLESS STEEL WITH TIN FINISHED PCB TAILS.

RJ45 PORT CAPABLE OF SUPPORTING 1000BASE-T or 2.5G BASE-T. CATEGORY 5e PERFORMANCE:

FREQUENCY MHZ	NEAR-END CROSS TALK dB, MIN.	RETURN LOSS dB, MIN.	INSERTION LOSS dB, MAX.
1.0	65	30	0.1
4.0	65	30	0.1
8.0	64.9	30	0.1
10.0	63	30	0.1
16.0	58.9	30	0.2
20.0	57	30	0.2
25.0	55	30	0.2
31.25	53.1	30	0.2
62.5	47.1	24.1	0.3
100.0	43	20	0.4

2. TYPE C

- HOUSING: HIGH TEMPERATURE THERMOPLASTIC
FLAMMABILITY RATING UL 94V-0, COLOR: BLACK
- CONTACTS: PHOSPHOR BRONZE
PLATING: 30µ" [0.76 MICRONS] MIN. GOLD OVER 50µ" [1.27 MICRONS] MIN. NICKEL ON THE MATING AREA WITH MATTE TIN OVER NICKEL ON THE TAILS.
- SHIELD: STAINLESS STEEL, 50µ" [1.27 MICRONS] MIN. NICKEL OVERALL.

THE TYPE C MEET THE PERFORMANCE OF TYP C 3.1 GEN2
AMPHENOL PART NUMBER: RJE4E-188-1X01

- GOLD PLATING OPTION
- 1= 6µ" GOLD PLATING
 - 2=15µ" GOLD PLATING
 - 3=30µ" GOLD PLATING
 - 4=50µ" GOLD PLATING



UNLESS SPECIFIED OTHERWISE	DRAWN JACK.GUO	JUL11/18
PRIMARY UNITS MILLIMETERS	CHECKED L.CHAN	JUL11/18
SECONDARY INCHES	M.E. APP'D	
REFERENCE IN PARENTHESES	Q.A. APP'D	
GENERAL TOLERANCES	DWG APPR.	
1 DECIMAL PLACE ±0.38	ENG. REL. NO.	
2 DECIMAL PLACES ±0.25	REF. EAR#: RJ18136	
3 DECIMAL PLACES ±0.13	THIRD ANGLE PROJECTION	
ANGULAR DEGREES ±1.0°	DO NOT SCALE DRAWING	

Amphenol Canada Corp.
Commercial Products

RJ45(CAT5e) OVER USB TYPE C MODULAR, JACK, 8P8C, SHIELDED WITH TOP AND SIDE TABS, WITHOUT LED, SUITABLE FOR REFLOW PROCESS, ESD TRAY PACKAGE - RoHS COMPLIANT

DWG. NO. P-RJE4E-188-1X01

CODE ID NO. 03554 DWG SIZE: X SCALE: 5:1 SHEET 1 OF 4

REVISIONS			
REV	DESCRIPTION, ECN, EAR NO.	DATE	APP'D
C	ADD NOTES FOR TYPE C	JUN13/22	L.CHAN
D	ADD DIMS OF TAB	JUN16/22	K.TANG

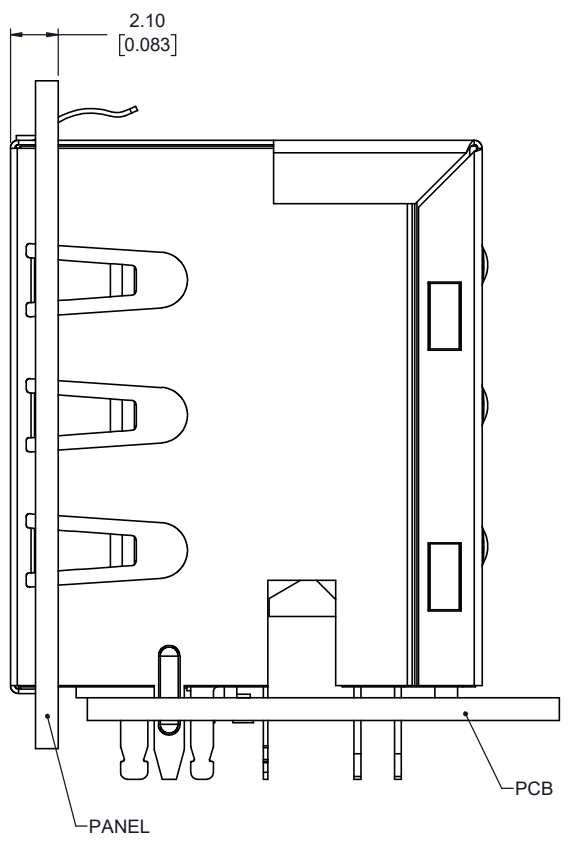
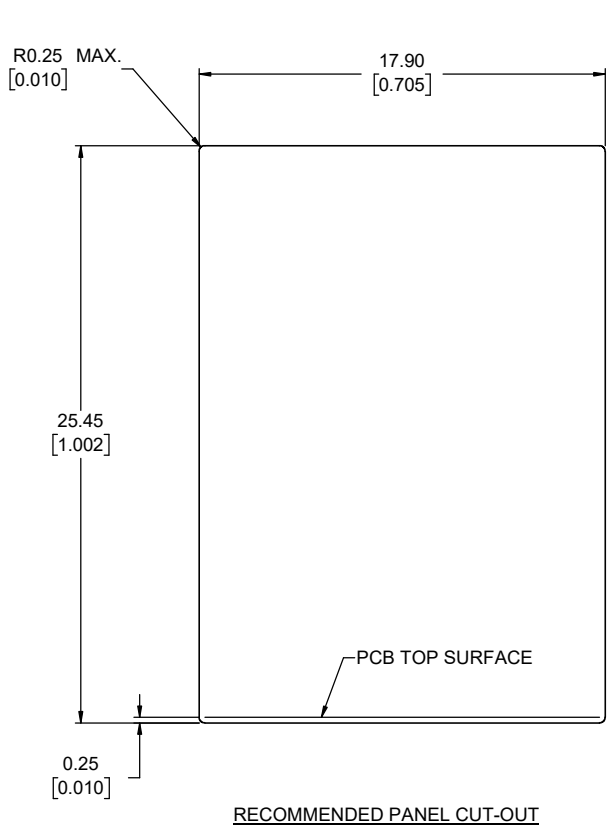

UNLESS SPECIFIED OTHERWISE	DRAWN	JACK.GUO	JUL11/18
PRIMARY UNITS MILLIMETERS	CHECKED	L.CHAN	JUL11/18
SECONDARY INCHES	M.E. APP'D		
REFERENCE IN PARENTHESES	Q.A. APP'D		
GENERAL TOLERANCES	DWG APPR.		
1 DECIMAL PLACE ±0.38	ENG. REL. NO.		
2 DECIMAL PLACES ±0.25	REF. EAR#: RJ18136		
3 DECIMAL PLACES ±0.13	THIRD ANGLE PROJECTION		
ANGULAR DEGREES ±1.0°	DO NOT SCALE DRAWING		

Amphenol Canada Corp.
Commercial Products

RJ45(CAT5e) OVER USB TYPE C MODULAR, JACK, 8P8C, SHIELDED WITH TOP AND SIDE TABS, WITHOUT LED, SUITABLE FOR REFLOW PROCESS, ESD TRAY PACKAGE - RoHS COMPLIANT

DWG. NO. **P-RJE4E-188-1X01** REV **D**

CODE ID NO. 03554 DWG SIZE: X SCALE: 6:1 SHEET 2 OF 4

THIS DOCUMENT CONTAINS PROPRIETARY INFORMATION AND SUCH INFORMATION MAY NOT BE DISCLOSED TO OTHERS FOR ANY PURPOSE OR USED FOR MANUFACTURING PURPOSES WITHOUT WRITTEN PERMISSION FROM AMPHENOL CANADA CORP.

REVISIONS			
REV	DESCRIPTION, ECN, EAR NO.	DATE	APP'D
C	ADD NOTES FOR TYPE C	JUN13/22	L.CHAN
D	ADD DIMS OF TAB	JUN16/22	K.TANG

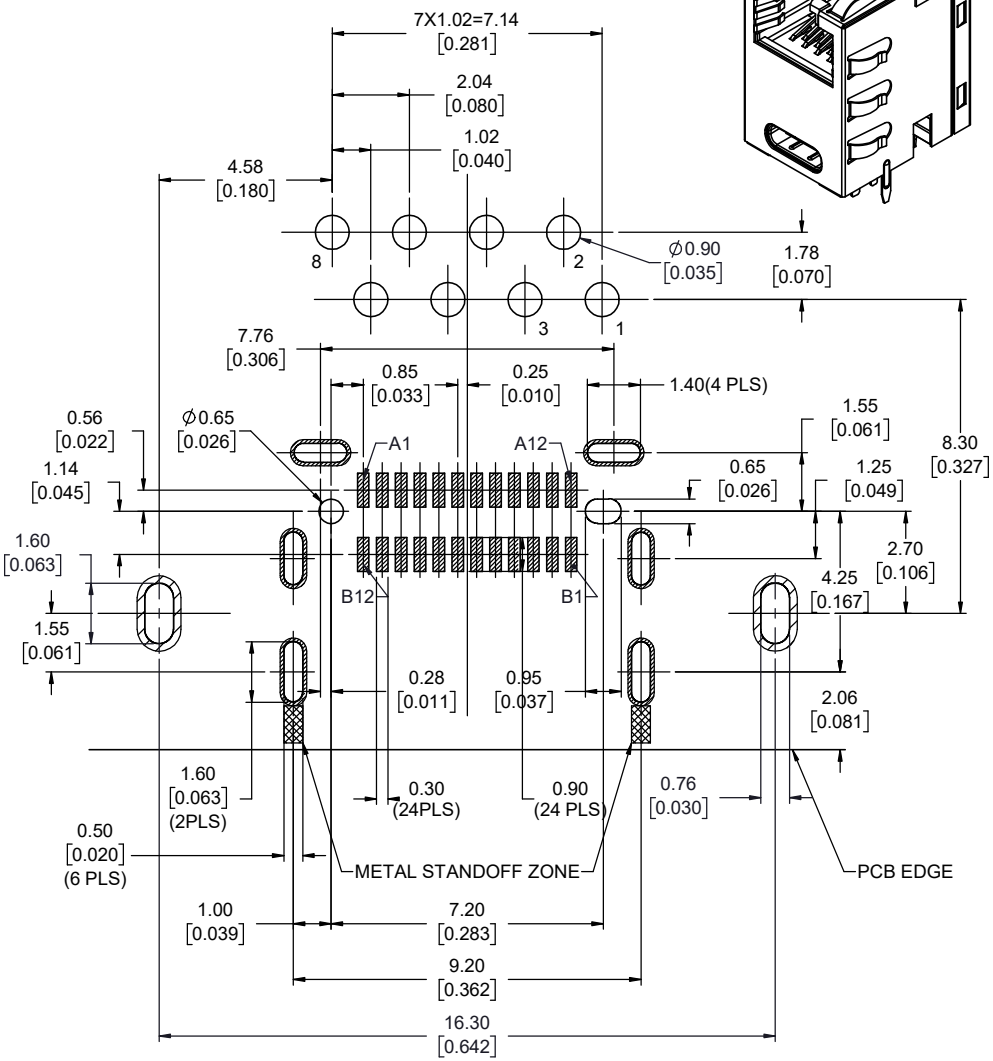
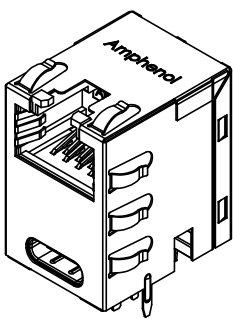

RECOMMENDED P.C.B LAYOUT 1
COMPONENT SIDE TO BOARD
TOLERANCE: ±0.05 [0.002]

RECOMMENDED P.C.B THICKNESS: 3.0MM
PAD RING WIDTH: 0.10MM

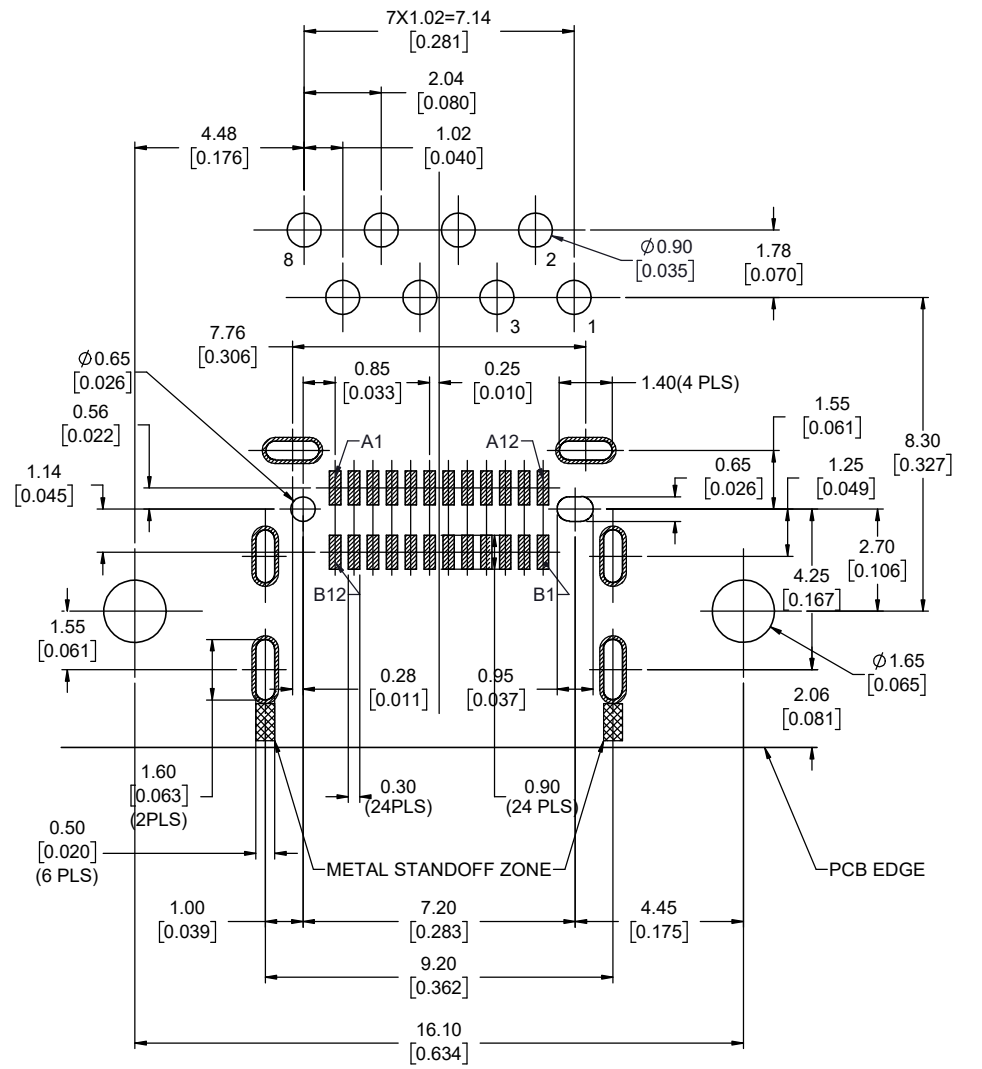

RECOMMENDED P.C.B LAYOUT 2
COMPONENT SIDE TO BOARD
TOLERANCE: ±0.05 [0.002]

RECOMMENDED P.C.B THICKNESS: 3.0MM
PAD RING WIDTH: 0.10MM

UNLESS SPECIFIED OTHERWISE	DRAWN	JACK.GUO	JUL11/18
PRIMARY UNITS MILLIMETERS	CHECKED	L.CHAN	JUL11/18
SECONDARY INCHES	M.E. APP'D		
REFERENCE IN PARENTHESES	Q.A. APP'D		
GENERAL TOLERANCES	DWG APPR.		
1 DECIMAL PLACE ±0.38	ENG. REL. NO.		
2 DECIMAL PLACES ±0.25	REF. EAR#:	RJ18136	
3 DECIMAL PLACES ±0.13	THIRD ANGLE PROJECTION		
ANGULAR DEGREES ±1.0°	DO NOT SCALE DRAWING		

Amphenol Canada Corp.
Commercial Products

RJ45(CAT5e) OVER USB TYPE C MODULAR, JACK, 8P8C, SHIELDED WITH TOP AND SIDE TABS, WITHOUT LED, SUITABLE FOR REFLOW PROCESS, ESD TRAY PACKAGE - RoHS COMPLIANT

DWG. NO. **P-RJE4E-188-1X01** REV **D**

CODE ID NO. 03554 DWG SIZE: X SCALE: 5:1 SHEET 3 OF 4

REVISIONS			
REV	DESCRIPTION, ECN, EAR NO.	DATE	APP'D
C	ADD NOTES FOR TYPE C	JUN13/22	L.CHAN
D	ADD DIMS OF TAB	JUN16/22	K.TANG

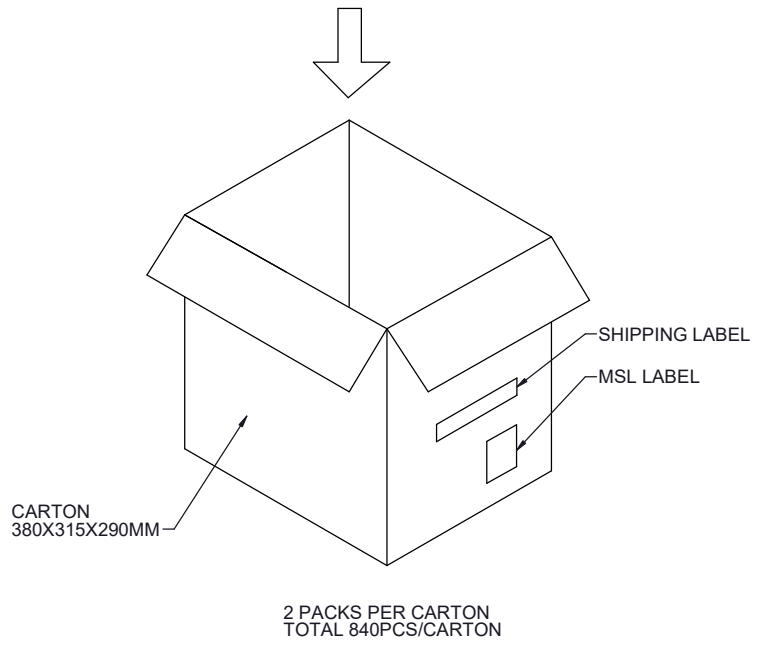
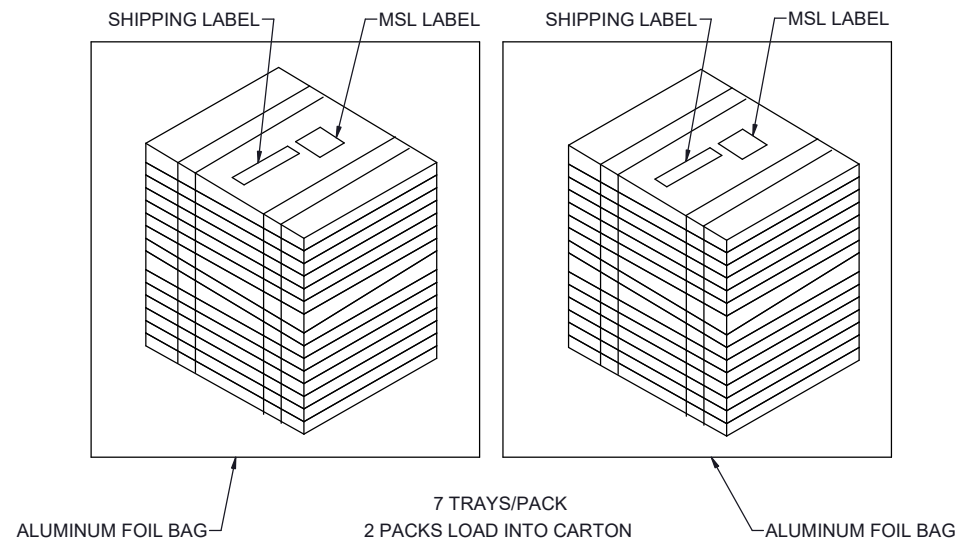
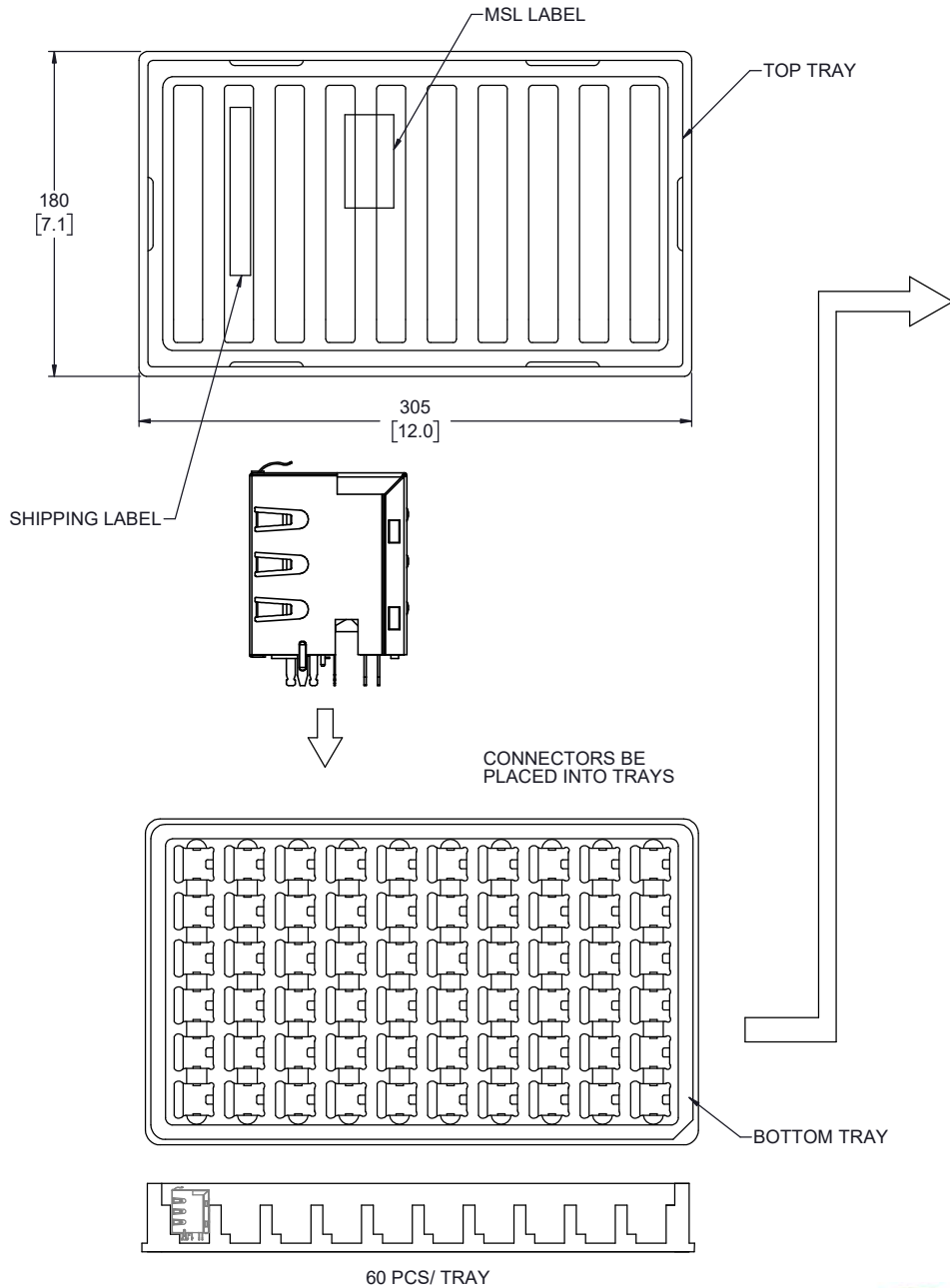

- NOTES:**
- PACKAGING QUANTITY:
- 60 PCS / TRAY
 - 7 TRAYS / PACK [420 PCS /PACK]
 - 2 PACKS / CARTON [14 TRAYS / CARTON]
 - 840 PCS / CARTON
 - THE PACKAGING IS MSL 2a COMPATIBLE.



UNLESS SPECIFIED OTHERWISE	DRAWN	JACK.GUO	JUL11/18
PRIMARY UNITS MILLIMETERS	CHECKED	L.CHAN	JUL11/18
SECONDARY INCHES	M.E. APP'D		
REFERENCE IN PARENTHESES	Q.A. APP'D		
GENERAL TOLERANCES	DWG APPR.		
1 DECIMAL PLACE ±0.38	ENG. REL. NO.		
2 DECIMAL PLACES ±0.25	REF. EAR#: RJ18136		
3 DECIMAL PLACES ±0.13	THIRD ANGLE PROJECTION		
ANGULAR DEGREES ±1.0°	DO NOT SCALE DRAWING		

Amphenol Canada Corp.
Commercial Products

RJ45(CAT5e) OVER USB TYPE C MODULAR, JACK, 8P8C, SHIELDED WITH TOP AND SIDE TABS, WITHOUT LED, SUITABLE FOR REFLOW PROCESS, ESD TRAY PACKAGE - RoHS COMPLIANT

DWG. NO. P-RJE4E-188-1X01

CODE ID NO. 03554 DWG SIZE: X SCALE: 5:1 SHEET 4 OF 4