



MICROCHIP

**MCP16321 Evaluation Board
User's Guide**

Note the following details of the code protection feature on Microchip devices:

- Microchip products meet the specification contained in their particular Microchip Data Sheet.
- Microchip believes that its family of products is one of the most secure families of its kind on the market today, when used in the intended manner and under normal conditions.
- There are dishonest and possibly illegal methods used to breach the code protection feature. All of these methods, to our knowledge, require using the Microchip products in a manner outside the operating specifications contained in Microchip's Data Sheets. Most likely, the person doing so is engaged in theft of intellectual property.
- Microchip is willing to work with the customer who is concerned about the integrity of their code.
- Neither Microchip nor any other semiconductor manufacturer can guarantee the security of their code. Code protection does not mean that we are guaranteeing the product as "unbreakable."

Code protection is constantly evolving. We at Microchip are committed to continuously improving the code protection features of our products. Attempts to break Microchip's code protection feature may be a violation of the Digital Millennium Copyright Act. If such acts allow unauthorized access to your software or other copyrighted work, you may have a right to sue for relief under that Act.

Information contained in this publication regarding device applications and the like is provided only for your convenience and may be superseded by updates. It is your responsibility to ensure that your application meets with your specifications. MICROCHIP MAKES NO REPRESENTATIONS OR WARRANTIES OF ANY KIND WHETHER EXPRESS OR IMPLIED, WRITTEN OR ORAL, STATUTORY OR OTHERWISE, RELATED TO THE INFORMATION, INCLUDING BUT NOT LIMITED TO ITS CONDITION, QUALITY, PERFORMANCE, MERCHANTABILITY OR FITNESS FOR PURPOSE. Microchip disclaims all liability arising from this information and its use. Use of Microchip devices in life support and/or safety applications is entirely at the buyer's risk, and the buyer agrees to defend, indemnify and hold harmless Microchip from any and all damages, claims, suits, or expenses resulting from such use. No licenses are conveyed, implicitly or otherwise, under any Microchip intellectual property rights.

Trademarks

The Microchip name and logo, the Microchip logo, dsPIC, KEELOQ, KEELOQ logo, MPLAB, PIC, PICmicro, PICSTART, PIC³² logo, rPIC and UNI/O are registered trademarks of Microchip Technology Incorporated in the U.S.A. and other countries.

FilterLab, Hampshire, HI-TECH C, Linear Active Thermistor, MXDEV, MXLAB, SEEVAL and The Embedded Control Solutions Company are registered trademarks of Microchip Technology Incorporated in the U.S.A.

Analog-for-the-Digital Age, Application Maestro, chipKIT, chipKIT logo, CodeGuard, dsPICDEM, dsPICDEM.net, dsPICworks, dsSPEAK, ECAN, ECONOMONITOR, FanSense, HI-TIDE, In-Circuit Serial Programming, ICSP, Mindi, MiWi, MPASM, MPLAB Certified logo, MPLIB, MPLINK, mTouch, Omniscient Code Generation, PICC, PICC-18, PICDEM, PICDEM.net, PICkit, PICtail, REAL ICE, rLAB, Select Mode, Total Endurance, TSHARC, UniWinDriver, WiperLock and ZENA are trademarks of Microchip Technology Incorporated in the U.S.A. and other countries.

SQTP is a service mark of Microchip Technology Incorporated in the U.S.A.

All other trademarks mentioned herein are property of their respective companies.

© 2011, Microchip Technology Incorporated, Printed in the U.S.A., All Rights Reserved.

 Printed on recycled paper.

ISBN: 978-1-61341-850-5

QUALITY MANAGEMENT SYSTEM
CERTIFIED BY DNV
== ISO/TS 16949:2009 ==

Microchip received ISO/TS-16949:2009 certification for its worldwide headquarters, design and wafer fabrication facilities in Chandler and Tempe, Arizona; Gresham, Oregon and design centers in California and India. The Company's quality system processes and procedures are for its PIC[®] MCUs and dsPIC[®] DSCs, KEELOQ[®] code hopping devices, Serial EEPROMs, microperipherals, nonvolatile memory and analog products. In addition, Microchip's quality system for the design and manufacture of development systems is ISO 9001:2000 certified.



MCP16321 EVALUATION BOARD USER'S GUIDE

Table of Contents

Preface	5
Introduction.....	5
Document Layout	5
Conventions Used in this Guide	6
Recommended Reading.....	7
The Microchip Web Site	7
Customer Support	7
Document Revision History	7
Chapter 1. Product Overview	
1.1 Introduction	9
1.2 MCP16321 Short Overview	9
1.3 What is the MCP16321 Evaluation Board?	10
1.4 MCP16321 Evaluation Board Kit Contents	10
Chapter 2. Installation and Operation	
2.1 Introduction	11
2.2 Getting Started	12
Appendix A. Schematic and Layouts	
A.1 Introduction	13
A.2 Board – Schematic	14
A.3 Board – Top Layer	15
A.4 Board – Top Copper	15
A.5 Board – Bottom Copper	16
Appendix B. Bill of Materials	
Worldwide Sales and Service	18

NOTES:



MCP16321 EVALUATION BOARD USER'S GUIDE

Preface

NOTICE TO CUSTOMERS

All documentation becomes dated, and this manual is no exception. Microchip tools and documentation are constantly evolving to meet customer needs, so some actual dialogs and/or tool descriptions may differ from those in this document. Please refer to our web site (www.microchip.com) to obtain the latest documentation available.

Documents are identified with a “DS” number. This number is located on the bottom of each page, in front of the page number. The numbering convention for the DS number is “DSXXXXA”, where “XXXX” is the document number and “A” is the revision level of the document.

For the most up-to-date information on development tools, see the MPLAB® IDE on-line help. Select the Help menu, and then Topics to open a list of available on-line help files.

INTRODUCTION

This chapter contains general information that will be useful to know before using the MCP16321 Evaluation Board. Items discussed in this chapter include:

- Document Layout
- Conventions Used in this Guide
- Recommended Reading
- The Microchip Web Site
- Customer Support
- Document Revision History

DOCUMENT LAYOUT

This document describes how to use the MCP16321 Evaluation Board. The manual layout is as follows:

- **Chapter 1. “Product Overview”** – Important information about the MCP16321 Evaluation Board.
- **Chapter 2. “Installation and Operation”** – Includes instructions on how to get started with the MCP16321 Evaluation Board and a description of the user's guide.
- **Appendix A. “Schematic and Layouts”** – Shows the schematic and layout diagrams for the MCP16321 Evaluation Board.
- **Appendix B. “Bill of Materials”** – Lists the parts used to build the MCP16321 Evaluation Board.

CONVENTIONS USED IN THIS GUIDE

This manual uses the following documentation conventions:

DOCUMENTATION CONVENTIONS

Description	Represents	Examples
Arial font:		
Italic characters	Referenced books	<i>MPLAB[®] IDE User's Guide</i>
	Emphasized text	...is the <i>only</i> compiler...
Initial caps	A window	the Output window
	A dialog	the Settings dialog
	A menu selection	select Enable Programmer
Quotes	A field name in a window or dialog	"Save project before build"
Underlined, italic text with right angle bracket	A menu path	<u><i>File>Save</i></u>
Bold characters	A dialog button	Click OK
	A tab	Click the Power tab
N'Rnnnn	A number in verilog format, where N is the total number of digits, R is the radix and n is a digit.	4'b0010, 2'hF1
Text in angle brackets < >	A key on the keyboard	Press <Enter>, <F1>
Courier New font:		
Plain Courier New	Sample source code	#define START
	Filenames	autoexec.bat
	File paths	c:\mcc18\h
	Keywords	_asm, _endasm, static
	Command-line options	-Opa+, -Opa-
	Bit values	0, 1
	Constants	0xFF, 'A'
Italic Courier New	A variable argument	<i>file.o</i> , where <i>file</i> can be any valid filename
Square brackets []	Optional arguments	mcc18 [options] <i>file</i> [options]
Curly brackets and pipe character: { }	Choice of mutually exclusive arguments; an OR selection	errorlevel {0 1}
Ellipses...	Replaces repeated text	var_name [, var_name...]
	Represents code supplied by user	void main (void) { ... }

RECOMMENDED READING

This user's guide describes how to use MCP16321 Evaluation Board. Other useful documents are listed below. The following Microchip documents are available and recommended as supplemental reference resources.

- **MCP16321/2 Data Sheet – “24V Input, 1A/2A Output, High Efficiency Synchronous Buck Regulator with Power Good Indication” (DS22285)**

THE MICROCHIP WEB SITE

Microchip provides online support via our web site at www.microchip.com. This web site is used as a means to make files and information easily available to customers. Accessible by using your favorite Internet browser, the web site contains the following information:

- **Product Support** – Data sheets and errata, application notes and sample programs, design resources, user's guides and hardware support documents, latest software releases and archived software
- **General Technical Support** – Frequently Asked Questions (FAQs), technical support requests, online discussion groups, Microchip consultant program member listing
- **Business of Microchip** – Product selector and ordering guides, latest Microchip press releases, listing of seminars and events, listings of Microchip sales offices, distributors and factory representatives

CUSTOMER SUPPORT

Users of Microchip products can receive assistance through several channels:

- Distributor or Representative
- Local Sales Office
- Field Application Engineer (FAE)
- Technical Support

Customers should contact their distributor, representative or field application engineer (FAE) for support. Local sales offices are also available to help customers. A listing of sales offices and locations is included in the back of this document.

Technical support is available through the web site at: <http://support.microchip.com>.

DOCUMENT REVISION HISTORY

Revision A (November 2011)

- Initial Release of this Document.

NOTES:

Chapter 1. Product Overview

1.1 INTRODUCTION

This chapter provides an overview of the MCP16321 Evaluation Board and covers the following topics:

- MCP16321 Short Overview
- What is the MCP16321 Evaluation Board?
- MCP16321 Evaluation Board kit contents

1.2 MCP16321 SHORT OVERVIEW

The MCP16321 is a highly integrated, 1A output current capable, high-efficiency, fixed frequency, synchronous, step-down DC-DC converter in a popular 3 mm x 3 mm 16-lead QFN package that operates from input voltage sources up to 24V. Integrated features include a low resistance high-side switch, low resistance low-side switch, 1.0 Mhz fixed-frequency peak-current mode control, internal compensation, power good output, peak current limit, V_{OUT} overvoltage and overtemperature protection. Minimal external components are necessary to develop a complete step-down DC-DC converter power supply. The MCP16321 draws less than 10 μ A while disabled.

High converter efficiency is achieved by integrating the current limited, low resistance, high-speed N-Channel MOSFETs and associated drive circuitry. Incorporating both the upper and lower switches reduces the need for external components. High switching frequency minimizes the size of external filtering components resulting in an overall small solution size.

The MCP16321 can supply 1A of continuous current while regulating the output voltage from 0.9V to 5V. An integrated high performance peak-current mode architecture keeps the output voltage tightly regulated, even during input voltage steps and output current transient conditions that are common in power systems.

The evaluation board is populated with the adjustable version of the MCP16321; V_{OUT} is set to 3.0V using an external resistor divider. The evaluation board was developed to accommodate the MCP16321 fixed output voltage options.

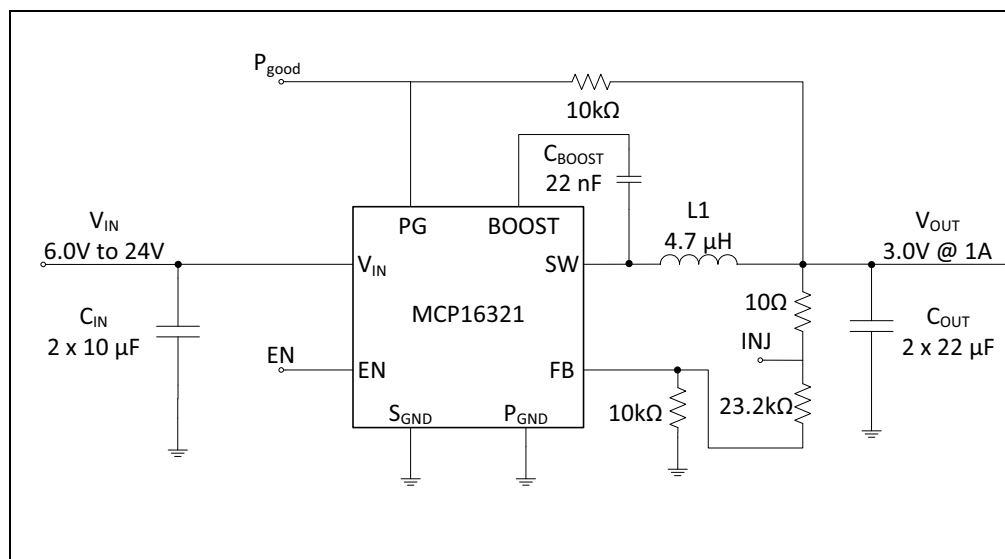

FIGURE 1-1: Typical MCP16321 Buck Application.

1.3 WHAT IS THE MCP16321 EVALUATION BOARD?

The MCP16321 Evaluation Board is designed to operate from a 6V to 24V input and regulate the output to 3.0V. Test points for input power and load are provided to demonstrate the capability of the MCP16321 Evaluation Board over the entire range. The MCP16321 Evaluation Board was designed using small surface-mount components to show application size for a high-voltage buck design. The board was designed to be the evaluation platform for the MCP16321 product.

1.4 MCP16321 EVALUATION BOARD KIT CONTENTS

This MCP16321 Evaluation Board kit includes the following items:

- MCP16321 Evaluation Board, 102-00414
- Important Information Sheet

Chapter 2. Installation and Operation

2.1 INTRODUCTION

2.1.1 MCP16321 Features

The MCP16321 devices have been developed to provide high input voltage, high current applications with a precisely regulated rail while operating at high efficiency.

The key features of the MCP16321 include:

- Up to 95% Typical Efficiency for 5V Output Applications
- Input Voltage Range: 6.0V to 24V
- Output Voltage Range: 0.9V to 5V set using external resistor divider
- 1.5% V_{REF} Accuracy
- Fixed Output Voltage Options 0.9V, 1.5V, 1.8V, 2.5V, 3.3V, 5V
- 2.0% V_{OUT} Accuracy
- Integrated High-Side N-Channel Switch: 180 m Ω
- Integrated Low-Side N-Channel Switch: 120 m Ω
- 1A Output Current MCP16321
- 1 MHz Fixed Frequency
- Adjustable Output Voltage
- Low Device Shutdown Current
- Peak Current Mode Control
- Internal Compensation
- Stable with Ceramic Capacitors
- Internal Soft-Start
- Cycle by Cycle Peak Current Limit
- Under Voltage Lockout (UVLO): 5.75V (typical)
- Output Overvoltage Protection
- Overtemperature Protection
- Available Package: 3 mm x 3 mm QFN-16 lead package

A high-performance peak-current mode control system is used to deliver a fast response to sudden line and load changes

2.1.1.1 MCP16321 EVALUATION BOARD FEATURES

The MCP16321 Evaluation Board is developed to demonstrate how the MCP16321 buck regulator operates over a wide input voltage and load range. Test points are provided for input and output voltage, allowing the MCP16321 Evaluation Board to be connected directly to a system. Test vias are also included to give the user easy access to the switch, power good, enable and injection nodes for easy evaluation of the device. There are also ancillary vias provided for attaching extra input and output connections. The 1A maximum continuous output current is available over the entire V_{IN} range, (6.0V to 24.0V), along with the entire adjustable output range (0.9V to 5.0V).

A copper via, labeled PGD, connected to the power good pin on the device, can be populated to monitor the power good output of the device. The power good pin is externally pulled up to V_{OUT} with a 10 k Ω resistor (R2). The power good output pin should not be pulled to a voltage higher than 6.0V.

A copper via, labeled INJ, connected between the 10 Ω injection resistor (R1) and the R_{TOP} resistor can be populated to allow a convenient injection point for stability analysis.

A copper via, labeled EN, connected to the enable input on the device can be populated and used to turn the MCP16321 on and off. Turning the device ON (Enable > 2.2V) when the under-voltage lockout threshold is met ($V_{IN} > 5.75V$), will enable the device. This pin must be pulled low (Enable < 0.8V) to disable the device. The EN input is internally pulled high enabling the device. It is not necessary to pull the EN input high for the device to operate and regulate output voltage. The Enable input pin should not be driven to a voltage higher than 6.0V.

A copper via, labeled SW, connected to the switch node of the device can be populated to analyze the switch node of the device.

2.2 GETTING STARTED

The MCP16321 Evaluation Board is fully assembled and tested to evaluate and demonstrate the MCP16321 operational capabilities.

2.2.1 Power Input and Output Connection

2.2.1.1 POWERING THE MCP16321 EVALUATION BOARD

The MCP16321 Evaluation Board is fully assembled, tested and ready to begin evaluation. Apply positive input voltage to the V_{IN} terminal and its return to the GND terminal. The maximum input voltage should not exceed 24V. An electronic load or resistive load can be used for evaluation, or the intended system load can be connected. Electronic loads attempt to sink current at 0V during startup; a resistive load or constant resistance is recommended for startup evaluation. Connect the positive voltage terminal of the load to the V_{OUT} terminal on the demo board and connect the negative or return side of the load to the GND terminal.

2.2.1.2 BOARD TESTING

To test the board:

1. Apply greater than 6V to the input for proper operation; no minimum load is required to regulate the output to 3.0V.
2. The EN input is internally pulled up to a low voltage internal source enabling the device. To disable the device, the EN input can be pulled below 0.8V.
3. The measured output voltage should be 3.0V typical. Adjusting the input voltage and load should not cause the output to vary significantly over the operating range of the converter.



MCP16321 EVALUATION BOARD USER'S GUIDE

Appendix A. Schematic and Layouts

A.1 INTRODUCTION

This appendix contains the following schematics and layouts for the MCP16321 Evaluation Board:

- Board – Schematic
- Board – Top Layer
- Board – Top Copper Layer
- Board – Bottom Copper Layer

A.3 BOARD – TOP LAYER

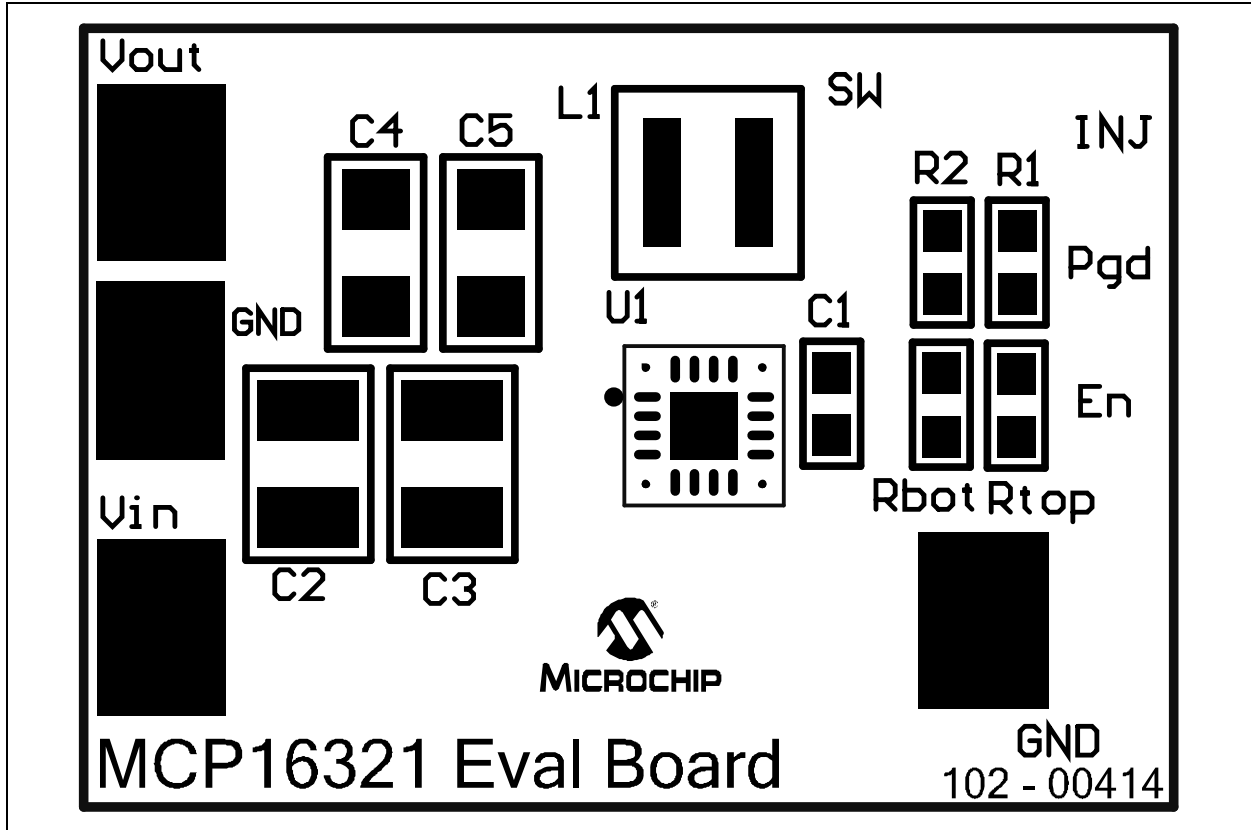

A.4 BOARD – TOP COPPER

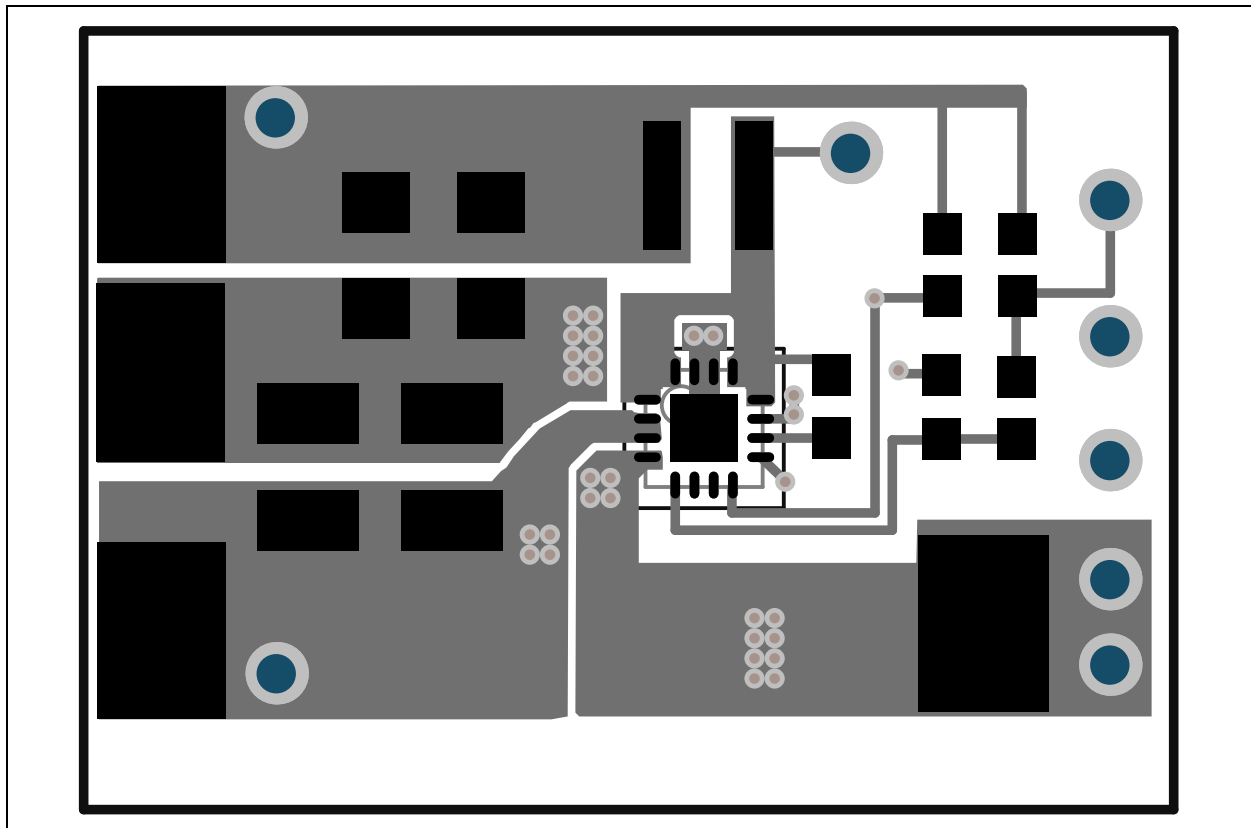

A.5 BOARD – BOTTOM COPPER

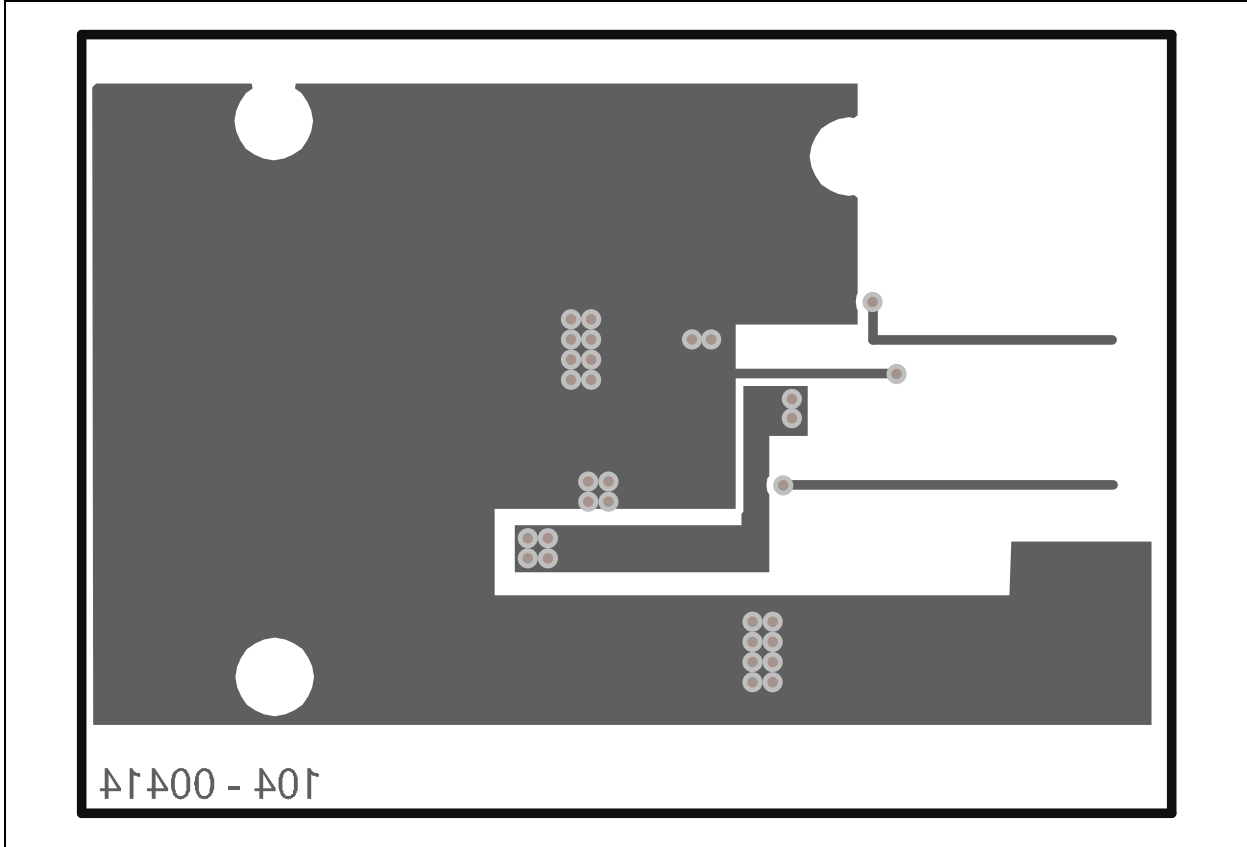

Appendix B. Bill of Materials

TABLE B-1: BILL OF MATERIALS (BOM)

Qty	Reference	Description	Manufacturer	Part Number
1	C1	CAP 22000pF 25V CERAMIC X7R 0603 10%	AVX Corporation	0603YC104KAT2A
2	C2, C3	CAP 10uF 35V CERAMIC X7R 1210 20%	Taiyo Yuden	GMK325AB7106MM-T
2	C4, C5	CAP 22uF 6.3V CERAMIC X7R 1206 10%	Murata	GCM31CR70J226KE23L
1	L1	XFL4020 4.7uH Shielded Power Inductor	Coilcraft	XFL4020-472MEB
1	PCB	MCP16321 6V to 24V VIN, 3.3V Printed Circuit Board	Microchip Technology Inc.	104-00414
1	R1	RES 10.0 OHM 1/10W 1% 0603 SMD	Yageo	RC0603FR-0710RL
1	R2, Rbot	RES 10.0K OHM 1/10W 1% 0603 SMD	Yageo	RC0603FR-0710KL
1	Rtop	RES 23.2K OHM 1/10W 1% 0603 SMD	Yageo	RC0603FR-0723K2L
1	U1	MCP16321 High Input Buck Converter QFN16	Microchip Technology Inc.	MCP16321
4	VIN, VOUT, GND, GND	PC TEST POINT COMPACT SMT	Keystone	5016

Note 1: The components listed in this Bill of Materials are representative of the PCB assembly. The released BOM used in manufacturing uses all RoHS-compliant components.



MICROCHIP

Worldwide Sales and Service

AMERICAS

Corporate Office
2355 West Chandler Blvd.
Chandler, AZ 85224-6199
Tel: 480-792-7200
Fax: 480-792-7277
Technical Support:
<http://www.microchip.com/support>
Web Address:
www.microchip.com

Atlanta
Duluth, GA
Tel: 678-957-9614
Fax: 678-957-1455

Boston
Westborough, MA
Tel: 774-760-0087
Fax: 774-760-0088

Chicago
Itasca, IL
Tel: 630-285-0071
Fax: 630-285-0075

Cleveland
Independence, OH
Tel: 216-447-0464
Fax: 216-447-0643

Dallas
Addison, TX
Tel: 972-818-7423
Fax: 972-818-2924

Detroit
Farmington Hills, MI
Tel: 248-538-2250
Fax: 248-538-2260

Indianapolis
Noblesville, IN
Tel: 317-773-8323
Fax: 317-773-5453

Los Angeles
Mission Viejo, CA
Tel: 949-462-9523
Fax: 949-462-9608

Santa Clara
Santa Clara, CA
Tel: 408-961-6444
Fax: 408-961-6445

Toronto
Mississauga, Ontario,
Canada
Tel: 905-673-0699
Fax: 905-673-6509

ASIA/PACIFIC

Asia Pacific Office
Suites 3707-14, 37th Floor
Tower 6, The Gateway
Harbour City, Kowloon
Hong Kong
Tel: 852-2401-1200
Fax: 852-2401-3431

Australia - Sydney
Tel: 61-2-9868-6733
Fax: 61-2-9868-6755

China - Beijing
Tel: 86-10-8569-7000
Fax: 86-10-8528-2104

China - Chengdu
Tel: 86-28-8665-5511
Fax: 86-28-8665-7889

China - Chongqing
Tel: 86-23-8980-9588
Fax: 86-23-8980-9500

China - Hangzhou
Tel: 86-571-2819-3187
Fax: 86-571-2819-3189

China - Hong Kong SAR
Tel: 852-2401-1200
Fax: 852-2401-3431

China - Nanjing
Tel: 86-25-8473-2460
Fax: 86-25-8473-2470

China - Qingdao
Tel: 86-532-8502-7355
Fax: 86-532-8502-7205

China - Shanghai
Tel: 86-21-5407-5533
Fax: 86-21-5407-5066

China - Shenyang
Tel: 86-24-2334-2829
Fax: 86-24-2334-2393

China - Shenzhen
Tel: 86-755-8203-2660
Fax: 86-755-8203-1760

China - Wuhan
Tel: 86-27-5980-5300
Fax: 86-27-5980-5118

China - Xian
Tel: 86-29-8833-7252
Fax: 86-29-8833-7256

China - Xiamen
Tel: 86-592-2388138
Fax: 86-592-2388130

China - Zhuhai
Tel: 86-756-3210040
Fax: 86-756-3210049

ASIA/PACIFIC

India - Bangalore
Tel: 91-80-3090-4444
Fax: 91-80-3090-4123

India - New Delhi
Tel: 91-11-4160-8631
Fax: 91-11-4160-8632

India - Pune
Tel: 91-20-2566-1512
Fax: 91-20-2566-1513

Japan - Osaka
Tel: 81-66-152-7160
Fax: 81-66-152-9310

Japan - Yokohama
Tel: 81-45-471-6166
Fax: 81-45-471-6122

Korea - Daegu
Tel: 82-53-744-4301
Fax: 82-53-744-4302

Korea - Seoul
Tel: 82-2-554-7200
Fax: 82-2-558-5932 or
82-2-558-5934

Malaysia - Kuala Lumpur
Tel: 60-3-6201-9857
Fax: 60-3-6201-9859

Malaysia - Penang
Tel: 60-4-227-8870
Fax: 60-4-227-4068

Philippines - Manila
Tel: 63-2-634-9065
Fax: 63-2-634-9069

Singapore
Tel: 65-6334-8870
Fax: 65-6334-8850

Taiwan - Hsin Chu
Tel: 886-3-5778-366
Fax: 886-3-5770-955

Taiwan - Kaohsiung
Tel: 886-7-536-4818
Fax: 886-7-330-9305

Taiwan - Taipei
Tel: 886-2-2500-6610
Fax: 886-2-2508-0102

Thailand - Bangkok
Tel: 66-2-694-1351
Fax: 66-2-694-1350

EUROPE

Austria - Wels
Tel: 43-7242-2244-39
Fax: 43-7242-2244-393

Denmark - Copenhagen
Tel: 45-4450-2828
Fax: 45-4485-2829

France - Paris
Tel: 33-1-69-53-63-20
Fax: 33-1-69-30-90-79

Germany - Munich
Tel: 49-89-627-144-0
Fax: 49-89-627-144-44

Italy - Milan
Tel: 39-0331-742611
Fax: 39-0331-466781

Netherlands - Drunen
Tel: 31-416-690399
Fax: 31-416-690340

Spain - Madrid
Tel: 34-91-708-08-90
Fax: 34-91-708-08-91

UK - Wokingham
Tel: 44-118-921-5869
Fax: 44-118-921-5820

11/29/11