

Product Specification

1000BASE-T Copper GBIC Transceivers

FCL-8520/8521-3

Product Features

- Up to 1.25Gb/s bi-directional data links
- RoHS compliant and Lead Free
- Extended operating temperature range (0°C to +75°C)
- Hot-pluggable
- Fully metallic enclosure for low EMI
- Low power (1.5W typical)
- Access to physical layer IC via 2-wire serial bus



Applications

- 1.25 Gigabit Ethernet over Cat 5 cable

Finisar's FCL-8520/8521-3 1000BASE-T Copper GBIC transceivers are based on the GBIC Specification Revision 5.5¹. They are compatible with the Gigabit Ethernet and 1000BASE-T standards as specified in IEEE Std 802.3z² and IEEE Std 802.3ab³.

The FCL-8520-3 uses the GBIC's RX_LOS pin for link indication, and 1000BASE-X auto-negotiation must be disabled on the host system. The FCL-8521-3 is compatible with 1000BASE-X auto-negotiation, but does not have a link indication feature (RX_LOS is internally grounded). See AN-2032, "Commonly Asked Questions Regarding Auto-negotiation on Finisar's 1000BASE-T GBICs"⁴, for a more complete explanation on the differences between the two models.

PRODUCT SELECTION

Part Number	Link Indicator on RX_LOS Pin	Compatible with 1000BASE-X Auto-negotiation
FCL-8520-3	Yes	No
FCL-8521-3	No	Yes

I. GBIC to Host Connector Pin Out

Pin Name	Pin #	Sequence
RX_LOS*	1	2
GND	2	2
GND	3	2
MOD_DEF(0)	4	2
MOD_DEF(1)	5	2
MOD_DEF(2)	6	2
TX_DISABLE	7	2
GND	8	2
GND	9	2
GND	10	2
GND	11	1
-RX_DAT	12	1
+RX_DAT	13	1
GND	14	1
V _{CC}	15	2
V _{CC}	16	2
GND	17	1
+TX_DAT	18	1
-TX_DAT	19	1
GND	20	1

Note: RX_LOS is used for link indication on the FCL-8520-3, and is internally grounded on the FCL-8521-3

Table 1. GBIC to host connector pin assignment

“Sequence” indicates the order in which pins make contact when the device is hot plugged. For additional information, see “Table 3: Signal Definitions” in the GBIC Specification Revision 5.5.¹

II. +5V Volt Electrical Power Interface

The FCL-8520/8521-3 has an extended input voltage range of 4.5 to 5.5 V, compared to the GBIC standard of 4.25 to 5.25 V. The 6V maximum voltage is not allowed for continuous operation.

+5 Volt Electrical Power Interface						
Parameter	Symbol	Min	Typ	Max	Units	Notes/Conditions
Supply Current	I_s		310	375	mA	1.7W max power over full range of voltage and temperature. See Note 1.
Input Voltage	V_{cc}	4.5	5	5.5	V	Referenced to GND.
Maximum Voltage	V_{max}			6	V	
Surge Current	I_{surge}			450	mA	Hot plug. See Note 1.

Table 2. +5 Volt electrical power interface

Note:

1. **Caution:** Power consumption and inrush current are higher than the specified values in the GBIC Specification Rev 5.5¹.

III. Low-Speed Signals

RX_LOS is a TTL signals as described in Table 3 and 4. MOD_DEF(1) (SCL) and MOD_DEF(2) (SDA), are open drain CMOS signals (see section VII, “Serial Communication Protocol”). Both MOD_DEF(1) and MOD_DEF(2) must be pulled up to host_Vcc. For more detailed information, see sections 5.3.1 – 5.3.8 in the GBIC Specification Rev. 5.5¹.

Low-Speed Signals, Electronic Characteristics						
Parameter	Symbol	Min	Max	Units	Notes/Conditions	
GBIC Output LOW	V_{OL}	0	0.5	V	4.7k to 10k pull-up to host_Vcc, measured at host side of connector	
GBIC Output HIGH	V_{OH}	host_Vcc - 0.5	host_Vcc + 0.3	V	4.7k to 10k pull-up to host_Vcc, measured at host side of connector	
GBIC Input LOW	V_{IL}	0	0.8	V	4.7k to 10k pull-up to Vcc, measured at GBIC side of connector	
GBIC Input HIGH	V_{IH}	2	Vcc + 0.3	V	4.7k to 10k pull-up to Vcc, measured at GBIC side of connector	

Table 3. Low-speed signals, electronic characteristics

High-Speed Electrical Interface, Transmission Line-GBIC						
Parameter	Symbol	Min	Typ	Max	Units	Notes/Conditions
Line Frequency	f_L		125		MHz	5-level encoding, per IEEE 802.3ab.
Tx Output Impedance	$Z_{out,TX}$		100		Ohm	Differential, for all frequencies between 1MHz and 125MHz.
Rx Input Impedance	$Z_{in,RX}$		100		Ohm	Differential, for all frequencies between 1MHz and 125MHz.

Table 4. High-speed electrical interface, transmission line-GBIC

IV. High-Speed Electrical Interface

All high-speed signals are AC-coupled internally.

High-Speed Electrical Interface, Host-GBIC						
Parameter	Symbol	Min	Typ	Max	Units	Notes/Conditions
Differential Input Voltage	V_{indiff}	0.50		2.00	V	Differential peak - peak
Differential Output Voltage	$V_{outdiff}$	0.37		2.00	V	Differential peak - peak
Rise/Fall Time	T_r, T_f		250		psec	20%-80% Differential
Tx Input Impedance	Z_{in}		75		Ohm	
Rx Output Impedance	Z_{out}		75		Ohm	

Table 5. High-speed electrical interface, host-GBIC

V. General Specifications

General						
Parameter	Symbol	Min	Typ	Max	Units	Notes/Conditions
Data Rate	BR			1.25	Gb/sec	IEEE 802.3 compatible. See Notes 1 and 2 below.
Cable Length	L			100	m	Category 5 UTP. BER $<10^{-10}$

Table 6. General specifications

Notes:

1. Clock tolerance is ± 50 ppm
2. The FCL-8520/8521-3 is a full-duplex device in the "Preferred Master" mode.
3. Automatic crossover detection is enabled. External crossover cable is not required

VI. Environmental Specifications

The FCL-8520/8521-3 has an extended range from 0°C to +75°C case temperature as specified in Table 8.

Environmental Specifications						
Parameter	Symbol	Min	Typ	Max	Units	Notes/Conditions
Operating Temperature	T _{op}	0		75	°C	Case temperature
Storage Temperature	T _{sto}	-40		85	°C	Ambient temperature

Table 7. Environmental specifications

VII. Serial Communication Protocol

All Finisar GBICs are ‘Module Definition “4”’ and support the 2-wire serial communication protocol outlined in the GBIC Specification¹. These GBICs use an Atmel AT24C01A 128 byte E²PROM with an address of A0h. For details on interfacing with the E²PROM, see the Atmel data sheet titled “AT24C01A/02/04/08/16 2-Wire Serial CMOS E²PROM.”⁵

The 1000BASE-T physical layer IC can also be accessed via the 2-wire serial bus at address A4h. For details interfacing with the PHY IC, see Marvell data sheet titled “Alaska Ultra 88E1011/88E1001S Integrated Gigabit Ethernet Transceiver”⁶ (Marvell document number MV-5100281-00).

Serial Bus Timing Requirements						
Parameter	Symbol	Min	Typ	Max	Units	Notes/Conditions
I ² C Clock Rate		0		100,000	Hz	

Table 8. Serial bus timing requirements

VIII. Mechanical Specifications

The host-side of the FCL-8520/8521-3 conforms to the mechanical specifications outlined in the GBIC Specification Revision 5.5, Section 6¹. The front portion of the GBIC (part extending beyond the face plate of the host) is larger to accommodate the RJ-45 connector. See Figure 1 below for details.

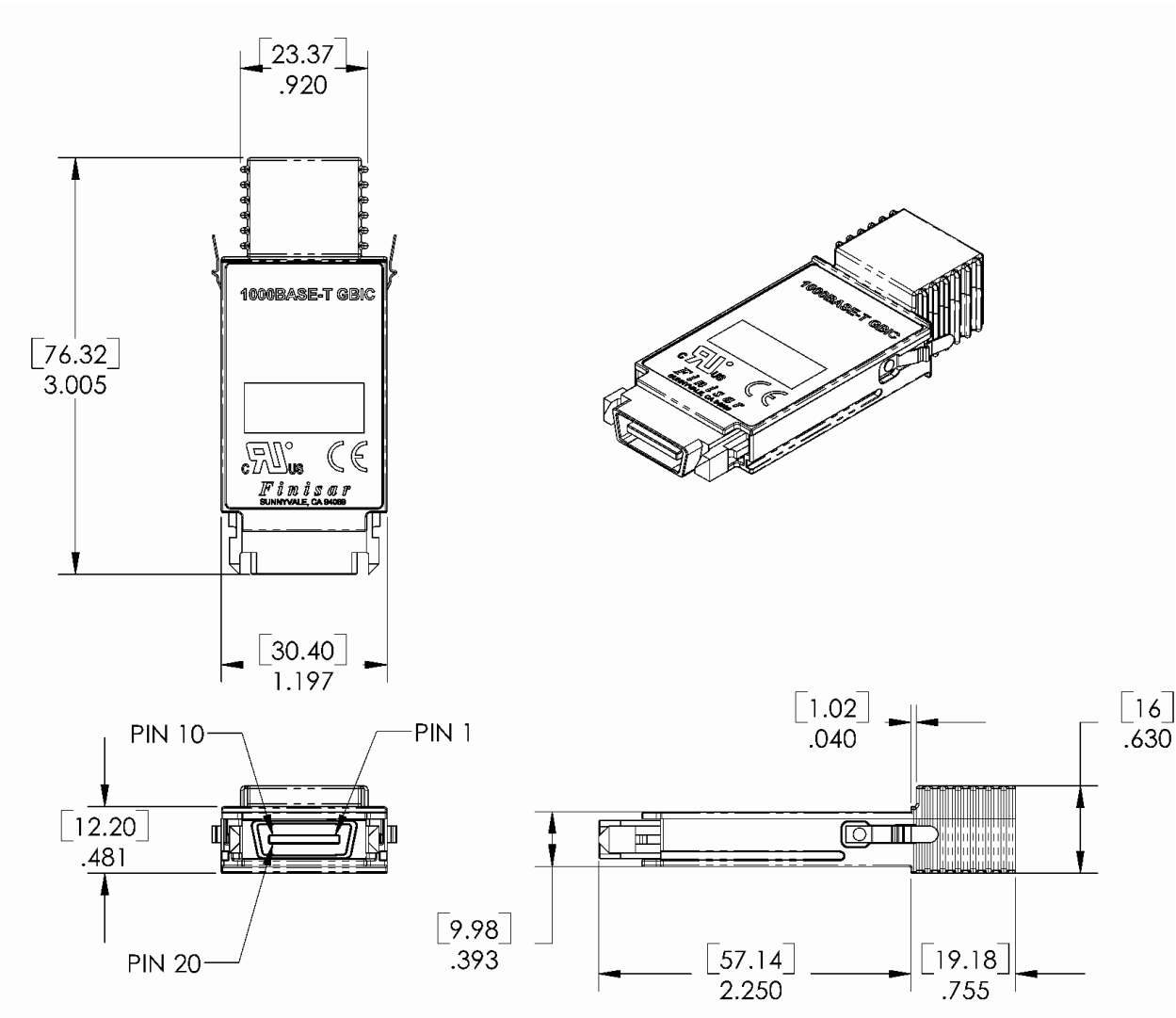

Figure 1. FCL-8520/8521-3 mechanical dimensions

IX. References

1. "Gigabit Interface Converter (GBIC) Revision 5.5". Sun Microsystems Computer Company et. al., September 27, 2000. <http://playground.sun.com/pub/OEmod/>
2. IEEE Std 802.3z. IEEE Standards Department, 2000.
3. "IEEE Std 802.3ab-1999 'Physical Layer Parameters and Specifications for 1000 Mb/s Operation Over 4-Pair of Category 5 Balanced Copper Cabling, Type 1000BASE-T". IEEE Standards Department, 1999.
4. "Application Note AN-XXXX: Commonly Asked Questions Regarding Auto-negotiation on Finisar's 1000BASE-T GBICs", Finisar Corporation, February 2003
5. "AT24C01A/02/04/08/16 2-Wire Serial CMOS E²PROM". Atmel Corporation. www.Atmel.com
6. "Alaska Ultra 88E1011/88E1001S Integrated 10/100/1000 Gigabit Ethernet Transceiver". Marvell Corporation. www.marvell.com

X. For More Information

Finisar Corporation
1389 Moffett Park Drive
Sunnyvale, CA 94089-1133
Tel. 1-408-548-1000
Fax 1-408-541-6138
sales@finisar.com
www.finisar.com