

32-Channel High-Voltage Amplifier Array

Features

- Thirty-two Independent High-voltage Amplifiers
- 300V Operating Voltage
- 295V Output Voltage
- 2.2V/ μ s Typical Output Slew Rate
- Adjustable Output Current Source Limit
- Adjustable Output Current Sink Limit
- Internal Closed-loop Gain of 72V/V
- 12 M Ω Feedback Impedance
- Layout Ideal for Die Applications

Applications

- Microelectromechanical Systems (MEMS) Driver
- Piezoelectric Transducer Driver
- Optical Crosspoint Switches
(Using MEMS Technology)

General Description

The HV256 is a 32-channel, high-voltage amplifier array integrated circuit. It operates on a single high-voltage supply, up to 300V, and two low-voltage supplies, V_{DD} and V_{NN} .

The input voltage range is from 0V to 4.096V. The internal closed-loop gain is 72V/V, giving an output voltage of 295V when 4.096V is applied. Input voltages of up to 5V can be applied but will cause the output to saturate. The maximum output voltage swing is 5V below the V_{PP} high-voltage supply. The outputs can drive capacitive loads of up to 3000 pF.

The maximum output source and sink currents can be adjusted by using two external resistors. An external R_{SOURCE} resistor controls the maximum sourcing current, and an external R_{SINK} resistor controls the maximum sinking current. The current limit is approximately 12.5V divided by the external resistor value. The setting is common for all 32 outputs. A low-voltage silicon junction diode is made available to help monitor the die temperature.

Package Type

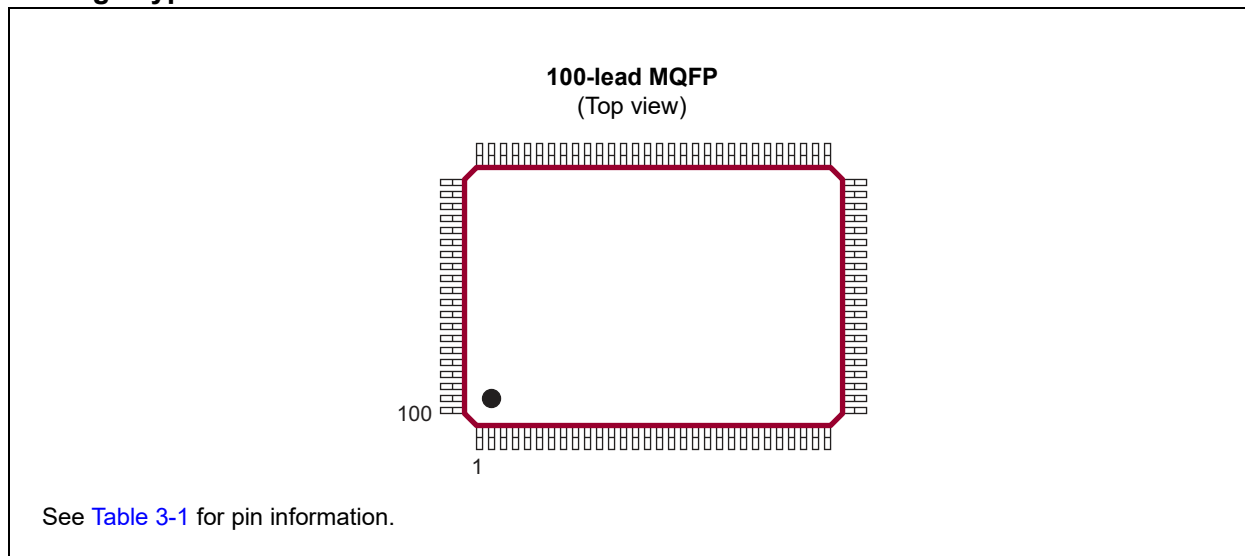

HV256

Functional Block Diagram

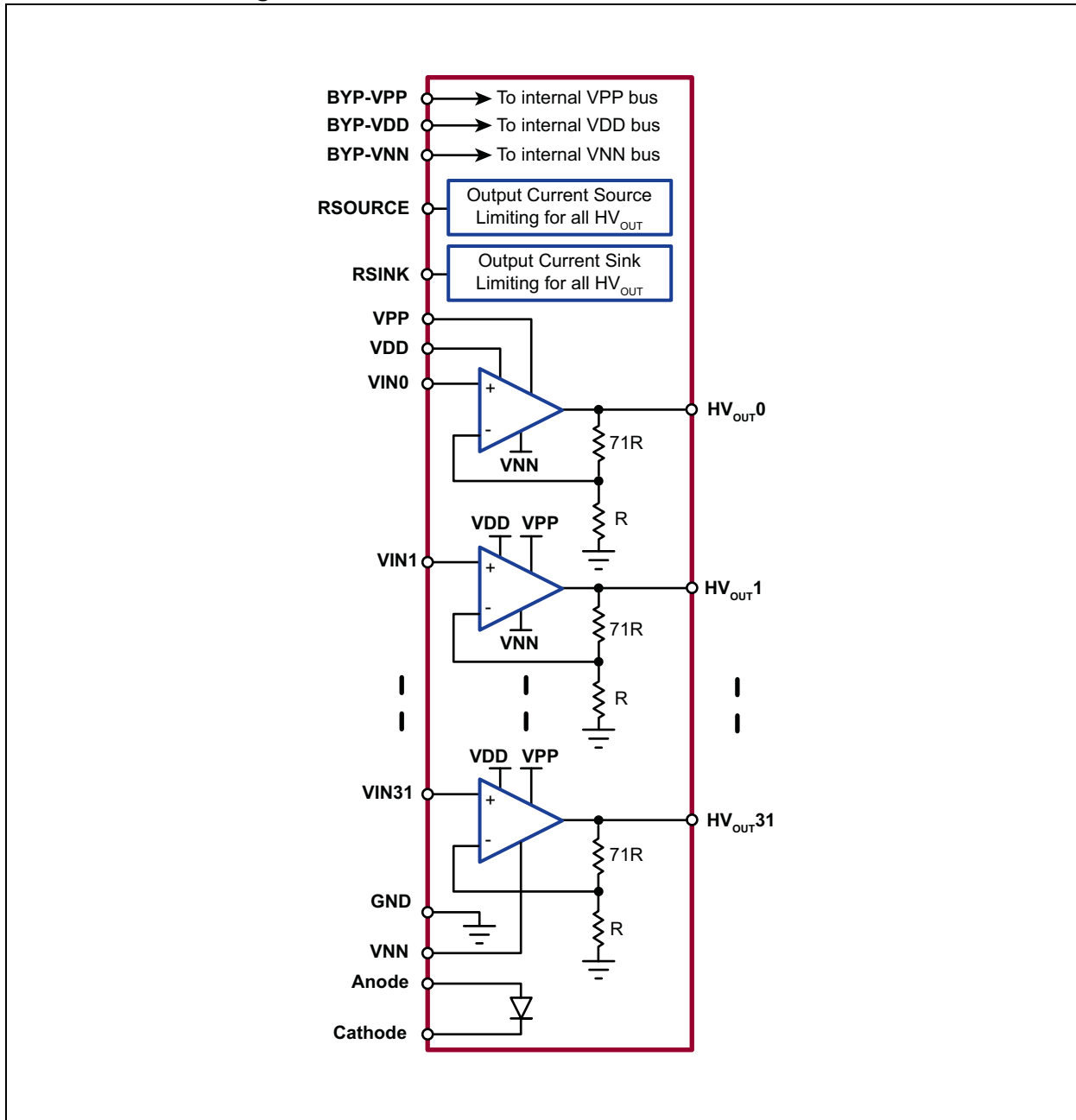

Typical Application Circuit

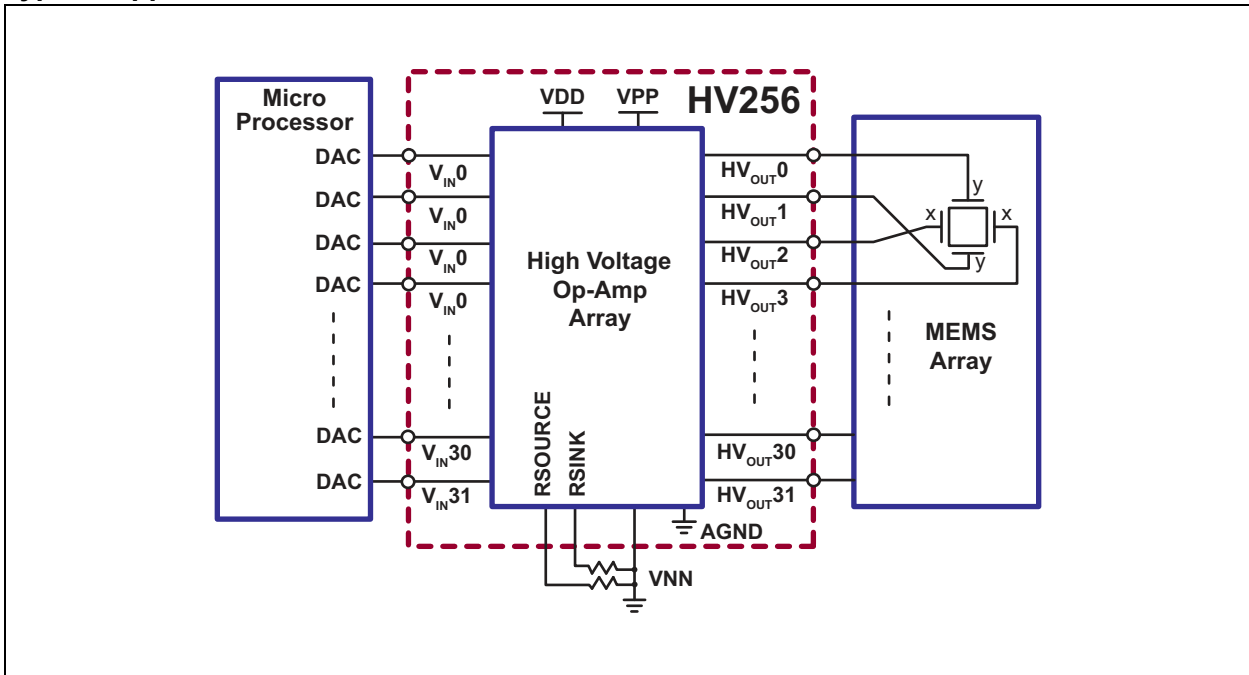

HV256

1.0 ELECTRICAL CHARACTERISTICS

Absolute Maximum Ratings†

High-voltage Supply, V_{PP}	310V
Analog Low-voltage Positive Supply, AV_{DD}	8V
Digital Low-voltage Positive Supply, DV_{DD}	8V
Analog Low-voltage Negative Supply, AV_{NN}	-7V
Digital Low-voltage Negative Supply, DV_{NN}	-7V
Logic Input Voltage	-0.5V to DV_{DD}
Analog Input Signal, V_{IN}	0V to 6V
Maximum Junction Temperature, T_J	150°C
Storage Temperature, T_S	-65°C to +150°C

† **Notice:** Stresses above those listed under “Absolute Maximum Ratings” may cause permanent damage to the device. This is a stress rating only, and functional operation of the device at those or any other conditions above those indicated in the operational sections of this specification is not intended. Exposure to maximum rating conditions for extended periods may affect device reliability.

RECOMMENDED OPERATING CONDITIONS

Electrical Specifications: Unless otherwise indicated, $T_A = +25^\circ\text{C}$.						
Parameter	Sym.	Min.	Typ.	Max.	Unit	Conditions
High-voltage Positive Supply	V_{PP}	125	—	300	V	
Low-voltage Positive Supply	V_{DD}	6	—	7.5	V	
Low-voltage Negative Supply	V_{NN}	-4.5	—	-6.5	V	
V_{PP} Supply Current	I_{PP}	—	—	0.8	mA	$V_{PP} = 300\text{V}$, All $HV_{OUT} = 0\text{V}$, No load
V_{DD} Supply Current	I_{DD}	—	—	5	mA	$V_{DD} = 6\text{V}$ to 7.5V
V_{NN} Supply Current	I_{NN}	-6	—	—	mA	$V_{NN} = -4.5\text{V}$ to -6.5V
Operating Temperature Range	T_J	-10	—	85	°C	

DC ELECTRICAL CHARACTERISTICS

Electrical Specifications: Unless otherwise indicated, $T_A = +25^\circ\text{C}$.						
Parameter	Sym.	Min.	Typ.	Max.	Unit	Conditions
HV_{OUT} Voltage Swing	HV_{OUT}	0	—	$V_{PP}-5$	V	
Input Voltage Range	V_{IN}	0	—	5	V	
Input Voltage Offset	V_{INOS}	—	—	±50	mV	Input referred
Feedback Resistance from HV_{OUT} to Ground	R_{FB}	9.6	12	—	MΩ	
HV_{OUT} Capacitive Load	C_{LOAD}	0	—	3000	pF	Note 2
HV_{OUT} Sourcing Current Limiting Range	I_{SOURCE}	385	550	715	μA	$R_{SOURCE} = 25\text{ k}\Omega$
HV_{OUT} Sinking Current Limiting Range	I_{SINK}	385	550	715	μA	$R_{SINK} = 25\text{ k}\Omega$
External Resistance Range for Setting Maximum Current Source	R_{SOURCE}	25	—	250	kΩ	
External Resistance Range for Setting Maximum Current Sink	R_{SINK}	25	—	250	kΩ	

Note 1: This parameter is characterized, not 100% tested.

Note 2: This parameter is for design guidance only.

AC ELECTRICAL CHARACTERISTICS

Electrical Specifications: Unless otherwise indicated, $T_A = +25^\circ\text{C}$.						
Parameter	Sym.	Min.	Typ.	Max.	Unit	Conditions
HV _{OUT} Slew Rate Rise	SR	—	2.2	—	V/ μs	No load
HV _{OUT} Slew Rate Fall		—	2	—	V/ μs	No load
HV _{OUT} -3 dB Channel Bandwidth	BW	—	4	—	kHz	$V_{PP} = 300\text{V}$ (Note 1)
Open-loop Gain	A _O	70	100	—	dB	Note 1
Closed-loop Gain	A _V	68.4	72	75.6	V/V	
DC Channel-to-channel Crosstalk	CT _{DC}	-80	—	—	dB	Note 2
Power Supply Rejection Ratio for V_{PP} , V_{DD} and V_{NN}	PSRR	-40	—	—	dB	Note 1
TEMPERATURE DIODE						
Peak Inverse Voltage	PIV	—	—	5	V	Cathode to anode (Note 2)
Forward Diode Drop	V _F	—	0.6	—	V	$I_F = 100\ \mu\text{A}$, anode to cathode at $T_A = 25^\circ\text{C}$
Forward Diode Current	I _F	—	—	100	μA	Anode to cathode
V _F Temperature Coefficient	T _C	—	-2.2	—	mV/ $^\circ\text{C}$	Anode to cathode (Note 1)

Note 1: This parameter is characterized, not 100% tested.

Note 2: This parameter is for design guidance only.

TEMPERATURE SPECIFICATIONS

Parameter	Sym.	Min.	Typ.	Max.	Unit	Conditions
TEMPERATURE RANGE						
Maximum Junction Temperature	T _J	—	—	+150	$^\circ\text{C}$	
Storage Temperature	T _S	-65	—	+150	$^\circ\text{C}$	
PACKAGE THERMAL RESISTANCE						
100-lead MQFP	θ_{JA}	—	39	—	$^\circ\text{C}/\text{W}$	

2.0 TYPICAL PERFORMANCE CURVES

Note: The graphs and tables provided following this note are a statistical summary based on a limited number of samples and are provided for informational purposes only. The performance characteristics listed herein are not tested or guaranteed. In some graphs or tables, the data presented may be outside the specified operating range (e.g. outside specified power supply range) and therefore outside the warranted range.

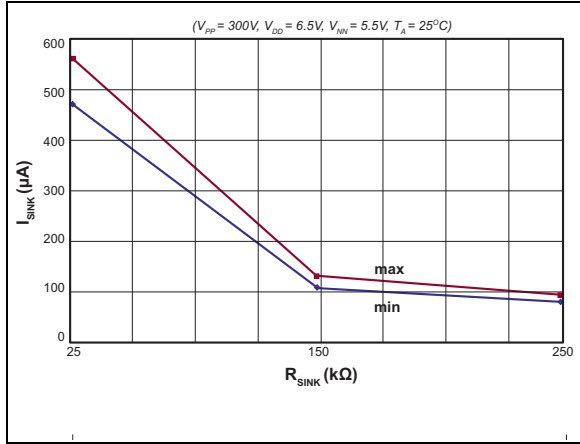

FIGURE 2-1: I_{SINK} vs. R_{SINK} .

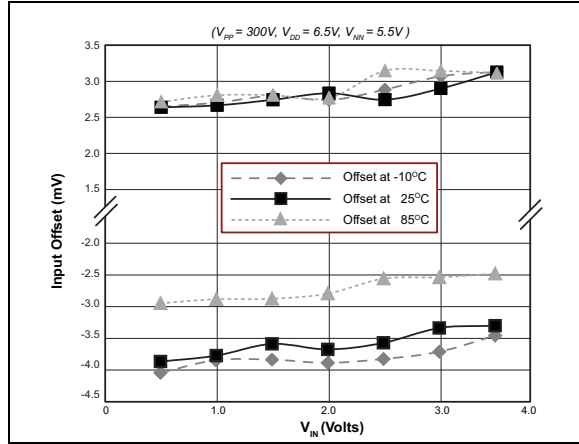

FIGURE 2-4: Input Offset vs. V_{IN} and Temperature.

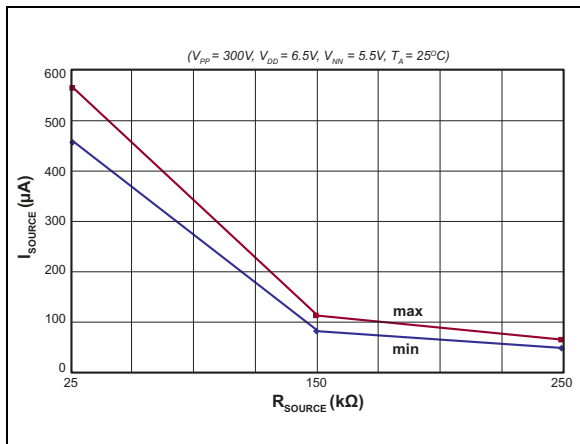

FIGURE 2-2: I_{SOURCE} vs. R_{SOURCE} .

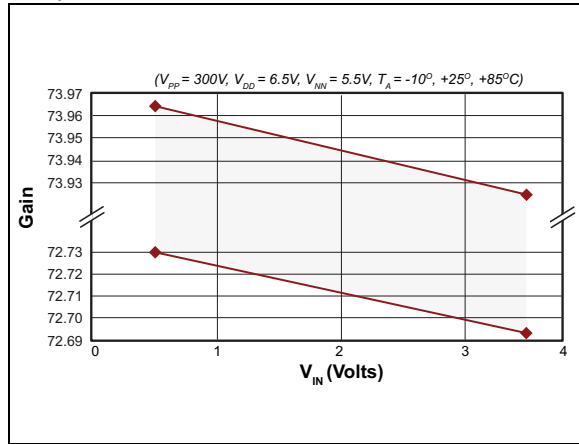

FIGURE 2-5: Gain vs. V_{IN} .

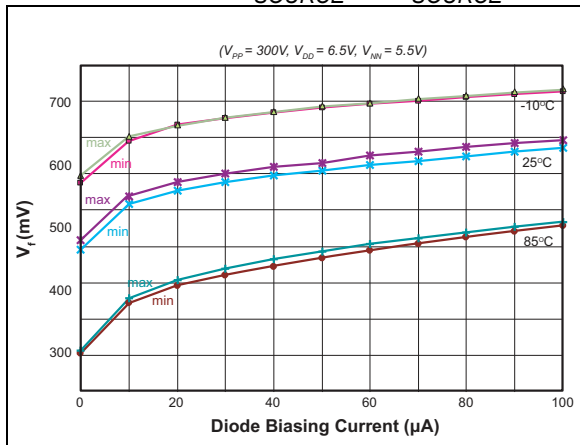

FIGURE 2-3: Temperature Diode vs. Temperature.

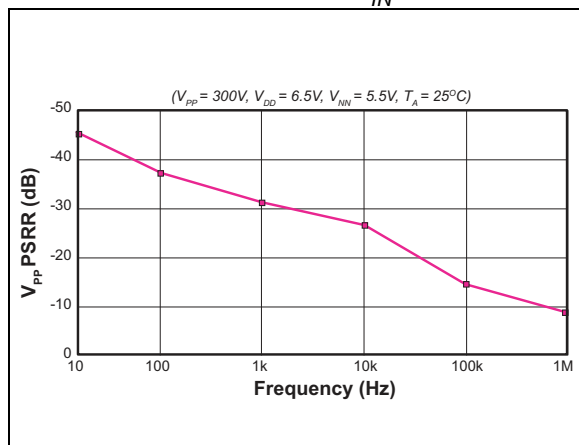

FIGURE 2-6: V_{PP} PSRR vs. Frequency.

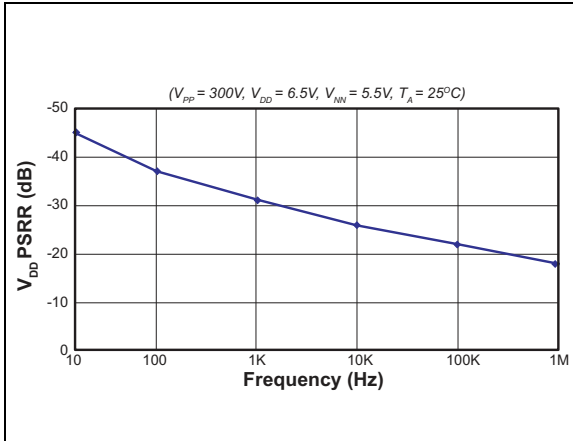

FIGURE 2-7: V_{DD} PSRR vs. Frequency.

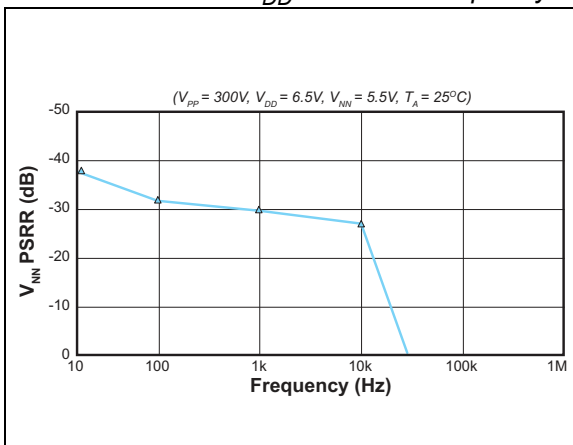

FIGURE 2-8: V_{NN} PSRR vs. Frequency.

HV256

3.0 PIN DESCRIPTION

The details on the pins of HV256 are listed on [Table 3-1](#). Refer to [Package Type](#) for the location of pins.

TABLE 3-1: PIN FUNCTION TABLE

Pin Number	Pin Name	Description
1	HVOUT31	Amplifier output
2	HVOUT30	Amplifier output
3	HVOUT29	Amplifier output
4	HVOUT28	Amplifier output
5	HVOUT27	Amplifier output
6	HVOUT26	Amplifier output
7	HVOUT25	Amplifier output
8	HVOUT24	Amplifier output
9	HVOUT23	Amplifier output
10	HVOUT22	Amplifier output
11	HVOUT21	Amplifier output
12	HVOUT20	Amplifier output
13	HVOUT19	Amplifier output
14	HVOUT18	Amplifier output
15	HVOUT17	Amplifier output
16	HVOUT16	Amplifier output
17	HVOUT15	Amplifier output
18	HVOUT14	Amplifier output
19	HVOUT13	Amplifier output
20	HVOUT12	Amplifier output
21	HVOUT11	Amplifier output
22	HVOUT10	Amplifier output
23	HVOUT9	Amplifier output
24	HVOUT8	Amplifier output
25	HVOUT7	Amplifier output
26	HVOUT6	Amplifier output
27	HVOUT5	Amplifier output
28	HVOUT4	Amplifier output
29	HVOUT3	Amplifier output
30	HVOUT2	Amplifier output
31	HVOUT1	Amplifier output
32	HVOUT0	Amplifier output
33	VPP	High-voltage positive supply.
34	NC	No connect
35	NC	No connect

TABLE 3-1: PIN FUNCTION TABLE (CONTINUED)

Pin Number	Pin Name	Description
36	NC	No connect
37	NC	No connect
38	NC	No connect
39	GND	Digital ground.
40	VNN	Analog low-voltage negative supply.
41	NC	No connect
42	VDD	Analog low-voltage positive supply.
43	GND	Digital ground.
44	VNN	Analog low-voltage negative supply.
45	VDD	Analog low-voltage positive supply.
46	NC	No connect
47	NC	No connect
48	VIN0	Amplifier input
49	VIN1	Amplifier input
50	VIN2	Amplifier input
51	VIN3	Amplifier input
52	VIN4	Amplifier input
53	VIN5	Amplifier input
54	VIN6	Amplifier input
55	VIN7	Amplifier input
56	VIN8	Amplifier input
57	VIN9	Amplifier input
58	VIN10	Amplifier input
59	VIN11	Amplifier input
60	VIN12	Amplifier input
61	VIN13	Amplifier input
62	VIN14	Amplifier input
63	VIN15	Amplifier input
64	VIN16	Amplifier input
65	VIN17	Amplifier input
66	VIN18	Amplifier input
67	VIN19	Amplifier input
68	VIN20	Amplifier input
69	VIN21	Amplifier input
70	VIN22	Amplifier input
71	VIN23	Amplifier input
72	VIN24	Amplifier input
73	VIN25	Amplifier input
74	VIN26	Amplifier input

HV256

TABLE 3-1: PIN FUNCTION TABLE (CONTINUED)

Pin Number	Pin Name	Description
75	VIN27	Amplifier input
76	VIN28	Amplifier input
77	VIN29	Amplifier input
78	VIN30	Amplifier input
79	VIN31	Amplifier input
80	NC	No connect
81	NC	No connect
82	NC	No connect
83	NC	No connect
84	NC	No connect
85	NC	No connect
86	GND	Digital ground.
87	VDD	Analog low-voltage positive supply.
88	VNN	Analog low-voltage negative supply.
89	GND	Digital ground.
90	NC	No connect
91	VDD	Analog low-voltage positive supply.
92	BYP-VNN	A low-voltage 1 nF to 10 nF decoupling capacitor across VNN and BYP-VNN is required.
93	BYP-VDD	A low voltage 1 nF to 10 nF decoupling capacitor across VDD and BYP-VDD is required.
94	VNN	Analog low-voltage negative supply.
95	ANODE	The anode side of a low-voltage silicon diode that can be used to monitor die temperature
96	CATHODE	The cathode side of a low-voltage silicon diode that can be used to monitor die temperature
97	RSINK	The external resistor from RSINK to VNN that sets the output current sinking limit. The current limit is approximately 12.5V divided by the RSINK resistor value.
98	RSOURCE	The external resistor from RSOURCE to VNN that sets the output current sourcing limit. The current limit is approximately 12.5V divided by the RSOURCE resistor value.
99	BYP-VPP	A low-voltage 1 nF to 10 nF decoupling capacitor across VPP and BYP-VPP is required.
100	VPP	High-voltage positive supply.

4.0 FUNCTIONAL DESCRIPTION

4.1 Power-up/Power-down Sequence

4.1.1 EXTERNAL DIODE PROTECTION

The device can be damaged due to improper power-up/power-down sequence. To avoid this, please follow the acceptable power-up and power-down sequences in [Table 4-1](#) and [Table 4-2](#) and add two external diodes as shown in [Figure 4-1](#). The first diode is a high-voltage diode across V_{PP} and V_{DD} where the anode of the diode is connected to V_{DD} and the cathode of the diode is connected to V_{PP} . Any low-current high-voltage diode such as a 1N4004 will be adequate. The second diode is a Schottky diode across V_{NN} and D_{GND} where the anode of the Schottky diode is connected to V_{NN} and the cathode is connected to D_{GND} . Any low-current Schottky diode such as a 1N5817 will be sufficient.

4.1.2 RECOMMENDED POWER-UP/POWER-DOWN SEQUENCE

The HV256 needs all power supplies to be fully up and all channels refreshed with $V_{SIG} = 0V$ to force all high-voltage outputs to 0V. Before that time, the high-voltage outputs may have temporary voltage excursions above or below GND level, depending on selected power-up sequence. To minimize the excursions, the V_{DD} and V_{NN} power supplies should be applied at the same time (or within a few nanoseconds). In addition, the suggested V_{PP} ramp-up speed should be 10 milliseconds or longer and the ramp-down should be 1 millisecond or longer.

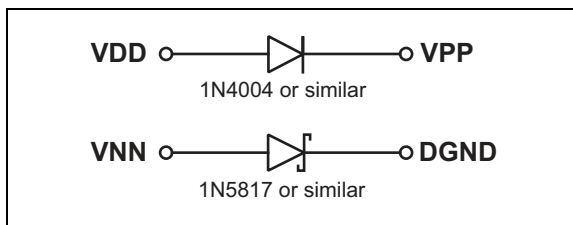

FIGURE 4-1: Diode Configuration.

TABLE 4-1: ACCEPTABLE POWER-UP SEQUENCES

Option 1		Option 2		Option 3	
Step	Description	Step	Description	Step	Description
1	V_{PP}	1	V_{NN}	1	V_{DD} and V_{NN}
2	V_{NN}	2	V_{DD}	2	Inputs
3	V_{DD}	3	V_{PP}	3	V_{PP}
4	Inputs and Anode	4	Inputs and Anode	4	Anode

TABLE 4-2: ACCEPTABLE POWER-DOWN SEQUENCES

Option 1		Option 2		Option 3	
Step	Description	Step	Description	Step	Description
1	Inputs and Anode	1	Inputs and Anode	1	Anode
2	V_{DD}	2	V_{PP}	2	V_{PP}
3	V_{NN}	3	V_{DD}	3	Inputs
4	V_{PP}	4	V_{NN}	4	V_{NN} and V_{DD}

HV256

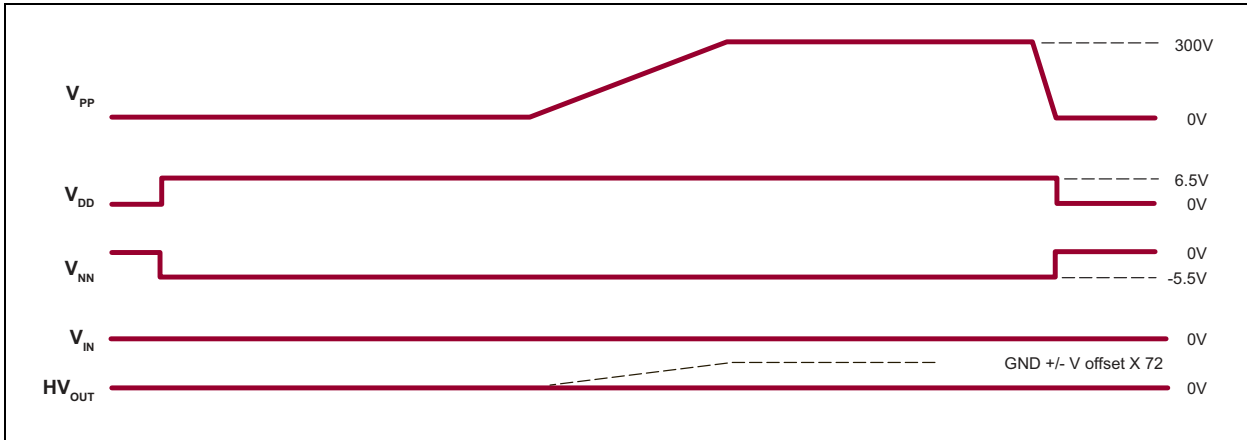

FIGURE 4-2: Recommended Power-up/Power-down Timing.

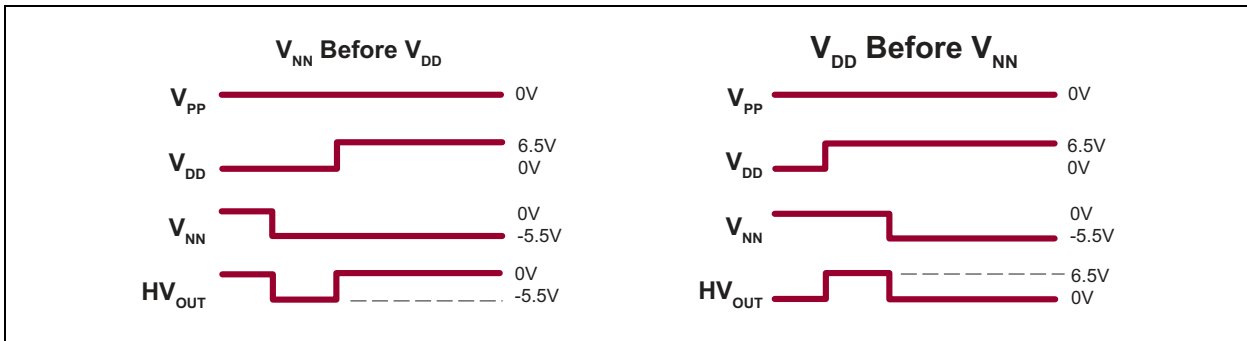

FIGURE 4-3: HV_{OUT} Level at Power-up.

4.2 R_{SINK}/R_{SOURCE}

The V_{DD_BYP} , V_{DD_BYP} and V_{NN_BYP} pins are internal high-impedance-current mirror gate nodes, brought out to maintain stable opamp biasing currents in noisy power supply environments. When $0.1\ \mu\text{F}/25\text{V}$ bypass capacitors are added from between V_{PP_BYP} and V_{PP} , between V_{DD_BYP} and V_{DD} , and between V_{NN_BYP} and V_{NN} , they will force the high-impedance gate nodes to follow the fluctuation of power lines. The expected voltages at the V_{DD_BYP} and V_{NN_BYP} pins are typically 1.5V from their respectful power supply. The expected voltage at V_{PP_BYP} is typically 3V below V_{PP} .

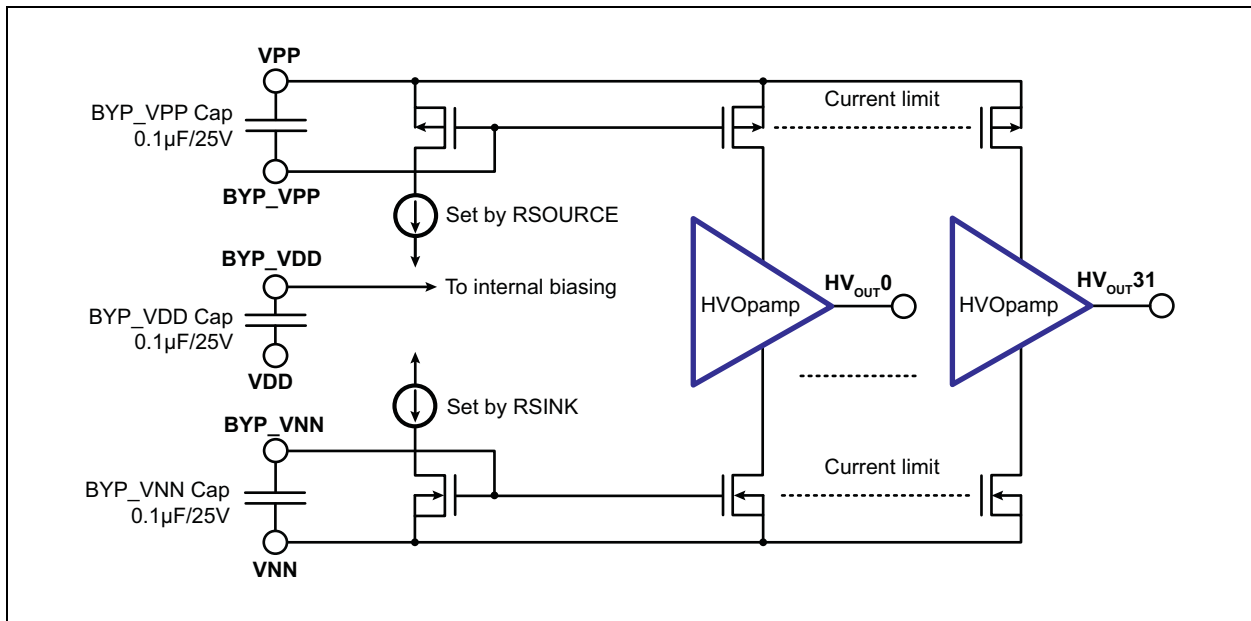
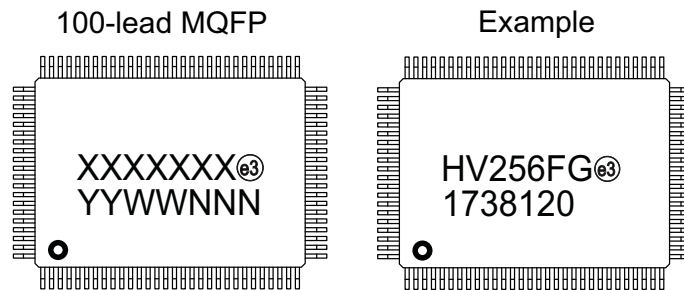

FIGURE 4-4: Internal Reference Current Diagram.

HV256

5.0 PACKAGE MARKING INFORMATION

5.1 Packaging Information



Legend:	XX...X	Product Code or Customer-specific information
	Y	Year code (last digit of calendar year)
	YY	Year code (last 2 digits of calendar year)
	WW	Week code (week of January 1 is week '01')
	NNN	Alphanumeric traceability code
	^(E3)	Pb-free JEDEC [®] designator for Matte Tin (Sn)
	*	This package is Pb-free. The Pb-free JEDEC designator ^(E3) can be found on the outer packaging for this package.
Note:	In the event the full Microchip part number cannot be marked on one line, it will be carried over to the next line, thus limiting the number of available characters for product code or customer-specific information. Package may or not include the corporate logo.	

100-Lead MQFP Package Outline (FG)

20.00x14.00mm body, 3.15mm height (max), 0.65mm pitch, 3.20mm footprint

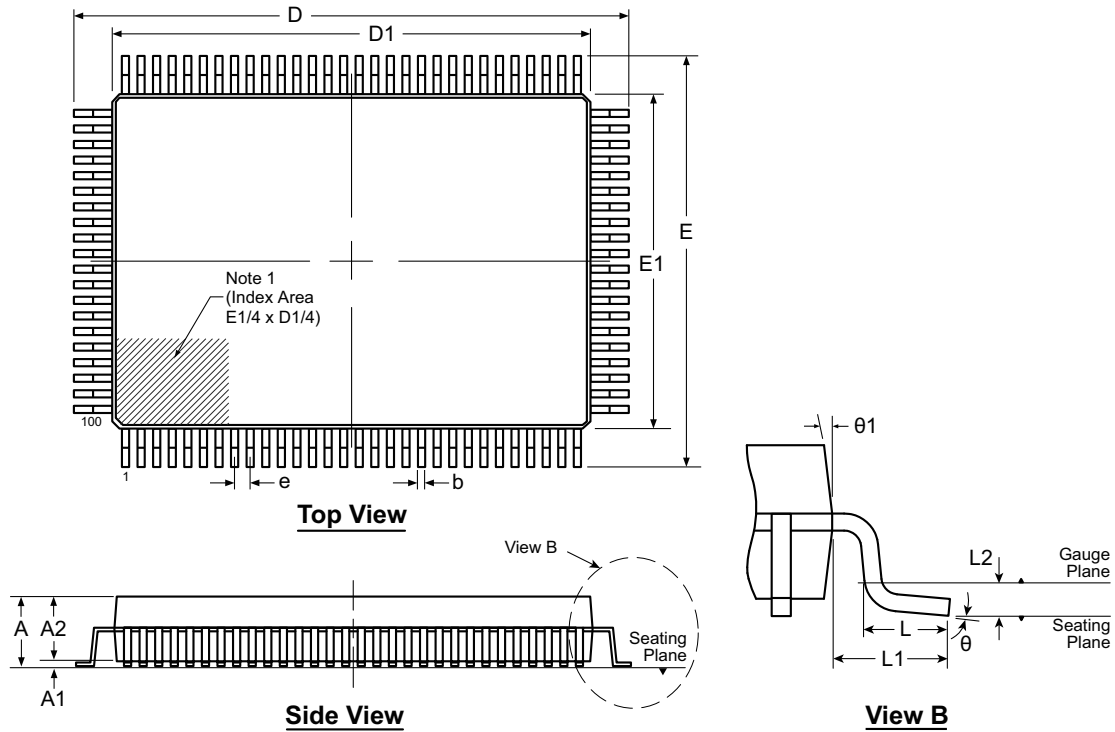

Note: For the most current package drawings, see the Microchip Packaging Specification at www.microchip.com/packaging.

Note:

1. A Pin 1 identifier must be located in the index area indicated. The Pin 1 identifier can be: a molded mark/identifier; an embedded metal marker; or a printed indicator.

Symbol	A	A1	A2	b	D	D1	E	E1	e	L	L1	L2	θ	$\theta 1$	
Dimension (mm)	MIN	2.50*	0.00	2.50	0.22	22.95*	19.80*	16.95*	13.80*	0.65 BSC	0.73	1.60 REF	0.25	0°	5°
	NOM	-	-	2.70	-	23.20	20.00	17.20	14.00		0.88		-	-	
	MAX	3.15	0.25	2.90	0.40	23.45*	20.20*	17.45*	14.20*		1.03		7°	16°	

JEDEC Registration MS-022, Variation GC-2, Issue B, Dec. 1996.

* This dimension is not specified in the JEDEC drawing.

Drawings are not to scale.

HV256

NOTES:

APPENDIX A: REVISION HISTORY

Revision B (December 2020)

- Updated [Pin Function Table](#).
- Removed Pad Configuration and Pad Coordinates from the [Pin Description](#) section.

Revision A (August 2017)

- Converted Supertex Doc# DSFP-HV256 to Microchip DS20005826B
- Changed the part marking format
- Made minor text changes throughout the document

HV256

NOTES:

PRODUCT IDENTIFICATION SYSTEM

To order or obtain information, e.g., on pricing or delivery, contact your local Microchip representative or sales office.

<u>PART NO.</u>	<u>XX</u>	-	<u>X</u>	-	<u>X</u>
Device	Package Options		Environmental		Media Type
Device:	HV256	=	32-Channel High-Voltage Amplifier Array		
Package:	FG	=	100-lead MQFP		
Environmental:	G	=	Lead (Pb)-free/RoHS-compliant Package		
Media Type:	(blank)	=	66/Tray for an FG Package		

Example:

a) HV256FG-G: 32-Channel High-Voltage Amplifier Array, 100-lead MQFP, 66/Tray

HV256

NOTES:

Note the following details of the code protection feature on Microchip devices:

- Microchip products meet the specifications contained in their particular Microchip Data Sheet.
- Microchip believes that its family of products is secure when used in the intended manner and under normal conditions.
- There are dishonest and possibly illegal methods being used in attempts to breach the code protection features of the Microchip devices. We believe that these methods require using the Microchip products in a manner outside the operating specifications contained in Microchip's Data Sheets. Attempts to breach these code protection features, most likely, cannot be accomplished without violating Microchip's intellectual property rights.
- Microchip is willing to work with any customer who is concerned about the integrity of its code.
- Neither Microchip nor any other semiconductor manufacturer can guarantee the security of its code. Code protection does not mean that we are guaranteeing the product is "unbreakable." Code protection is constantly evolving. We at Microchip are committed to continuously improving the code protection features of our products. Attempts to break Microchip's code protection feature may be a violation of the Digital Millennium Copyright Act. If such acts allow unauthorized access to your software or other copyrighted work, you may have a right to sue for relief under that Act.

Information contained in this publication is provided for the sole purpose of designing with and using Microchip products. Information regarding device applications and the like is provided only for your convenience and may be superseded by updates. It is your responsibility to ensure that your application meets with your specifications.

THIS INFORMATION IS PROVIDED BY MICROCHIP "AS IS". MICROCHIP MAKES NO REPRESENTATIONS OR WARRANTIES OF ANY KIND WHETHER EXPRESS OR IMPLIED, WRITTEN OR ORAL, STATUTORY OR OTHERWISE, RELATED TO THE INFORMATION INCLUDING BUT NOT LIMITED TO ANY IMPLIED WARRANTIES OF NON-INFRINGEMENT, MERCHANTABILITY, AND FITNESS FOR A PARTICULAR PURPOSE OR WARRANTIES RELATED TO ITS CONDITION, QUALITY, OR PERFORMANCE.

IN NO EVENT WILL MICROCHIP BE LIABLE FOR ANY INDIRECT, SPECIAL, PUNITIVE, INCIDENTAL OR CONSEQUENTIAL LOSS, DAMAGE, COST OR EXPENSE OF ANY KIND WHATSOEVER RELATED TO THE INFORMATION OR ITS USE, HOWEVER CAUSED, EVEN IF MICROCHIP HAS BEEN ADVISED OF THE POSSIBILITY OR THE DAMAGES ARE FORESEEABLE. TO THE FULLEST EXTENT ALLOWED BY LAW, MICROCHIP'S TOTAL LIABILITY ON ALL CLAIMS IN ANY WAY RELATED TO THE INFORMATION OR ITS USE WILL NOT EXCEED THE AMOUNT OF FEES, IF ANY, THAT YOU HAVE PAID DIRECTLY TO MICROCHIP FOR THE INFORMATION. Use of Microchip devices in life support and/or safety applications is entirely at the buyer's risk, and the buyer agrees to defend, indemnify and hold harmless Microchip from any and all damages, claims, suits, or expenses resulting from such use. No licenses are conveyed, implicitly or otherwise, under any Microchip intellectual property rights unless otherwise stated.

Trademarks

The Microchip name and logo, the Microchip logo, Adaptec, AnyRate, AVR, AVR logo, AVR Freaks, BesTime, BitCloud, chipKIT, chipKIT logo, CryptoMemory, CryptoRF, dsPIC, FlashFlex, flexPWR, HELDO, IGL00, JukeBlox, KeeLoq, Kleer, LANCheck, LinkMD, maXStylus, maXTouch, MediaLB, megaAVR, Microsemi, Microsemi logo, MOST, MOST logo, MPLAB, OptoLyzr, PackeTime, PIC, picoPower, PICSTART, PIC32 logo, PolarFire, Prochip Designer, QTouch, SAM-BA, SenGenuity, SpyNIC, SST, SST Logo, SuperFlash, Symmetricom, SyncServer, Tachyon, TimeSource, tinyAVR, UNI/O, Vectron, and XMEGA are registered trademarks of Microchip Technology Incorporated in the U.S.A. and other countries.

AgileSwitch, APT, ClockWorks, The Embedded Control Solutions Company, EtherSynch, FlashTec, Hyper Speed Control, HyperLight Load, IntelliMOS, Libero, motorBench, mTouch, Powermite 3, Precision Edge, ProASIC, ProASIC Plus, ProASIC Plus logo, Quiet-Wire, SmartFusion, SyncWorld, Temux, TimeCesium, TimeHub, TimePictra, TimeProvider, WinPath, and ZL are registered trademarks of Microchip Technology Incorporated in the U.S.A.

Adjacent Key Suppression, AKS, Analog-for-the-Digital Age, Any Capacitor, AnyIn, AnyOut, Augmented Switching, BlueSky, BodyCom, CodeGuard, CryptoAuthentication, CryptoAutomotive, CryptoCompanion, CryptoController, dsPICDEM, dsPICDEM.net, Dynamic Average Matching, DAM, ECAN, Espresso T1S, EtherGREEN, IdealBridge, In-Circuit Serial Programming, ICSP, INICnet, Intelligent Paralleling, Inter-Chip Connectivity, JitterBlocker, maxCrypto, maxView, memBrain, Mindi, MiWi, MPASM, MPF, MPLAB Certified logo, MPLIB, MPLINK, MultiTRAK, NetDetach, Omniscient Code Generation, PICDEM, PICDEM.net, PICkit, PICtail, PowerSmart, PureSilicon, QMatrix, REAL ICE, Ripple Blocker, RTAX, RTG4, SAM-ICE, Serial Quad I/O, simpleMAP, SimpliPHY, SmartBuffer, SMART-I.S., storClad, SQI, SuperSwitcher, SuperSwitcher II, Switchtec, SynchroPHY, Total Endurance, TSHARC, USBCheck, VariSense, VectorBlox, VeriPHY, ViewSpan, WiperLock, XpressConnect, and ZENA are trademarks of Microchip Technology Incorporated in the U.S.A. and other countries.

SQTP is a service mark of Microchip Technology Incorporated in the U.S.A.

The Adaptec logo, Frequency on Demand, Silicon Storage Technology, and Symmcom are registered trademarks of Microchip Technology Inc. in other countries.

GestIC is a registered trademark of Microchip Technology Germany II GmbH & Co. KG, a subsidiary of Microchip Technology Inc., in other countries.

All other trademarks mentioned herein are property of their respective companies.

© 2017-2020, Microchip Technology Incorporated, All Rights Reserved.

ISBN: 978-1-5224-7216-2

For information regarding Microchip's Quality Management Systems, please visit www.microchip.com/quality.



MICROCHIP

Worldwide Sales and Service

AMERICAS

Corporate Office
2355 West Chandler Blvd.
Chandler, AZ 85224-6199
Tel: 480-792-7200
Fax: 480-792-7277
Technical Support:
<http://www.microchip.com/support>
Web Address:
www.microchip.com

Atlanta
Duluth, GA
Tel: 678-957-9614
Fax: 678-957-1455

Austin, TX
Tel: 512-257-3370

Boston
Westborough, MA
Tel: 774-760-0087
Fax: 774-760-0088

Chicago
Itasca, IL
Tel: 630-285-0071
Fax: 630-285-0075

Dallas
Addison, TX
Tel: 972-818-7423
Fax: 972-818-2924

Detroit
Novi, MI
Tel: 248-848-4000

Houston, TX
Tel: 281-894-5983

Indianapolis
Noblesville, IN
Tel: 317-773-8323
Fax: 317-773-5453
Tel: 317-536-2380

Los Angeles
Mission Viejo, CA
Tel: 949-462-9523
Fax: 949-462-9608
Tel: 951-273-7800

Raleigh, NC
Tel: 919-844-7510

New York, NY
Tel: 631-435-6000

San Jose, CA
Tel: 408-735-9110
Tel: 408-436-4270

Canada - Toronto
Tel: 905-695-1980
Fax: 905-695-2078

ASIA/PACIFIC

Australia - Sydney
Tel: 61-2-9868-6733

China - Beijing
Tel: 86-10-8569-7000

China - Chengdu
Tel: 86-28-8665-5511

China - Chongqing
Tel: 86-23-8980-9588

China - Dongguan
Tel: 86-769-8702-9880

China - Guangzhou
Tel: 86-20-8755-8029

China - Hangzhou
Tel: 86-571-8792-8115

China - Hong Kong SAR
Tel: 852-2943-5100

China - Nanjing
Tel: 86-25-8473-2460

China - Qingdao
Tel: 86-532-8502-7355

China - Shanghai
Tel: 86-21-3326-8000

China - Shenyang
Tel: 86-24-2334-2829

China - Shenzhen
Tel: 86-755-8864-2200

China - Suzhou
Tel: 86-186-6233-1526

China - Wuhan
Tel: 86-27-5980-5300

China - Xian
Tel: 86-29-8833-7252

China - Xiamen
Tel: 86-592-2388138

China - Zhuhai
Tel: 86-756-3210040

ASIA/PACIFIC

India - Bangalore
Tel: 91-80-3090-4444

India - New Delhi
Tel: 91-11-4160-8631

India - Pune
Tel: 91-20-4121-0141

Japan - Osaka
Tel: 81-6-6152-7160

Japan - Tokyo
Tel: 81-3-6880-3770

Korea - Daegu
Tel: 82-53-744-4301

Korea - Seoul
Tel: 82-2-554-7200

Malaysia - Kuala Lumpur
Tel: 60-3-7651-7906

Malaysia - Penang
Tel: 60-4-227-8870

Philippines - Manila
Tel: 63-2-634-9065

Singapore
Tel: 65-6334-8870

Taiwan - Hsin Chu
Tel: 886-3-577-8366

Taiwan - Kaohsiung
Tel: 886-7-213-7830

Taiwan - Taipei
Tel: 886-2-2508-8600

Thailand - Bangkok
Tel: 66-2-694-1351

Vietnam - Ho Chi Minh
Tel: 84-28-5448-2100

EUROPE

Austria - Wels
Tel: 43-7242-2244-39
Fax: 43-7242-2244-393

Denmark - Copenhagen
Tel: 45-4485-5910
Fax: 45-4485-2829

Finland - Espoo
Tel: 358-9-4520-820

France - Paris
Tel: 33-1-69-53-63-20
Fax: 33-1-69-30-90-79

Germany - Garching
Tel: 49-8931-9700

Germany - Haan
Tel: 49-2129-3766400

Germany - Heilbronn
Tel: 49-7131-72400

Germany - Karlsruhe
Tel: 49-721-625370

Germany - Munich
Tel: 49-89-627-144-0
Fax: 49-89-627-144-44

Germany - Rosenheim
Tel: 49-8031-354-560

Israel - Ra'anana
Tel: 972-9-744-7705

Italy - Milan
Tel: 39-0331-742611
Fax: 39-0331-466781

Italy - Padova
Tel: 39-049-7625286

Netherlands - Drunen
Tel: 31-416-690399
Fax: 31-416-690340

Norway - Trondheim
Tel: 47-7288-4388

Poland - Warsaw
Tel: 48-22-3325737

Romania - Bucharest
Tel: 40-21-407-87-50

Spain - Madrid
Tel: 34-91-708-08-90
Fax: 34-91-708-08-91

Sweden - Gothenberg
Tel: 46-31-704-60-40

Sweden - Stockholm
Tel: 46-8-5090-4654

UK - Wokingham
Tel: 44-118-921-5800
Fax: 44-118-921-5820