

LOC	DIST	REVISIONS			
P	LTN	DESCRIPTION	DATE	DMN	APVD
E1		REVISED PER ECO-11-005033	21MAR2011	RK	HMR
F		REVISED PER ECO-14-000886	20FEB2014	JW	SH

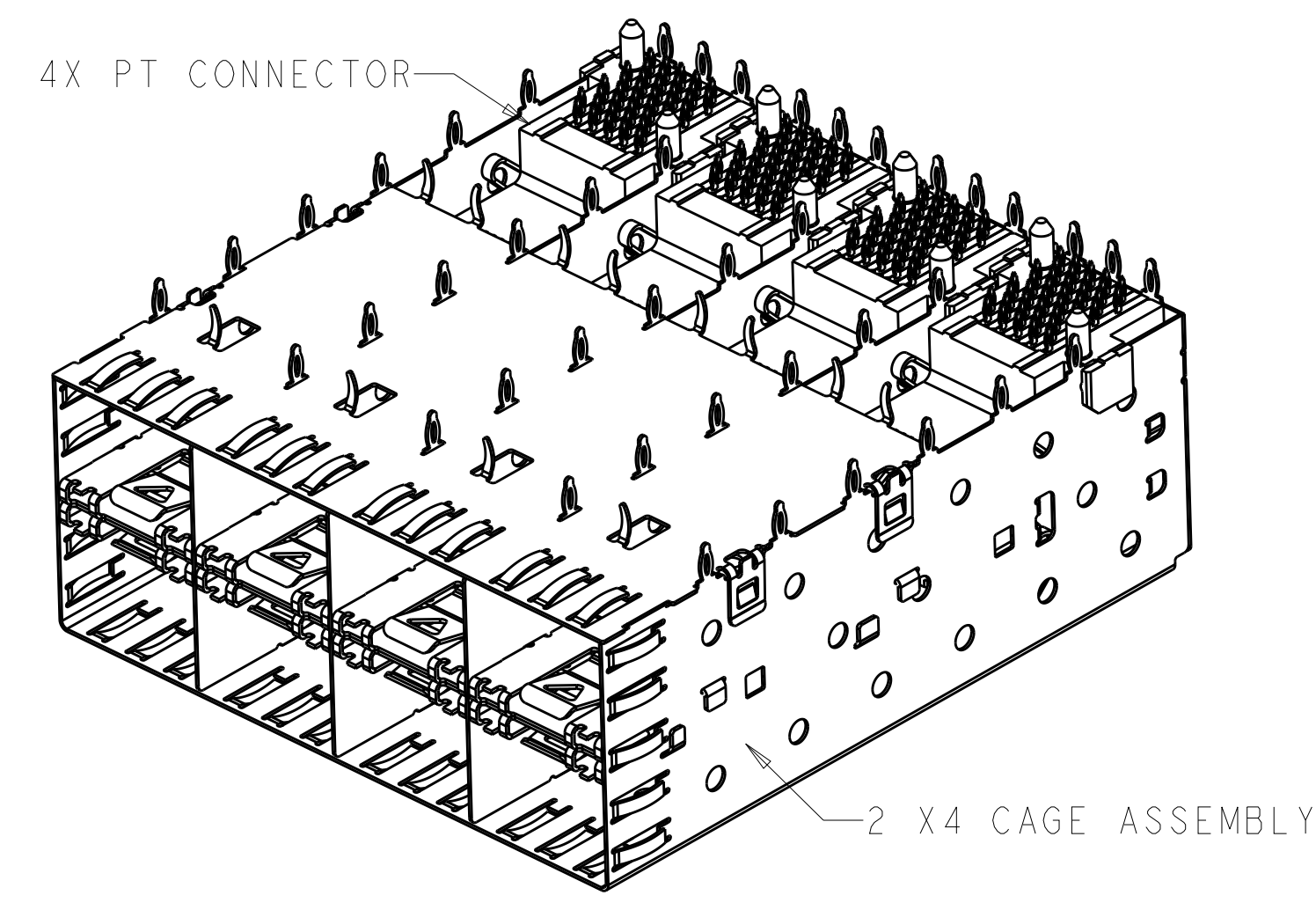
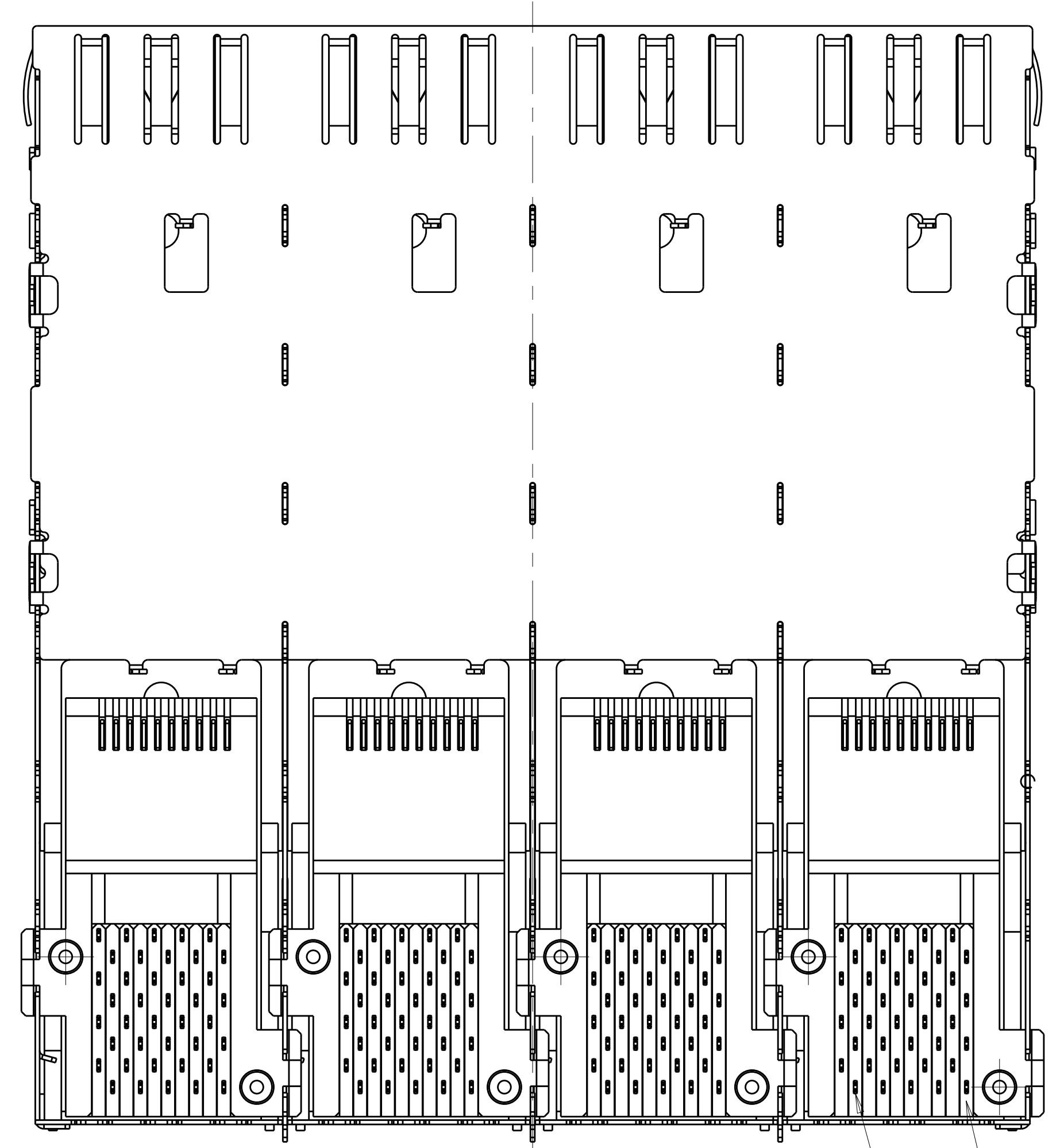
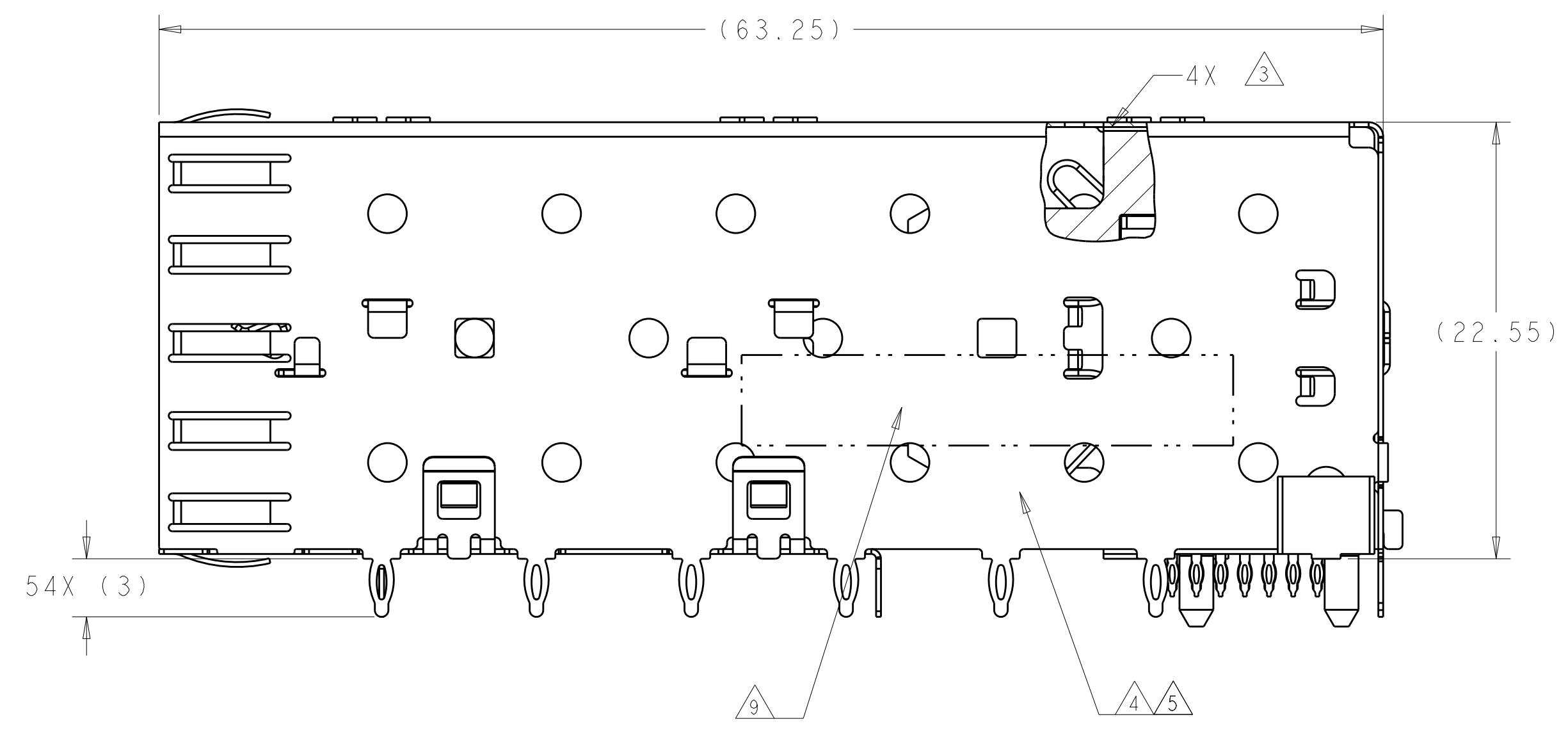
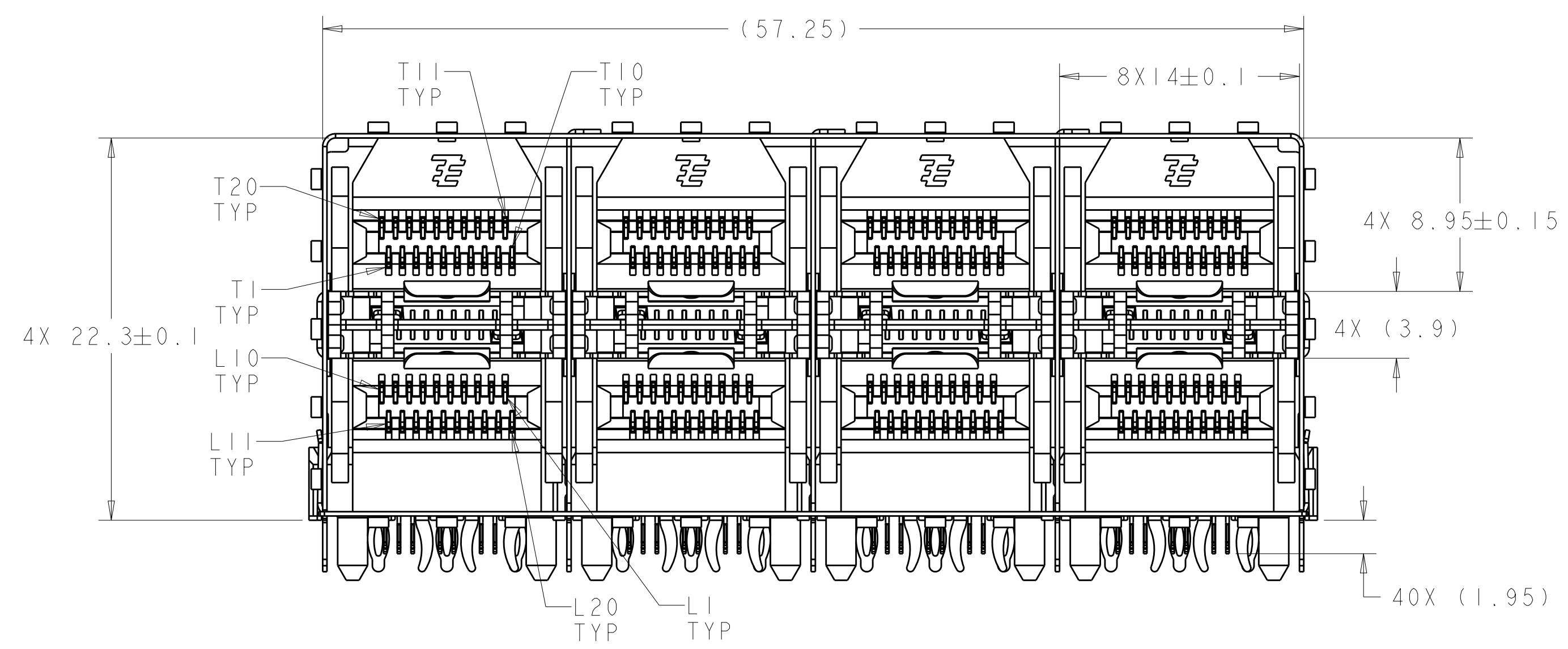

1658629-1  
SCALE 2:1

- △ DATUM AND BASIC DIMENSION TO BE DETERMINED BY CUSTOMER.
- △ INTERPRETATION OF DATUM REFERENCE FRAME IN ACCORDANCE WITH SECT 4.4.1.1 OF ASME Y14.5M-1994.
- △ TOP OF PT CONNECTOR TO BE 0-0.15 FROM INSIDE SURFACE OF CAGE.
- △ COPPER ALLOY.
- △ 1.25um MIN TIN PER ASTM B 545 OVER NICKEL FLASH PER QQ-N-290. NON-PLATED EDGES PERMISSIBLE.
- △ LCP, HIGH TEMPERATURE, UL 94V-0 RATED, BLACK.
- △ POLYESTER, UL 94V-0 RATED, BLACK.
- △ CONTACT MATING AREA: SURFACE TREATMENT OVER 0.76um MIN GOLD PER ASTM B 488 OVER 1.27um MIN NICKEL PER QQ-N-290. NEEDLE EYE: 1.25um MIN TIN PER ASTM B 545 OVER 1.27um MIN NICKEL PER QQ-N-290. REMAINDER OF CONTACT: 0.76um MIN NICKEL PER QQ-N-290.
- △ DATE CODE AND PART NUMBER IN APPROXIMATE AREA SHOWN.

1658629-1  
PART NUMBER

THIS DRAWING IS A CONTROLLED DOCUMENT.		DMN R. HENRY CHK J. KOPPENHEFFER APVD M. WALMSLEY	11APR03 23JAN04 23JAN04	TE Connectivity NAME CAGE AND PT CONNECTOR ASSEMBLY, 2x4, PRESS FIT, LOW PROFILE, SFP
DIMENSIONS:	TOLERANCES UNLESS OTHERWISE SPECIFIED:	PRODUCT SPEC	108-2161	
mm	0 PLC ± 1 PLC ±0.1 2 PLC ± 3 PLC ± 4 PLC ± ANGLES ±	APPLICATION SPEC	114-13103	SIZE A100779
MATERIAL	FINISH	WEIGHT		SCALE 4:1 SHEET 1 OF 3 REV F
CUSTOMER DRAWING		RESTRICTED TO		

LOC	DIST	REV	DATE	BY	APPV
ES	00				
REVISIONS					
DESCRIPTION			DATE	BY	APPV
SEE SHEET 1					

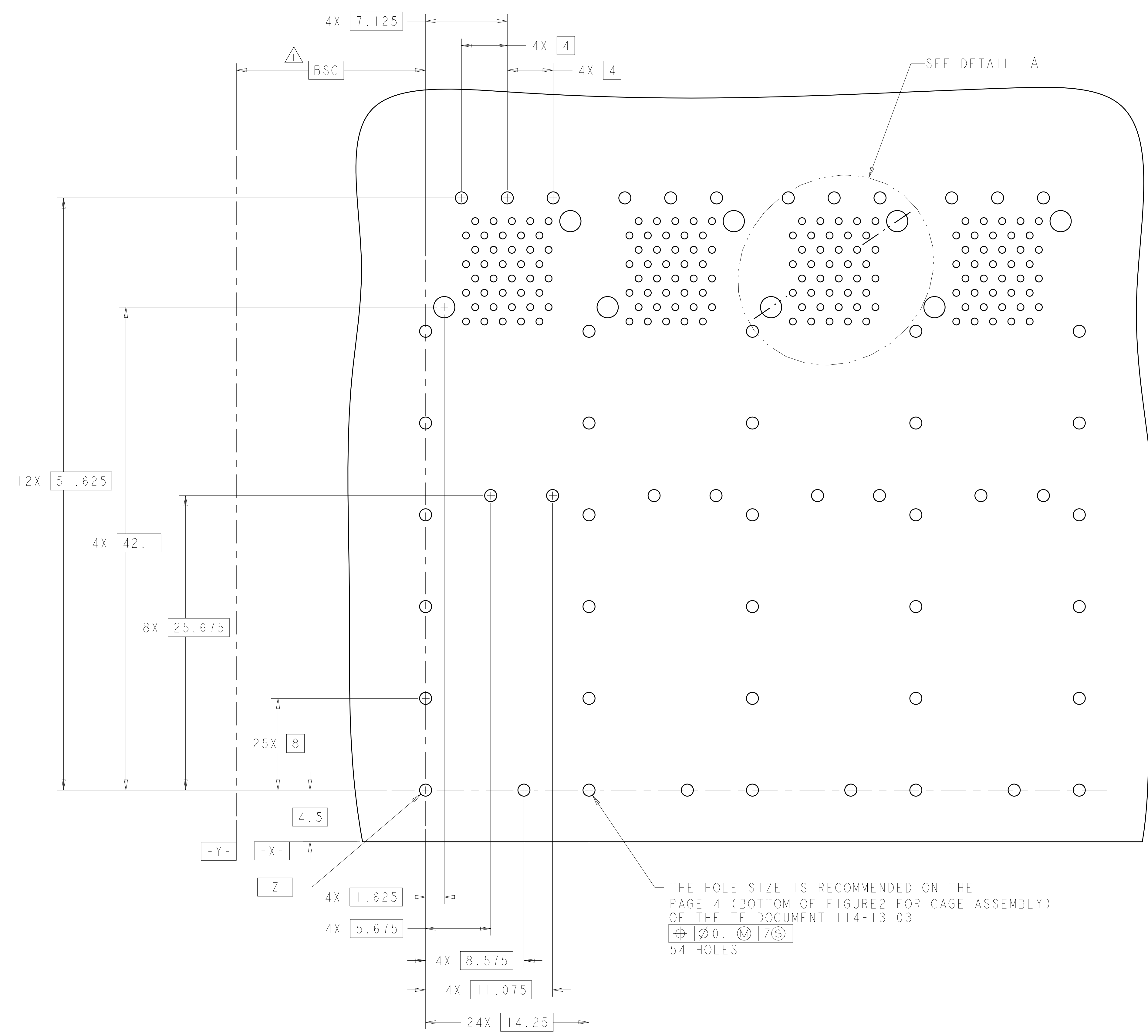

THE HOLE SIZE IS RECOMMENDED ON THE  
 PAGE 4 (BOTTOM OF FIGURE2 FOR CAGE ASSEMBLY)  
 OF THE TE DOCUMENT 114-13103  
 $\varnothing 0.10 \text{ (M)} | Z \text{ (S)}$   
 54 HOLES

RECOMMENDED PCB CONFIGURATION  
 SCALE 5:1

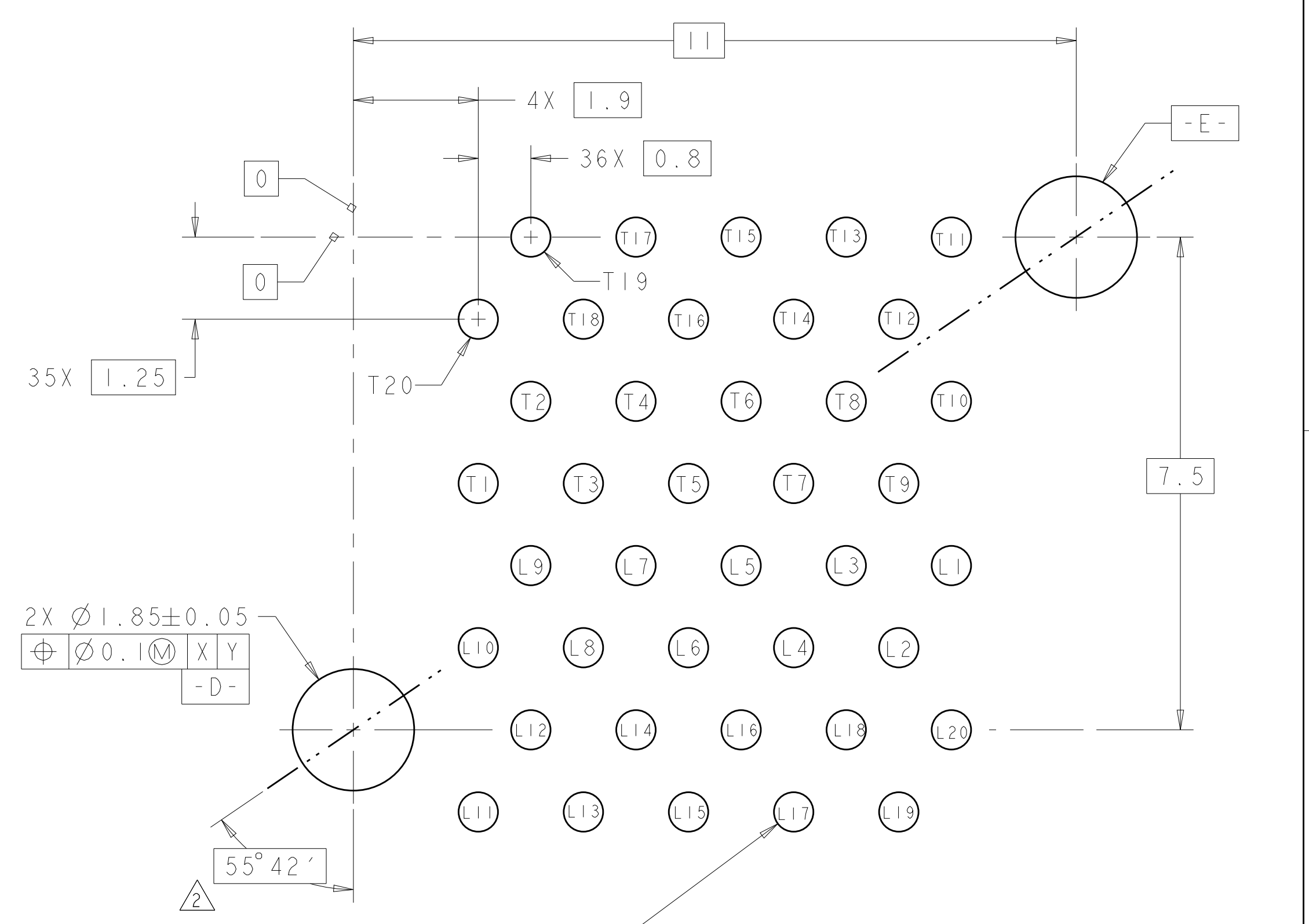

THE HOLE SIZE IS RECOMMENDED ON THE  
 PAGE 4 (TOP OF FIGURE2 FOR CONNECTOR)  
 OF THE TE DOCUMENT 114-13103  
 $\varnothing 0.08 \text{ (M)} | D \text{ (S)} | E \text{ (S)}$   
 40X4 HOLES

DETAIL A  
 SCALE 15:1

THIS DRAWING IS A CONTROLLED DOCUMENT.		OWN R. HENRY	11APR03	TE Connectivity
DIMENSIONS:		CHK J. KOPPENHEFFER	23JAN04	
mm	TOLERANCES UNLESS OTHERWISE SPECIFIED:	APV M. WALMSLEY	23JAN04	NAME CAGE AND PT CONNECTOR ASSEMBLY, 2x4, PRESS FIT, LOW PROFILE, SFP
0 PLC ± 2 PLC ±0.1 3 PLC ± 4 PLC ± ANGLES ±	MATERIAL FINISH	PRODUCT SPEC 108-2161 APPLICATION SPEC 114-13103 WEIGHT CUSTOMER DRAWING	SIZE A100779C=1658629	
SCALE 4:1				SHEET 2 OF 3 REV F

LOC		DIST		REVISIONS			
ES	00	P	LTN	DESCRIPTION	DATE	DWN	APVD
		-		SEE SHEET 1			

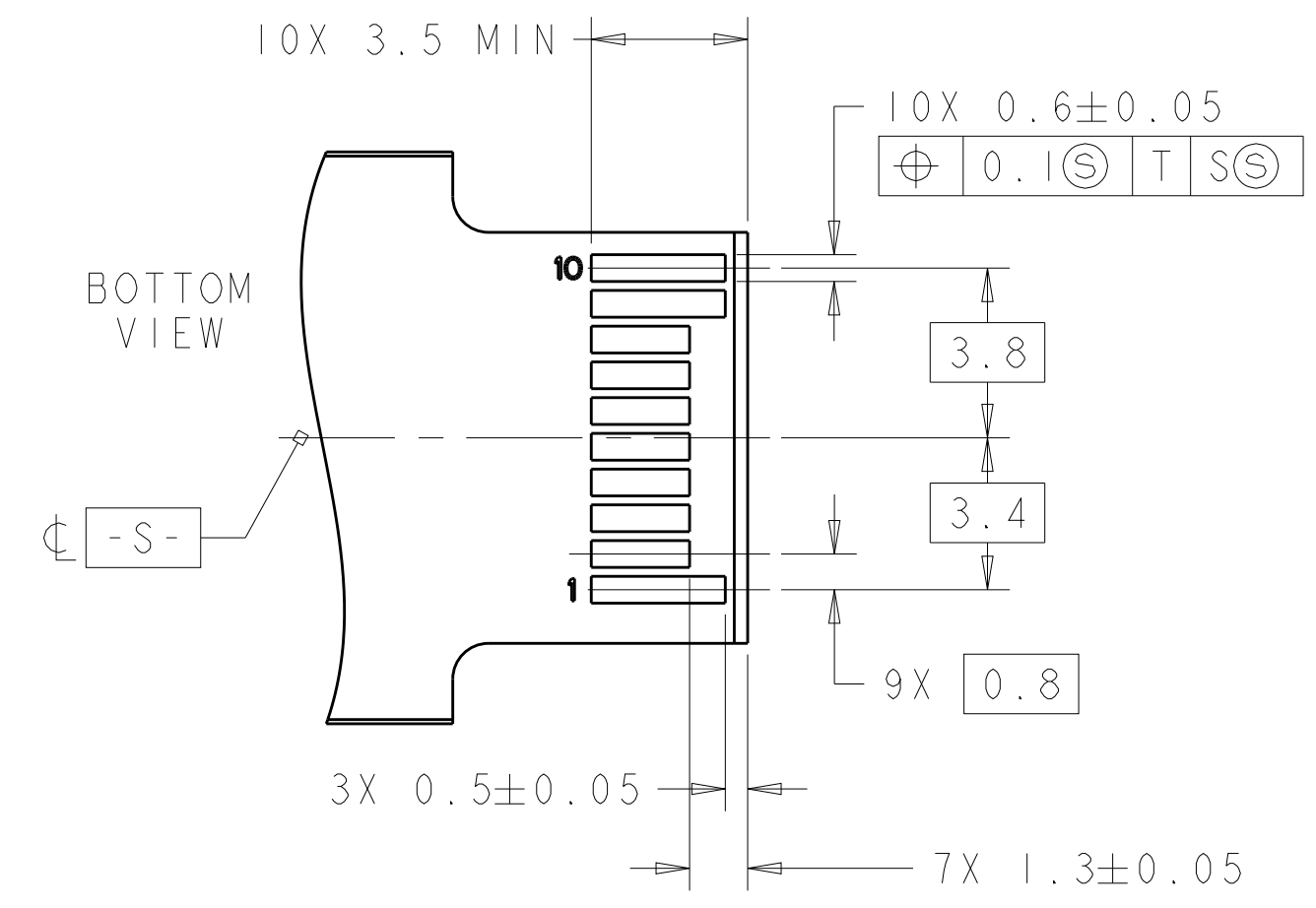
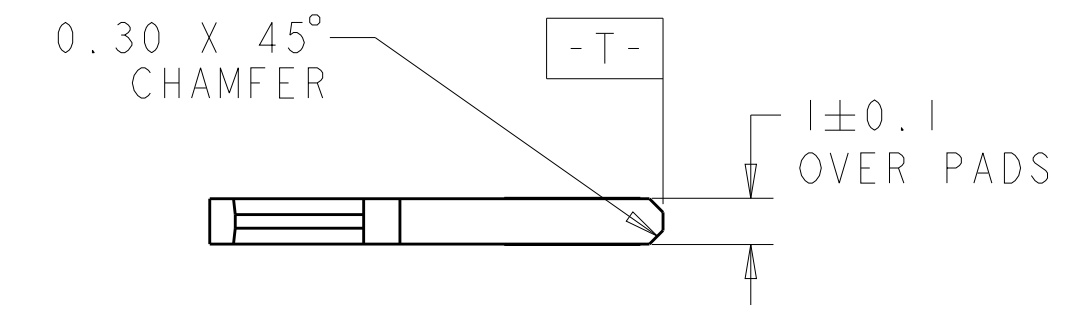
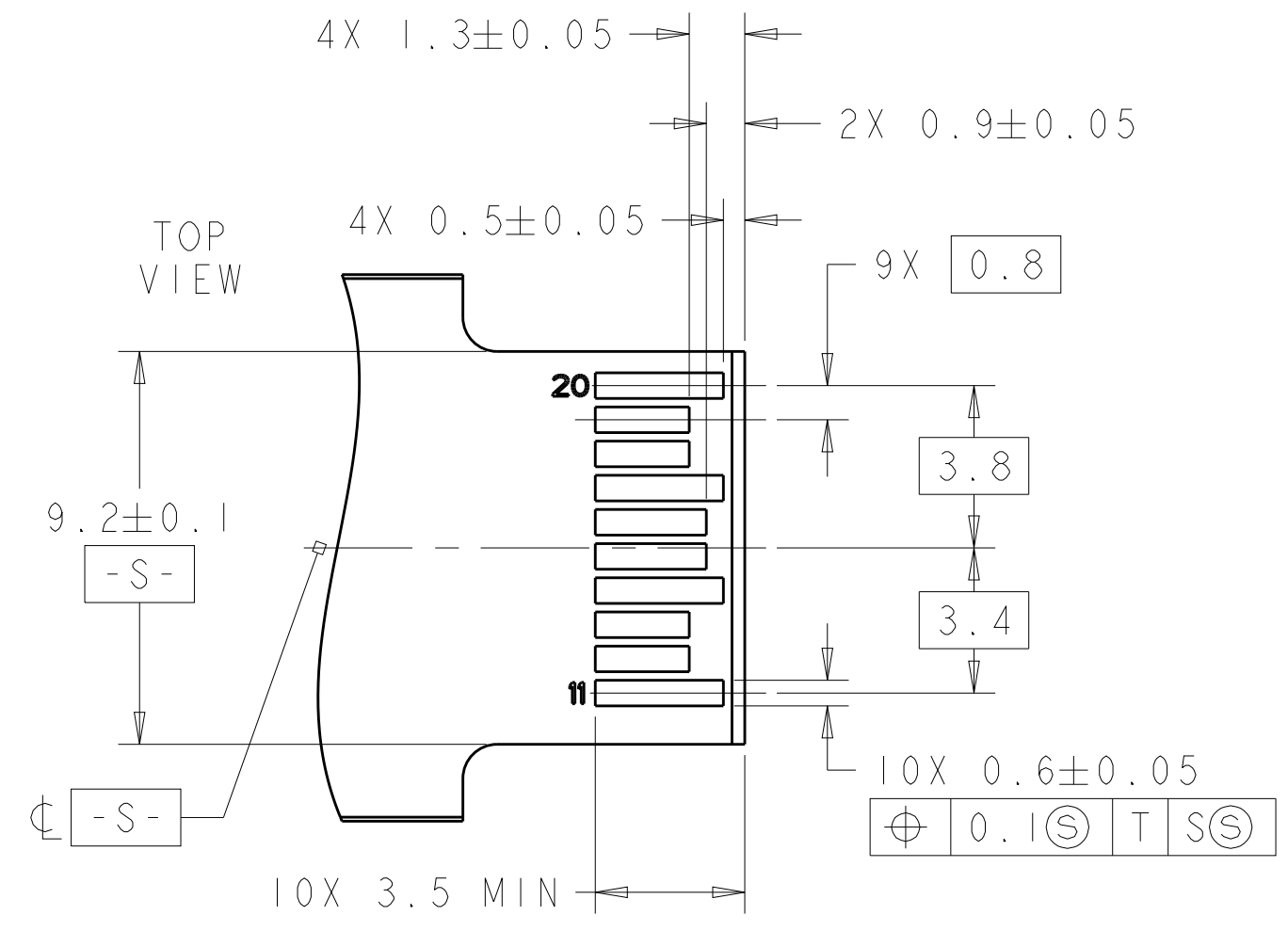

RECOMMENDED LAYOUT FOR  
 MATING TRANSCEIVER PCB  
 SCALE 6:1

THIS DRAWING IS A CONTROLLED DOCUMENT.		DWN R. HENRY	17APR03	 TE Connectivity
DIMENSIONS: mm		CHK J. KOPPENHEFFER	23JAN04	
TOLERANCES UNLESS OTHERWISE SPECIFIED:		APVD M. WALMSLEY	23JAN04	NAME CAGE AND PT CONNECTOR ASSEMBLY, 2x4, PRESS FIT, LOW PROFILE, SFP
0 PLC ± 1 PLC ± 2 PLC ±0.1 3 PLC ± 4 PLC ± ANGLES ±		PRODUCT SPEC 108-2161	APPLICATION SPEC 114-13103	SIZE A100779
MATERIAL		FINISH	WEIGHT	RESTRICTED TO C=1658629
		CUSTOMER DRAWING		SCALE 1:1 SHEET 3 OF 3 REV F