

MATERIAL

Transparent polyamide based (PA-T) technopolymer. Avoid contact with alcohol or detergents containing alcohol.

CIRCLE FOR OIL LEVEL CHECK

Delimited by a small red coloured externally tampoprinted circle. Tampoprinting resistant to oils with additives, greases, alkali and white spirit; resistant to abrasions under normal working conditions. Avoid contact with solvents, alcohol or detergents containing alcohol.

PACKING RING

NBR synthetic rubber.

MAXIMUM CONTINUOUS WORKING TEMPERATURE

100°C.

ACCESSORIES ON REQUEST

Brass nut type GH. (see page 1746) for fitting to reservoirs with wall thickness smaller than 5 mm.

TECHNICAL DATA

The tightening torque indicated in the table guarantees an optimal tightness, keeping the packing ring in the correct position.

NOTE

For use with other fluids with special additives, please contact ELESA Sales Department.



ELESA Original design

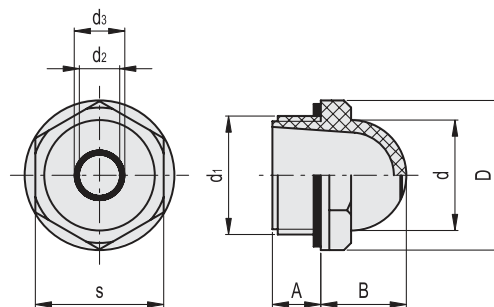

BSP

METRIC

Code	Description	d1	A	B	D	d	d2	d3	s	Tightening torque [Nm]	⚖️
10906	HCFE.15/C-1/2	G 1/2	10.5	16	26	19	6	7	22	4+6	5
11006	HCFE.20/C-3/4	G 3/4	10.5	19.5	31.5	25	11	12	27	6+8	8
11106	HCFE.24/C-1	G 1	11	24	42	31	14	15	36	8+10	18

- 1
- 2
- 3
- 4
- 5
- 6
- 7
- 8
- 9
- 10
- 11
- 12
- 13
- 14
- 15
- 16
- 17
- 18

Accessories for hydraulic systems