

Recommended PCB Layout
as viewed from component side

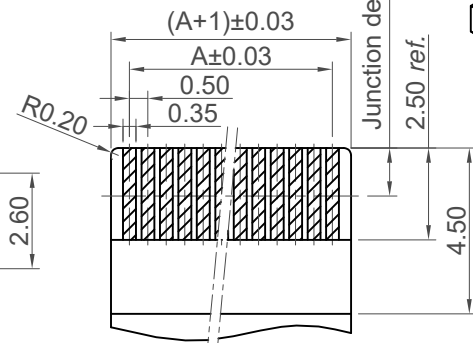

Recommended FFC/FPC Dimensions
Thickness: 0.30±0.03

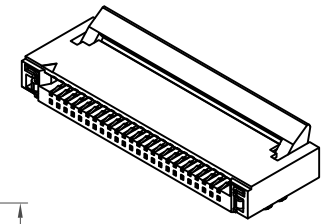

No. of Contacts	Dimensions		
	A	B	C
* 4	1.50	5.50	2.55
5	2.00	6.00	3.05
* 6	2.50	6.50	3.55
7	3.00	7.00	4.05
* 8	3.50	7.50	4.55
* 9	4.00	8.00	5.05
* 10	4.50	8.50	5.55
11	5.00	9.00	6.05
* 12	5.50	9.50	6.55
* 13	6.00	10.00	7.05
* 14	6.50	10.50	7.55
* 15	7.00	11.00	8.05
* 16	7.50	11.50	8.55
17	8.00	12.00	9.05
* 18	8.50	12.50	9.55
19	9.00	13.00	10.05
* 20	9.50	13.50	10.55
21	10.00	14.00	11.05
* 22	10.50	14.50	11.55
23	11.00	15.00	12.05
* 24	11.50	15.50	12.55
* 25	12.00	16.00	13.05
* 26	12.50	16.50	13.55
27	13.00	17.00	14.05
* 28	13.50	17.50	14.55
29	14.00	18.00	15.05
* 30	14.50	18.50	15.55
31	15.00	19.00	16.05
* 32	15.50	19.50	16.55
33	16.00	20.00	17.05
* 34	16.50	20.50	17.55
35	17.00	21.00	18.05
* 36	17.50	21.50	18.55
37	18.00	22.00	19.05
38	18.50	22.50	19.55
39	19.00	23.00	20.05
* 40	19.50	23.50	20.55

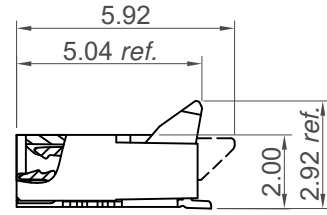
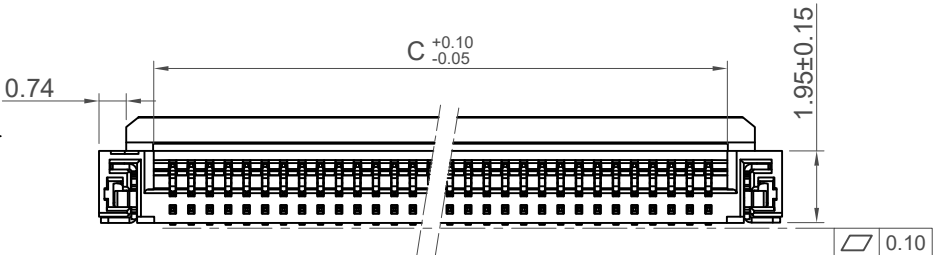

Specification:

Material:
 Housing Material: LCP, UL 94V-0, Natural
 Actuator: PA, UL 94V-0, Black
 Contact: Phosphor Bronze
 Fitting Nail: Brass

Plating:
 Contact: Gold Flash over all
 Fitting Nail: Matte Tin Plating over Nickel

Electrical:
 Voltage Rating (Max.): 50V AC/DC
 Current Rating (Max.): 0.4A AC/DC
 Dielectric Strength: 250V AC for 1 minute
 Insulation Resistance: 50 MΩ Min.
 Contact Resistance: 40 mΩ Max.

Mechanical & Environmental
 Durability: 20 Cycles
 Operating Temperature: -25°C to +85°C
 Solder Profile:
 Peak Temp 260°C (+0/-5°C) max. (5 seconds)

* = Tooled Parts
 Please contact GCT for non-tooled parts

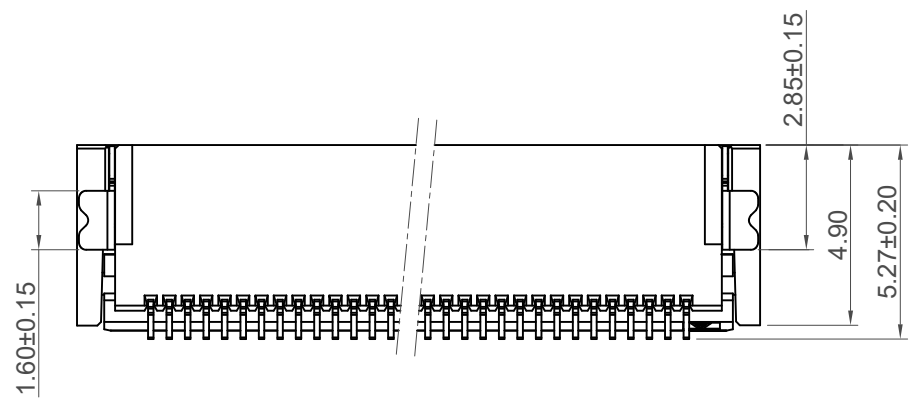

Ordering Grid
FFC2B27-XX-G Request Samples and Quotation
 No. of Contacts: 04 - 40 (see dimension table)
 Contact Plating: G = Gold Flash over all

Part Number		Product Description	
FFC2B27		FPC 0.5mm Pitch Side Entry, Dual Contact, SMT, Height=2.0mm, Back Flip	
Drawing Date		8th May 2019	
By	CC	Tolerances (Except as Noted)	Units:
Detail	Drawing Release	Length X.X ± 0.20 X.XX ± 0.10 X.XXX ± 0.05	Angle X.X° ± 2° X.XX° ± 1° X.XXX° ± 0.5°
Revision	A5	Metric (mm)	
Date	23/06/21		

GCT
www.gct.co

This drawing is confidential and copyright of Global Connector Technology, Ltd (GCT). This drawing must not be copied or disclosed without written consent. E & OE

Not to Scale	Drawn By CC	Sheet No. 1/2
--------------	----------------	------------------

H
G
F
E
D
C
B
A

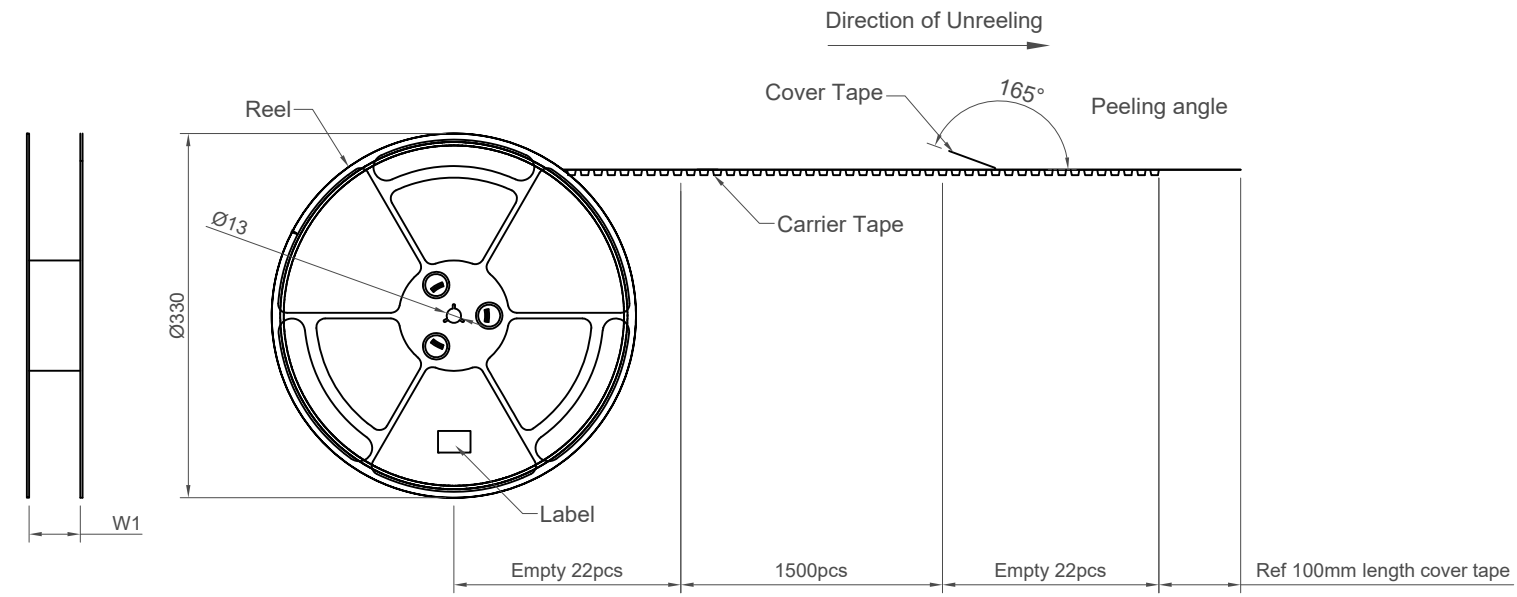

NOTES:
 1.Number of Connectors:
 1500 Pcs/Reel
 2.Material
 Carrier Tape:PE

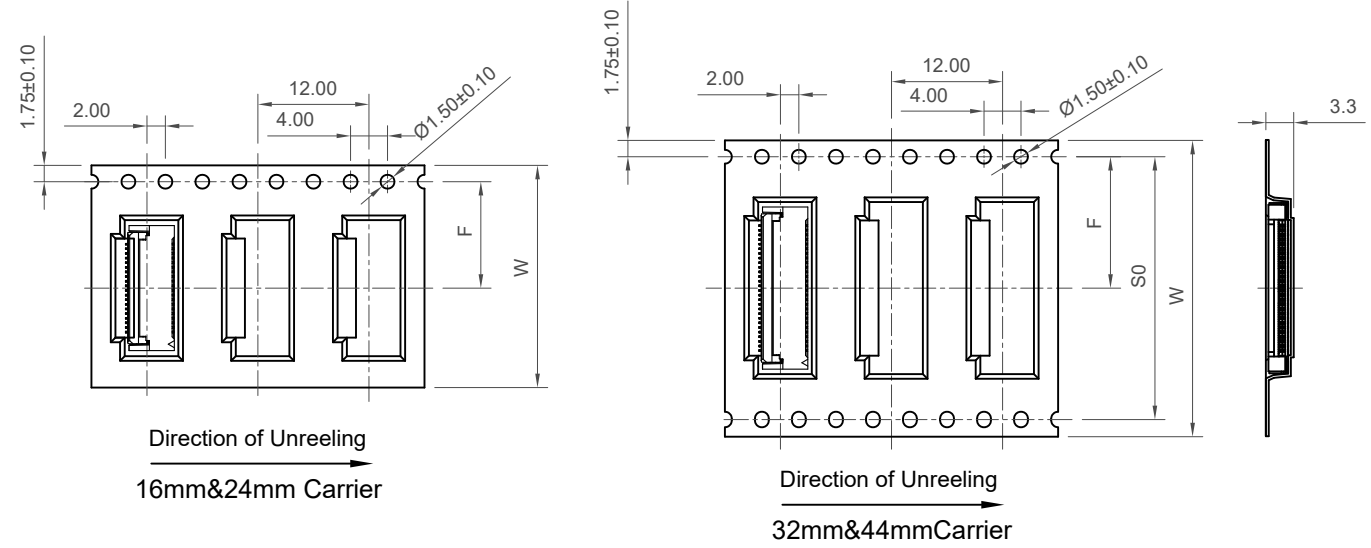

No. of Contacts	Dimensions			
	W	W1	F	S0
4 ~ 6	16	16.4	7.5±0.10	/
8 ~ 24	24	24.4	11.5±0.10	/
25 ~ 34	32	32.4	14.2±0.10	28.4±0.10
36 ~ 40	44	44.4	20.2±0.15	40.4±0.10

Part Number		Product Description	
FFC2B27		FPC 0.5mm Pitch Side Entry, Dual Contact, SMT, Height=2.0mm, Back Flip	
Drawing Date		8th May 2019	
By	CC	Tolerances (Except as Noted)	Units:
Detail	Drawing Release	Length	Metric (mm)
Revision	A5	X.X ± 0.30	X.X° ± 5°
Date	23/06/21	X.XX ± 0.20	X.XX° ± 2°
		X.XXX ± 0.10	X.XXX° ± 1°



This drawing is confidential and copyright of Global Connector Technology, Ltd (GCT). This drawing must not be copied or disclosed without written consent. E & OE



Not to Scale	Drawn By CC	Sheet No. 2/2
--------------	-------------	---------------

1 2 3 4 5 6 7 8