



Ultrasonic sensor module USSM1.0 PLUS-FS

with built-in ASIC for front chassis mounting

Series/Type:	Prototype sample
Ordering code:	Z25000Z2910Z001Z23
Date:	2023-03-01
Version:	1.0

Preliminary data
Table of Contents

Introduction.....	3
Highlights.....	3
Potential applications.....	3
Features	3
Technical specification.....	5
Dimensional data.....	5
Dimensional drawings.....	6
Pin configuration.....	7
Electrical characteristics	7
Acoustic operating characteristics	7
Functional description.....	10
Ultrasonic distance measurement.....	10
IO Interface and parametrization	11
Signal processing	11
Status information.....	11
Recommended mounting.....	12
Mounting with threaded locking nut for chassis thicknesses up to 4 mm.....	12
Mounting with snap hook	13
Application specific support.....	17
Cautions and warnings	17
Display of ordering codes for TDK electronics products	17

Preliminary data

Introduction

Highlights

The USSM1.0 PLUS-FS is a versatile and reliable ultrasonic Time-of-Flight (ToF) range sensor which offers a user-friendly all-in-one package that already includes the driver, providing advanced ultrasonic signal processing using a high-end application-specific integrated circuit chip (ASIC). It allows custom-specific parametrization and provides reliable signal readings through its interface.



TDK's USSM1.0 PLUS-FS is a front chassis mounting sensor with an integrated socket connector. It supports mounting with a threaded locking nut and via snap hooks. The sensor is dust and water resistant on the front. With an optional flat gasket, a water and dust protected seal can be easily achieved towards the chassis in which it is installed. The sensor works in a wide range of light conditions, including full sunlight, and provides an accurate range of measurements independent of the target's color and optical transparency. This and its robust sensor housing makes the sensor ideal for many outdoor applications. The sensor's Field-of-View (FoV) can be customized and enables simultaneous range measurements to multiple objects in the FoV. Several algorithms can further process the range information for a variety of use cases in a wide range of applications.

The USSM1.0 PLUS-FS is a pulse-echo product intended for range-finding and presence- detection applications, using a single sensor for the transmission and reception of ultrasonic pulses (solo mode). For close-range detection down to 4 cm, two or more USSM1.0 PLUS-FS can be used in the so-called pitch-and-catch mode where one sensor is the sender, and the others act as receiver for the ultrasonic pulse.

Potential applications

- Automated guided vehicles and automated mobile robots
- Obstacle avoidance in air
- Obstacle detection and proximity/presence sensing
- Distance measurement in air
- Level measurement in air

Features

- Robust, fast, and accurate range finding
 - Std. operating range from 4 cm¹ / 18 cm to 2 m
 - Water/dust protected chassis integration up to IP65/67 (EN60529)
 - Sample rate up to 50 samples/sec
 - Programmable modes optimized for medium and short-range sensing
 - Digitally adjustable detection characteristic

¹ In pitch-and-catch mode; requires two sensors in which one is the emitter and the second the receiver

Preliminary data

- Symmetric directivity of $\pm 35^\circ$ ²
 - Multi-object detection and differentiation
 - Works in a wide range of lighting conditions, including full sunlight to complete darkness
 - Detects transparent surfaces, insensitive to object color and density
 - Operating temperature range -40 to 85 °C
- Easy to integrate
- Integrated socket connector
 - For front chassis mounting applications
 - Integrated slots for snap-hook mounting
 - Built-in thread for direct chassis mounting with locking nut
 - Single sensor for send and receive (solo mode) or pitch-and-catch mode (split emitter and receiver operation) for very close-range applications
 - Single 12 V supply to drive and process piezo signals results in improved acoustic and EMI noise immunity
 - Self-diagnostic functions available for monitoring sensor status

² -6 dB sound pressure level, circular beam

Preliminary data
Technical specification
Dimensional data

Parameter	Symbol	Unit	Typical
Outer diameter	D1	mm	22
Thread size	D2	mm	M19x1
Width of locking surfaces	W1	mm	17.4
Height	H1	mm	10.5
Thread length	H3	mm	8.3
Dome height	H4	mm	2.2
Snap-hook shoulder height	H5	mm	6.3
Snap-hook slit height	H6	mm	2
Snap-hook slit width	W2	mm	3.8
Snap-hook slit depth	T1	mm	0.5
Connector height	C1	mm	1.9 ±0.5
Connector width	C2	mm	5
Connector depth	C3	mm	2.9
Connector offset	O1	mm	2
Connector pitch	P1	mm	1
Maximum chassis thickness for mounting with locking nut	T2	mm	4
Weight (without locking nut and gasket)	X	g	3.7
Recommended mounting torque for locking nut	M1	Nm	2
Maximum mounting torque for locking nut	M1max	Nm	5

Preliminary data

Dimensional drawings

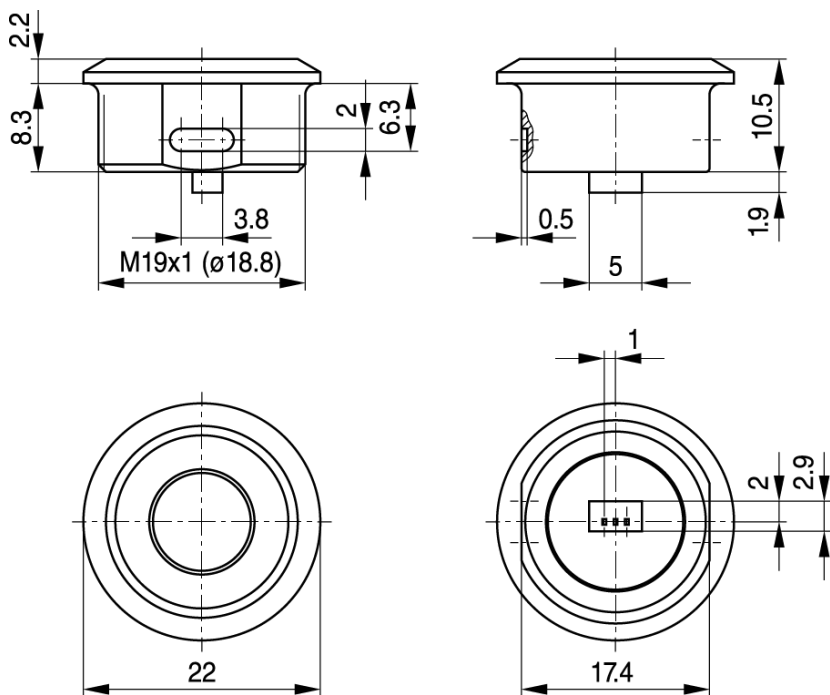

TPT2041-F

Drawings not to scale
Dimensions in mm

Preliminary data
Pin configuration

Pin	Name	Description
1	VSUP	Power supply connection
2	IO	Digital communication line
3	GND	Electric ground connection

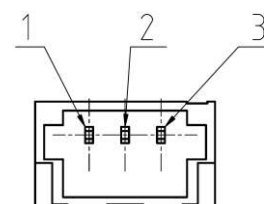
Electrical characteristics

Parameter	Symbol	Unit	Typical
Supply voltage	VSUP	V	12
Current consumption	I	mA	5.5
Power down mode	I	mA	< 1
Communication interface ³	proprietary bidirectional IO (3-pin), point to point architecture		

Acoustic operating characteristics ⁴

#	Parameter	Symbol	Unit	Typical
1	Minimal measuring distance in solo mode ⁵	DMIN	mm	180
2	Minimal measuring distance in pitch-and-catch mode ⁶	DMIN	mm	40
3	Maximum measuring distance	DMAX	mm	2000
4	Directivity of emitted acoustic signal ⁷	α	degree	± 35
5	Detection field of view ⁸	δ MIN δ MAX	degree	± 10 ± 45
6	Acoustic operating frequency	f	kHz	74.5

All listed parameter values use the standard ASIC parametrization (except #5). These parameters (except #4 and 6) can be modified according to application needs within the ASIC boundaries.

³ The IO line is not equipped with a pull-up resistor.

⁴ Overall system performance depends on mounting conditions

⁵ Evaluated based on test target: cylindrical pole, 75 mm diameter, 1 m height, standard conditions for temperature and humidity

⁶ Evaluated based on test target: cylindrical pole, 75 mm diameter, 1 m height, standard conditions for temperature and humidity

⁷ -6 dB sound pressure level relative to forward direction, circular beam

⁸ The detection field of view depends strongly on the threshold settings and on the target size and acoustic properties.

Preliminary data

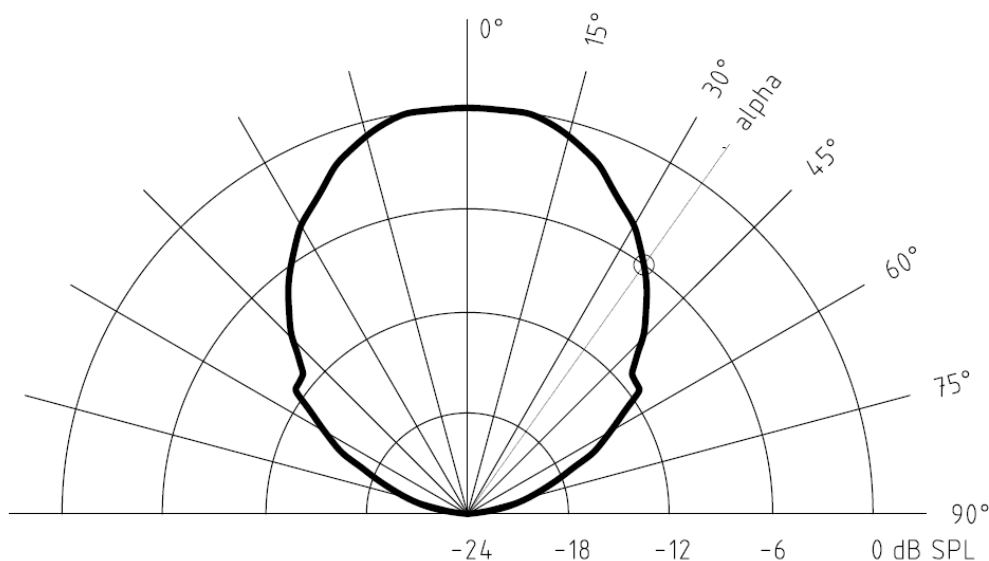

Typical directivity pattern (SPL relative to forward direction)

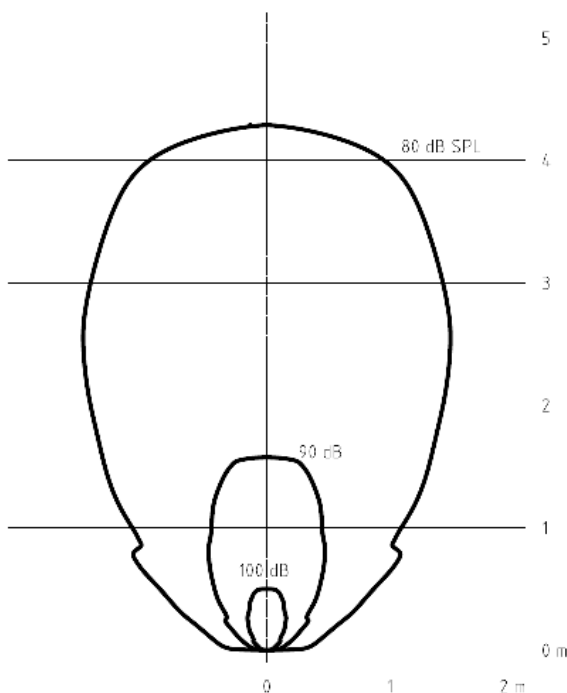

Typical acoustic emission curve ⁹

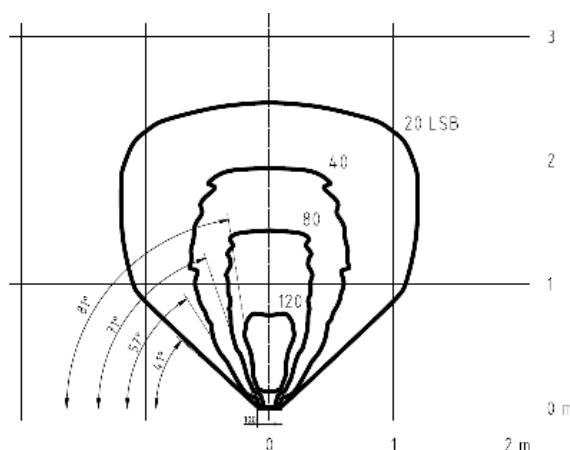

Detection curve in solo mode (reported echo amplitude value) ¹⁰

⁹ Under ideal conditions and with default settings

¹⁰ Only valid for ISO-Pole target (75 mm PVC cylinder) under ideal conditions and with default settings. In pitch-and-catch mode these curves vary strongly by the distance between sender and receiver and the cross angle.

Preliminary data
Compliant protection ratings

The stated protection ratings apply for the sensor front, only if the sensor is mounted into a chassis according to the mounting recommendations defined in this document. The rear side of the sensor must be reasonably dust free, dry, and non-corrosive conditions to ensure proper electric cable connection and proper functionality.

#	Test	According to	Effective against
1	IP6X	EN 60529:1991	No ingress of dust; complete protection against contact (dust-tight). A vacuum must be applied. Test duration of up to 8 hours based on airflow. Talcum powder, diameter of talcum particle 0 to 75 µm.
2	IP6kX	ISO20653:2013	No ingress of dust; complete protection against contact (dust-tight). Test duration 6 s movement of air-dust mixture at intervals of 15 min, 20 cycles. A2 (Arizona dust) according to ISO 12103-1.
3	IPX5	EN 60529:1991 ISO 20653:2013	Water jet projected by a nozzle (6.3 mm) against enclosure from any direction. 3 min duration at flowrate 12.5 l/min ±5%, water temperature 20 ±5 °C and at a distance of 2.5 to 3.0 m.
4	IPX7	EN 60529:1991 ISO 20653:2013	Immersion in water, up to 1 meter depth. Duration 30 min at 20 ±5 °C water temperature.

Absolute maximum ratings

#	Description	Condition	Symbol	Min	Max	Unit
1	Supply voltage		VSUP	-0.3	36	V
2	Supply voltage	t < 500 ms	VSUP	-0.3	40	V
3	Voltage at pin IO		VIO	-0.3	36	V
4	Voltage at pin IO	t < 500 ms	VSUP	-0.3	40	V
5	Measurement rate ¹¹		SMAX		50	Hz
6	Storage temperature		TS	-25	45	°C
7	Operation temperature		TO	-40	85	°C

¹¹ Number of times per seconds the result of a ToF measurement can be provided on the digital IO line.

Preliminary data

Functional description

Ultrasonic distance measurement

In a Time-of-Flight (ToF) sensor like the USSM1.0 PLUS-FS, the time difference T between a triggered acoustic burst and its reflected echo from an object is measured. The relationship $L=c*T/2$, where c is the velocity of sound, allows to directly calculate the distance L from the reflection time difference T .

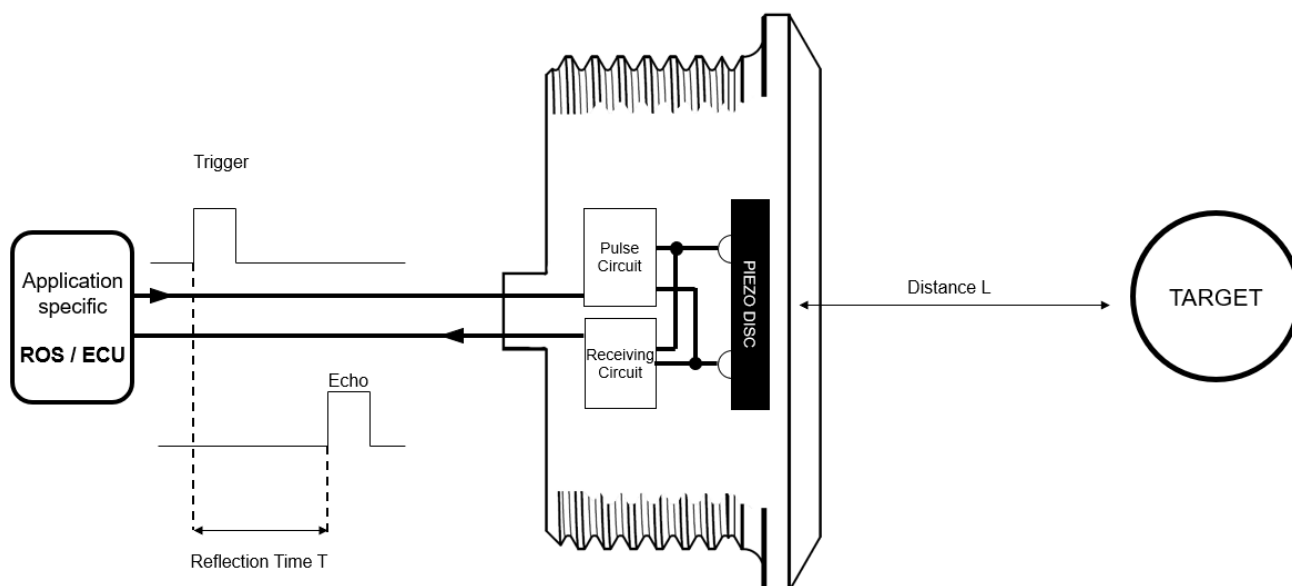

The USSM1.0 PLUS-FS is capable of transmitting the burst and receiving the echo. The same piezo element is used. This allows for a very compact setup and is called solo mode or direct measurement mode.

In some cases, it can be beneficial to separate the tasks of sending and receiving. The USSM1.0 PLUS-FS can be used like this as well. One sensor is used as a dedicated sender and one or multiple additional sensors are working as a receiver. This is referred to as pitch-and-catch or indirect measurement mode and is illustrated below. The object detection in solo mode allows for distance measurement only versus in pitch-and-catch mode additional triangulation allows spatial detection. Furthermore, the minimum detection range can be improved compared to only one sensor operating in solo mode.

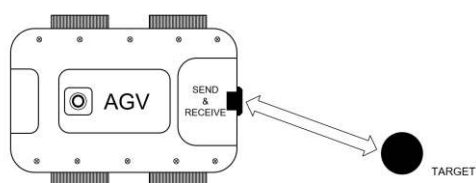

Solo-mode operation

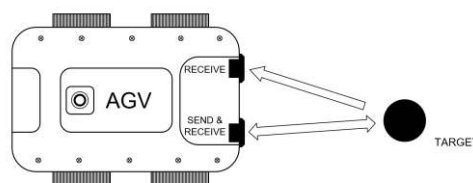

Pitch-and-catch operation

Preliminary data

IO Interface and parametrization

The 3-wire IO interface is used to communicate between the sensor and the application specific ECU (electronic control unit). Data is sent from the ECU to the sensor by pulling the IO line low for defined periods of time (pulse width modulated). The sensor supports 6 different ‘SEND’ and ‘RECEIVE’ and 11 various control commands. In addition to this, the echo detection, noise filtering, and threshold filtering can be parameterized as well to optimize the functionality of the sensor in the application.

Signal processing

The signal processing of the sensor contains analog/digital filters, amplifier/gain stages as well as signal enhancement stages. The sensitivity can be controlled depending on the ToF and improves long distance detection as well as keeping a good short distance detection performance. Echo detection is performed by comparing the echo envelope signal of the digital filter output with time dependent fully customizable threshold values.

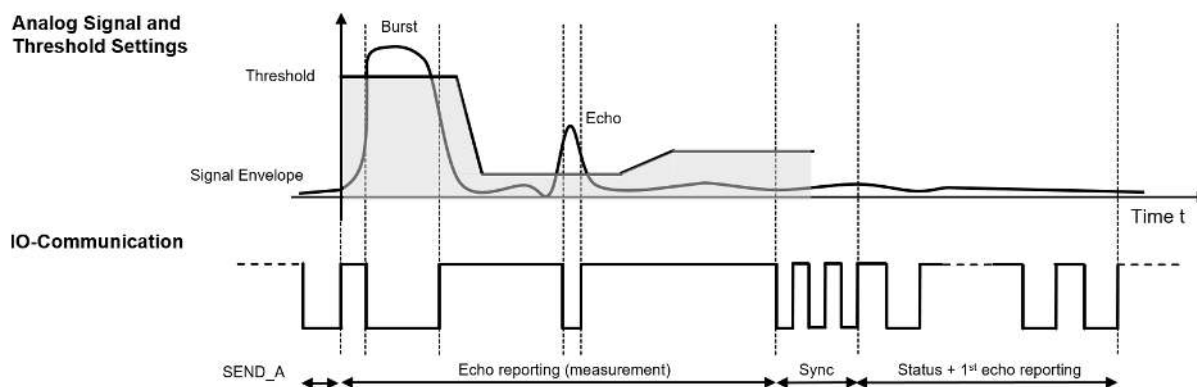

Example of measurement and IO communication handling a SEND_A command

Status information

The USSM1.0 PLUS-FS allows to send additional information with each measurement. Each measurement is followed by a sequence of pulses that contain additional status information. It can handle information like various diagnosis flags as well as echo height and width information which can be very beneficial in measurement diagnosis and interpretation.

Preliminary data

Recommended mounting

Mounting with threaded locking nut for chassis thicknesses up to 4 mm

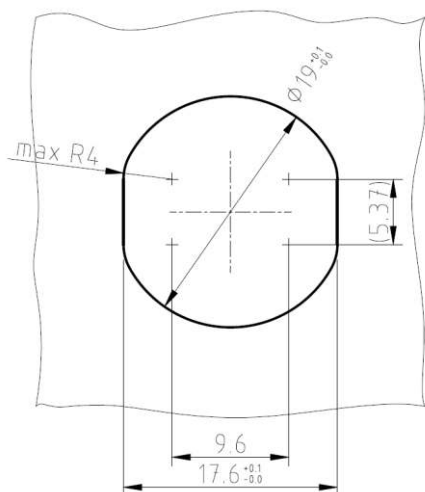

Dimensions of the recommended mounting bore for front chassis mounting



Side view



Bottom view

Example of mounting with threaded locking nut for front chassis mounting with flat gasket sealing and locking nut in 3 mm chassis plate

Preliminary data

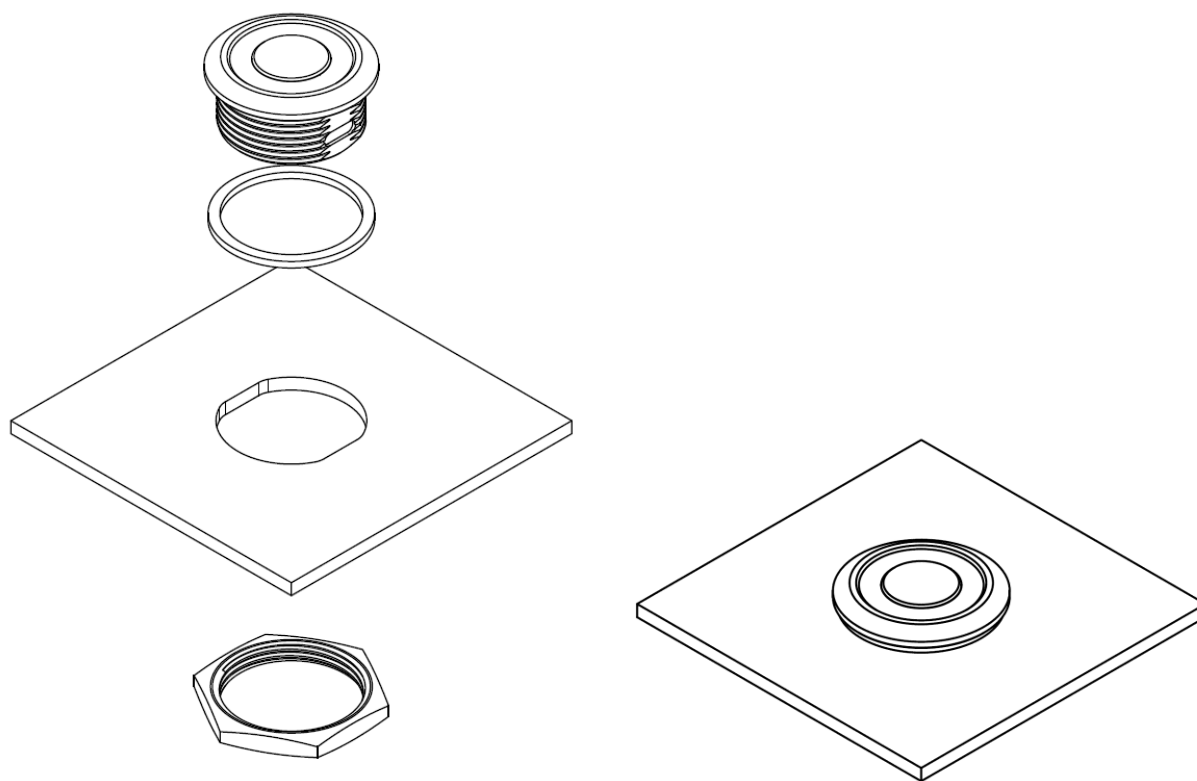

Explosion schematics of mounting with threaded locking nut showing (1) locking nut, (2) flat gasket sealing, (3) chassis plate and (4) USSM1.0 PLUS-FS

Mounting with snap hook

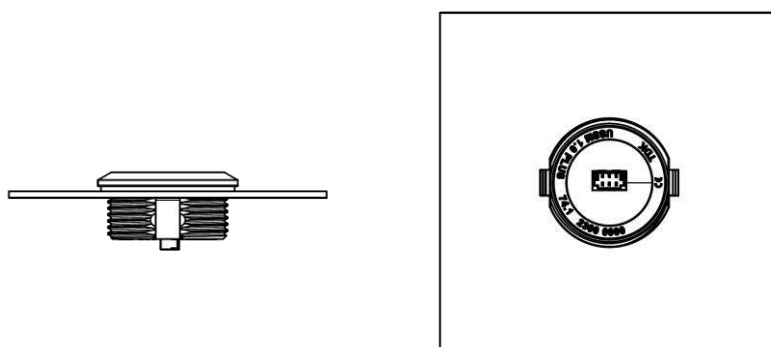

Example of mounting with snap-hook front chassis mounting with flat gasket sealing and snap hooks

Preliminary data

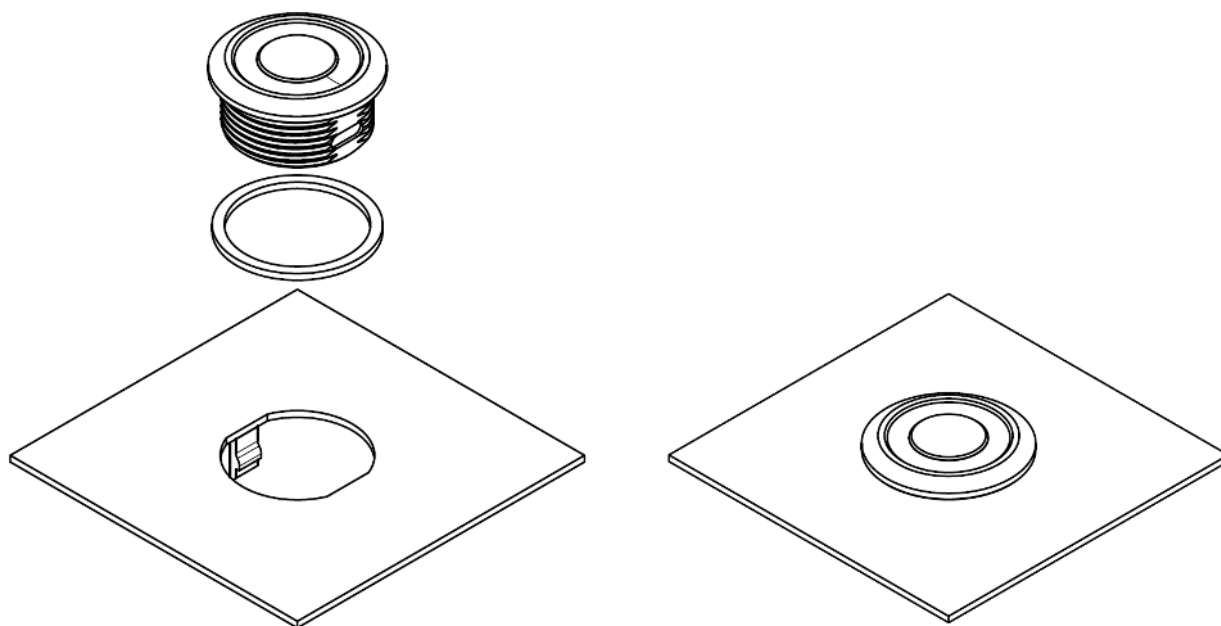

Explosion schematics of mounting with snap hook showing chassis plate with integrated snap hooks, flat gasket sealing, and USSM1.0 PLUS-FS

Preliminary data
Scope of supply

- 1 USSM1.0 PLUS-FS ultrasonic sensor
- Locking nut M19x1 (complies to ISO68 and ANSI/ASME B1.13M-2005 (R2015)) with wrench size 22 according to DIN934
- Flat gasket sealing with 21.5 mm outer diameter and 18 mm inner diameter, 1 mm thickness and hardness of Shore A 80. Material: Nitril

Labeling and packaging specification

- Delivered in a cardboard box
- Sorted in plastic protective trays and vacuum packed
- Locking nuts and flat gaskets supplied loose in plastic bag
- Packaging protects against dust and moisture
- 30 pcs. per box:

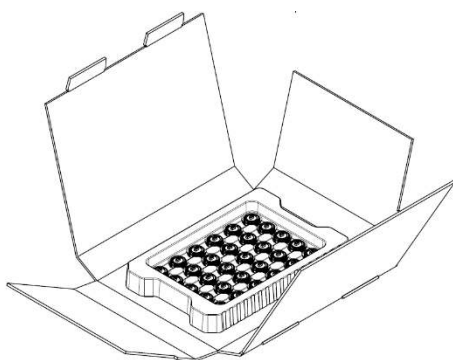

Packaging inlay architecture excluding vacuum packaging bag

Preliminary data

- Each sensor is marked with the following information:
 - TDK: Manufacturer
 - USSM1.0 PLUS-FS: Product and variant identification code
 - YYCW XXXX: Serial number including year and week of production
 - CE mark

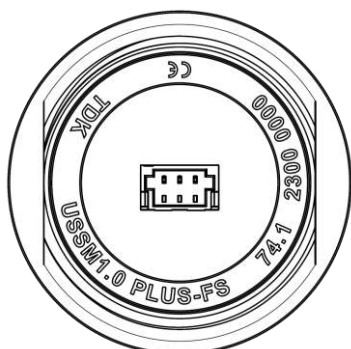

- A label is attached to the packaging box. The information provided on the label is as follows:
 - (1P) PROD ID: Product identification number
 - (9K) PROD ORDER NO: Production order number
 - (D) D/C: Packaging date in moisture proof vacuum-sealed bag
 - (T) BATCH NO: Production batch number
 - (Q) QTY: Number of components in the packaging
 - 2D barcodes: Contains product identification number, production order number and production batch number



Layout of packaging label

Preliminary data

Application specific support

To assist a quick and easy integration into the target application several different documents and sources are available:

- The available application note gives a general introduction to the sensor integration and illustrates the setup and design-in process into range finding applications for automated guided vehicles (AGVs)
- To assist the mechanical design-in process into the application, CAD files in *.STEP file format are available for
 - CAD model of the sensor and its accessories
 - Acoustic emission profile of the sensor
 - Detection curves for solo mode and pitch-and-catch mode
 - For ASIC specific support a detailed manual is available in which all features are described.
- The TDK evaluation board with its software package allows the user to monitor the sensor in many operation modes. The digital IO and the analogue readout of the echo traces can be displayed. This board assists in the early and later stages of development as it makes visible what the sensor can detect and how it responds in certain scenarios.
- An Arduino sketch and an Arduino library show the simple and straight forward implementation into an Arduino platform.

Cautions and warnings

- Do not drop the sensor.
- Do not use defect/dropped sensors.
- Do not touch the open electrical leads without ESD protection.
- Avoid exposure of the sensor to corrosive environments.
- Do not rub, scratch, or pinch the silicone seal at the front face of the sensor.
- Only clean the front face of the sensor with a soft tissue and mild chemicals, e.g. window cleaning detergents.
- To effectively clean and remove dust from the silicone at the front face of the sensor, conventional sticky tape for office applications can be used. The tape is applied and then instantly removed, taking away any dust.
- The product shall not be used in safety relevant applications.

Display of ordering codes for TDK electronics products

The ordering code for one and the same product can be represented differently in data sheets, data books, other publications, on the company website, or in order-related documents such as shipping notes, order confirmations and product labels. **The varying representations of the ordering codes are due to different processes employed and do not affect the specifications of the respective products.** Detailed information can be found on the Internet at www.tdk-electronics.tdk.com/orderingcodes.

Important notes

The following applies to all products named in this publication:

1. Some parts of this publication contain **statements about the suitability of our products for certain areas of application**. These statements are based on our knowledge of typical requirements that are often placed on our products in the areas of application concerned. We nevertheless expressly point out **that such statements cannot be regarded as binding statements about the suitability of our products for a particular customer application**. As a rule, we are either unfamiliar with individual customer applications or less familiar with them than the customers themselves. For these reasons, it is always ultimately incumbent on the customer to check and decide whether a product with the properties described in the product specification is suitable for use in a particular customer application.
2. We also point out that **in individual cases, a malfunction of electronic components or failure before the end of their usual service life cannot be completely ruled out in the current state of the art, even if they are operated as specified**. In customer applications requiring a very high level of operational safety and especially in customer applications in which the malfunction or failure of an electronic component could endanger human life or health (e.g. in accident prevention or life-saving systems), it must therefore be ensured by means of suitable design of the customer application or other action taken by the customer (e.g. installation of protective circuitry or redundancy) that no injury or damage is sustained by third parties in the event of malfunction or failure of an electronic component.
3. **The warnings, cautions and product-specific notes must be observed.**
4. In order to satisfy certain technical requirements, **some of the products described in this publication may contain substances subject to restrictions in certain jurisdictions (e.g. because they are classed as hazardous)**. Useful information on this will be found in our Material Data Sheets on the Internet (www.tdk-electronics.tdk.com/material). Should you have any more detailed questions, please contact our sales offices.
5. We constantly strive to improve our products. Consequently, **the products described in this publication may change from time to time**. The same is true of the corresponding product specifications. Please check therefore to what extent product descriptions and specifications contained in this publication are still applicable before or when you place an order.

We also **reserve the right to discontinue production and delivery of products**. Consequently, we cannot guarantee that all products named in this publication will always be available. The aforementioned does not apply in the case of individual agreements deviating from the foregoing for customer-specific products.

6. Unless otherwise agreed in individual contracts, **all orders are subject to our General Terms and Conditions of Supply**.
7. **Our manufacturing sites serving the automotive business apply the IATF 16949 standard**. The IATF certifications confirm our compliance with requirements regarding the quality management system in the automotive industry. Referring to customer requirements and customer specific requirements ("CSR") TDK always has and will continue to have the policy of respecting individual agreements. Even if IATF 16949 may appear to support the acceptance of unilateral requirements, we hereby like to emphasize that **only requirements mutually agreed upon can and will be implemented in our Quality Management System**. For clarification purposes we like to point out that obligations from IATF 16949 shall only become legally binding if individually agreed upon.

Important notes

8. The trade names EPCOS, CarXield, CeraCharge, CeraDiode, CeraLink, CeraPad, CeraPlas, CSMP, CTVS, DeltaCap, DigiSiMic, ExoCore, FilterCap, FormFit, InsuGate, LeaXield, MiniBlue, MiniCell, MKD, MKK, ModCap, MotorCap, PCC, PhaseCap, PhaseCube, PhaseMod, PhiCap, PowerHap, PQSine, PQvar, SIFERRIT, SIFI, SIKOREL, SilverCap, SIMDAD, SiMic, SIMID, SineFormer, SIOV, ThermoFuse, WindCap, XieldCap are **trademarks registered or pending** in Europe and in other countries. Further information will be found on the Internet at www.tdk-electronics.tdk.com/trademarks.

Release 2022-07