

Data Sheet and User Guide

SMD Test Fixture TL89S1

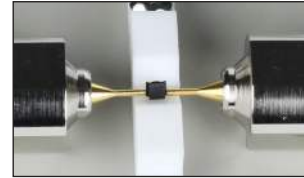

Component insertion site (closeup)

Test fixture for measuring small surface-mount devices (SMD)

The TL89S1 fixture is designed to probe SMD components with repeatable and accurate impedance measurements. The contactors are easily adjusted to accommodate different sized components while applying the appropriate contact pressure. This test fixture is attached directly to the front panel of LCR models 889B, 891, 894, and 895.

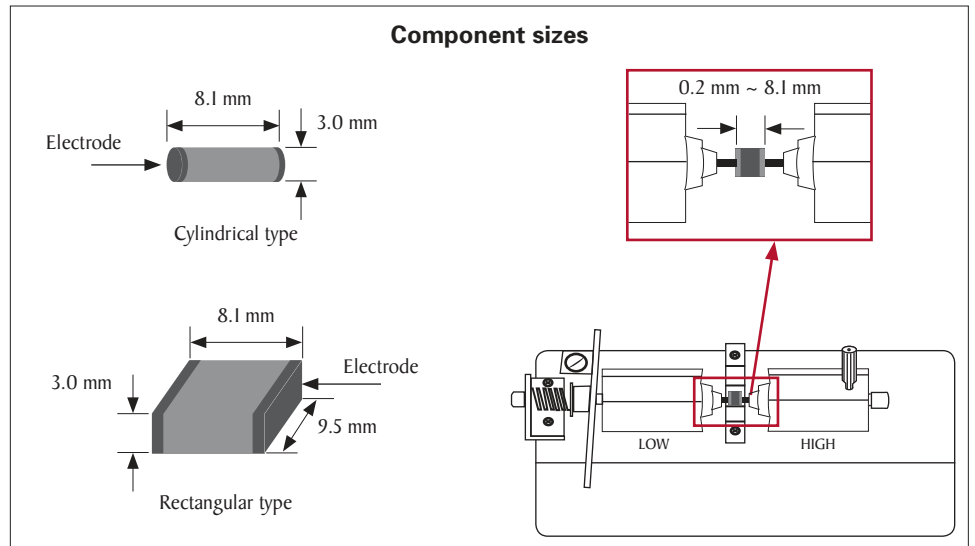
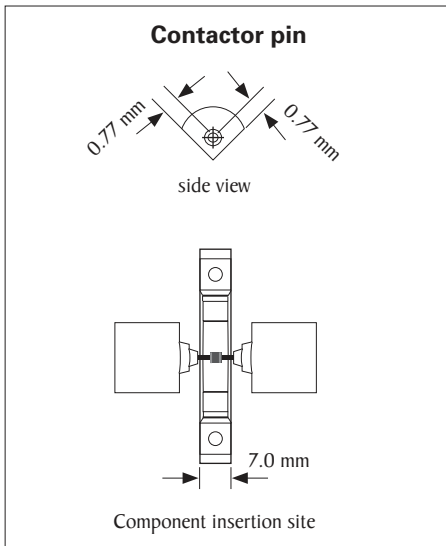

Note: All mechanical measurements are typical

Specification	TL89S1
Frequency	DC to 10 MHz
DC Bias	± 40 V peak max (AC+DC)
Operating Temperature	0 °C to 40 °C
Terminal Connection	BNC, 4 terminal-pair
Dimensions (W x H x D)	5.125 x 2.37 x 3.31 inches (130 x 60.3 x 84 mm)
Weight:	0.67 lbs (0.305 kg)

Adjusting the contactor pins

I

Loosen the lock screw (I) by turning the screw counter clockwise 2 full turns.

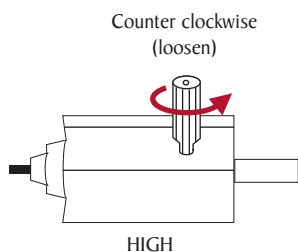

II

Press the High contactor (2) to start the extraction, grip the Contactor rod (4) on the opposite side and pull the contactor open to create a gap large enough to loosely fit the new component. If more space is required, push the Insertion lever (6) to the left until the component fits into the Component insertion site (5).

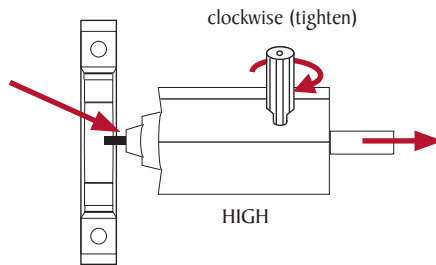

III

Gently press in on contactor rod (4) until the new component is centered in component insertion site (5).

Continue to apply pressure to the contactor rod (4) while tightening the lock screw by turning it clockwise. Do not over tighten the lock screw. This completes the adjustment process and components of the same size can now be easily changed.

Press the Insertion lever (6) to retract the Low contactor pin. While holding the lever open, remove the previous component and place the next component in the insertion site (5). Slowly release the lever to contact the new component and begin the next measurement.

Note: The contactor pins should be cleaned periodically to remove contamination.

1. Lock screw
2. High contactor pin
3. Low contactor pin
4. Contactor rod
5. Component insertion site
6. Insertion lever

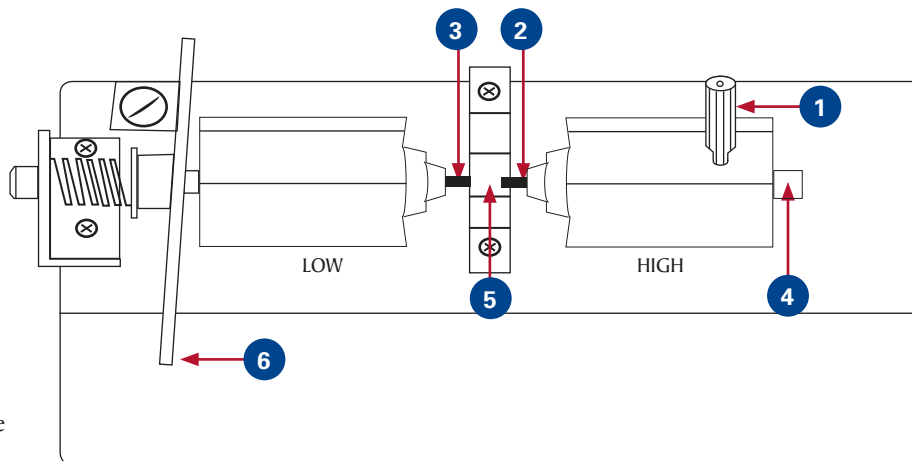

Test fixture illustration