

# LX8213

## HIGH SPEED LOW NOISE CMOS LDO REGULATOR

### EVALUATION BOARD

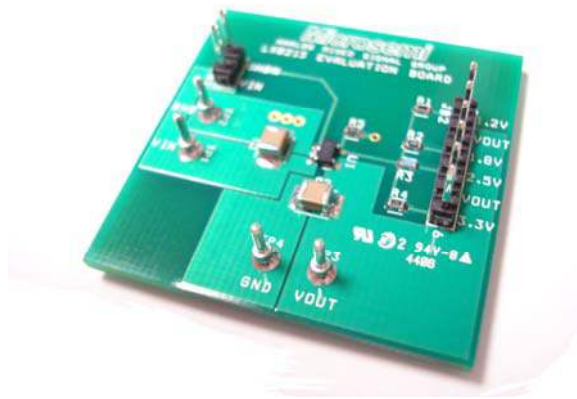

## INTRODUCTION TO PRODUCT

The LX8213 Evaluation Board is available from Microsemi for evaluating the functionality and performance of the LX8213 high speed, low noise CMOS based LDO regulator. The evaluation board allows the user to set either a 1.2V, 1.8V, 2.5V, or 3.3V output via an on board jumper.

## KEY FEATURES

- Wide Operating Voltage Range: 2.5V to 6V
- 1.2V, 1.8V, 2.5V or 3.3V Output Voltage via On Board Setting
- 1uF Input and Output Low ESR Ceramic Capacitors
- Low Dropout Voltage: 170mV @ 3.3V 300mA
- Low Standby Current: Typical 0.1uA
- Low Quiescent Current: Typical 60uA
- Low Output Noise: 60uVrms
- Excellent Line and Load Regulation
- Short Current Limit of Typically 50mA
- Over Temperature Protection
- High Ripple Rejection: 65dB @ 1kHz, 45dB @ 10kHz

## APPLICATIONS

- Personal Computers
- Datacom

## PART SPECIFIC INFORMATION

IC PART NUMBER	DESCRIPTION
LX8213-00ISE	Adjustable Output CMOS LDO Regulator, Plastic SOT23 5 Pin.

Table 1 - PART INFORMATION

EVALUATION BOARD PART NUMBER	DESCRIPTION
LX8213-00ISE EVAL KIT	Evaluation PCB for the LX8213-00ISE device.

Table 2 - EVALUATION BOARD INFORMATION

### SCHEMATIC AND PCB LAYOUT

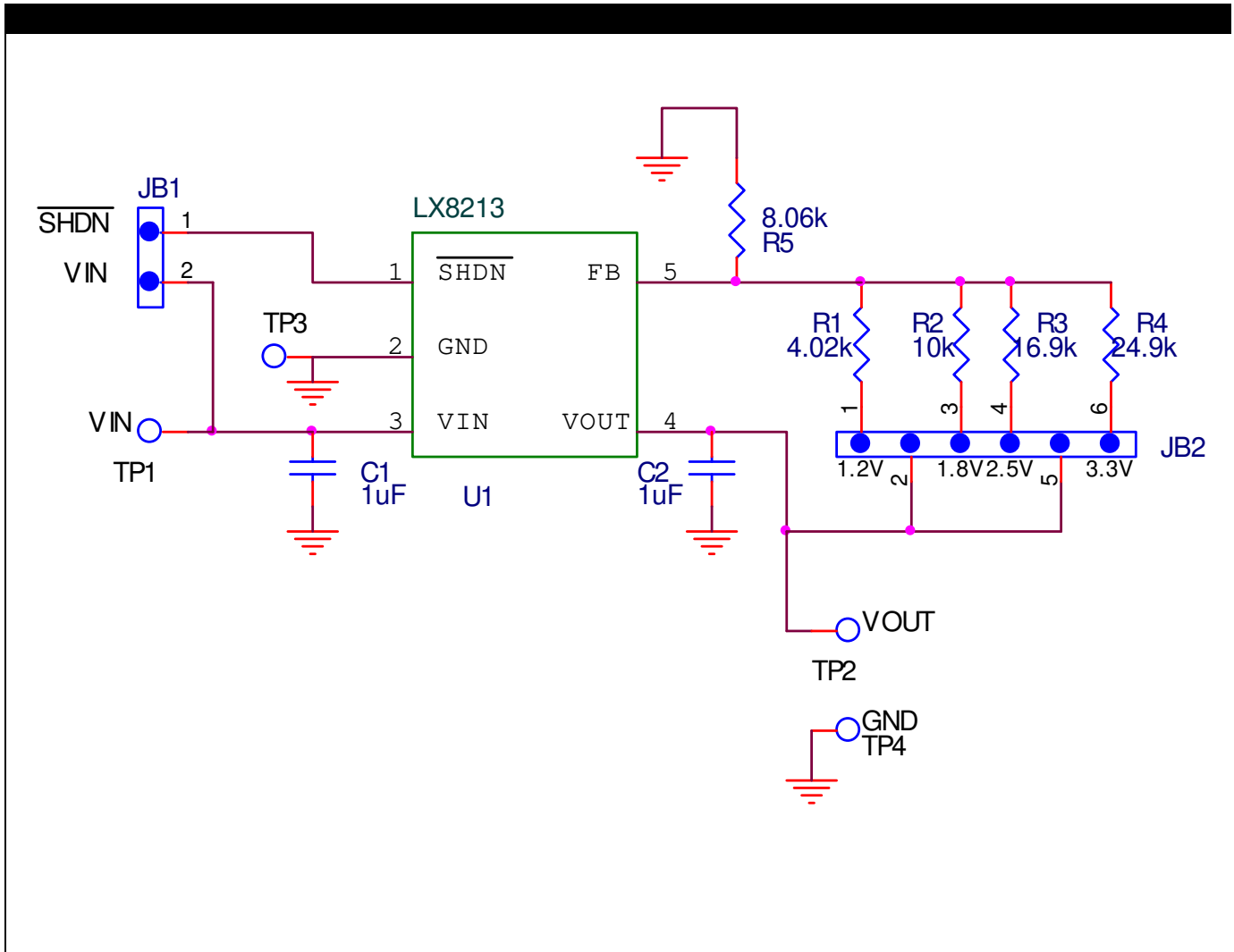

Figure 1 – LX8213 Evaluation Board Schematic

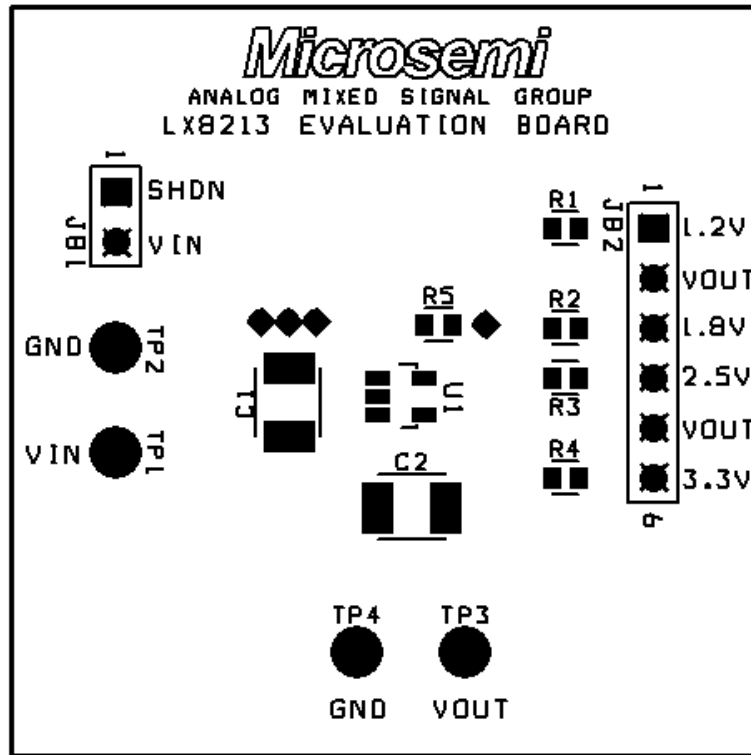

Figure 2 – Silkscreen & Solder Mask

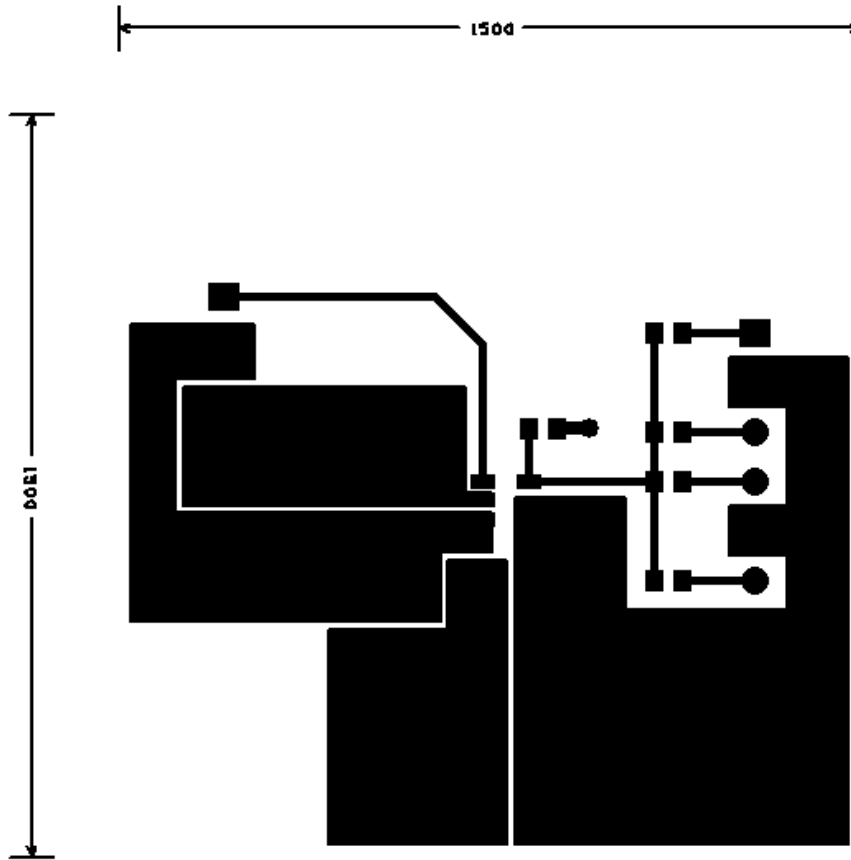
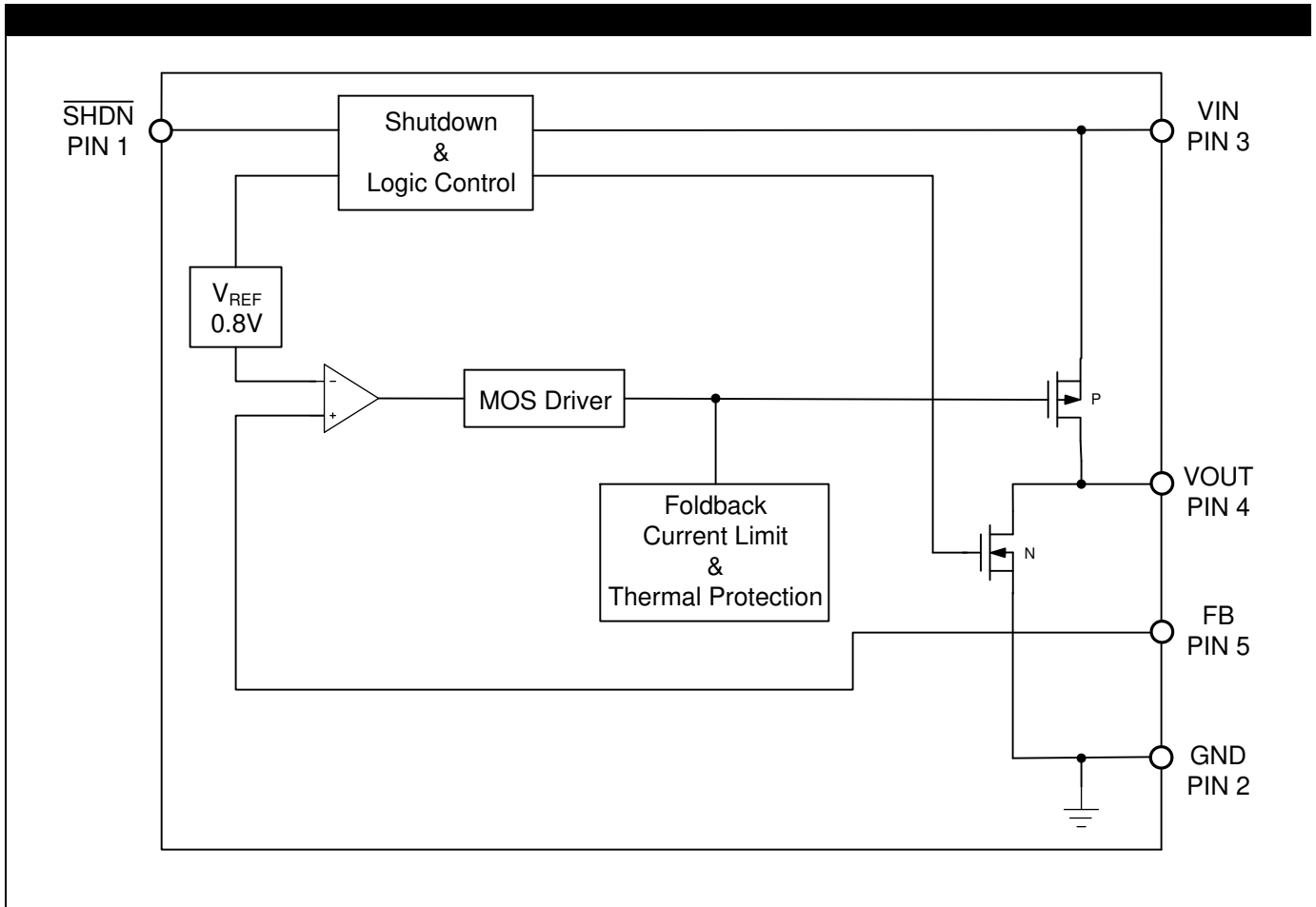

Figure 3 – Top Layer

**IC BLOCK DIAGRAM**



**Figure 4 – LX8213 Simplified Block Diagram**

## LX8213 EVALUATION BOARD

**Schematic:** The LX8213 Evaluation Board schematic is shown in Figure 1.

**PCB Layout:** The LX8213 Evaluation Board layout is shown in Figure 2 and Figure 3.

**Connections:** The LX8213 Evaluation Board test point and jumper connections are described below.

Test Point	Pin Name	Function
TP1	VIN	LX8213 Device Input
TP2	OUTPUT	LX8213 Device Output
TP3	GND	Ground, Input Return Power
TP4	GND	Ground, Output Return Power

**Table 3 – Test Point Assignment**

**Jumper Setting:** Jumper JB1 allows SHDN to be connected to VIN to enable the LX8213. When SHDN pin is left floating, an internal pull-down will disable the device. An external source can also be used to toggle SHDN via pin 1 of JB1. Jumper JB2 sets the LX8213 output voltage to one of four levels: 1.2V, 1.8V, 2.5V, or 3.3V. Please refer to Table 5 for setting the desired output voltage.

Device Enabled	Jumper JB1 Setting
YES	Connect pins 1 and 2
NO	OPEN

**Table 4 – LX8213 Device Enable Setting**

Output Voltage	Jumper JB2 Setting
1.2V	Connect pins 1 and 2
1.8V	Connect pins 2 and 3
2.5V	Connect pins 4 and 5
3.3V	Connect pins 5 and 6

**Table 5 – LX8213 Output Voltage Setting**

**Test Setup Considerations:** For good load transient response and noise rejection, the 1uF input bypass capacitor may not be sufficient if additional parasitic inductance is introduced by the cables via the bench power supply to the LX8213 input. Please use additional input bypassing to help alleviate the parasitic inductance. Recommended capacitance value depends on the setup; however, a 10uF electrolytic should suffice to account for typical power supply cable connection parasitic. In real application the extra input bypassing is not needed.

**LX8213 EVALUATION BOARD BUILD OF MATERIALS**

**MISCELLANEOUS COMPONENTS**

Line Item	Part Description	Manufacturer & Part #	Case	Reference Designators	Qty
1	Microsemi IC – Low Dropout Linear Regulator	Microsemi, LX8213-00ISE	SOT23-5	U1	1
2	Header, 2 Positions, Vertical Mount, 0.1 Center	3M, 929647-02-36-1	Through Hole	JB1	1
3	Header, 6 Positions, Vertical Mount, 0.1 Center	3M, 929647-02-36-1	Through Hole	JB2	1
4	Test Point, Miniature Surface Mount	Keystone, 5015	Through Hole	TP1, TP2, TP3	3

**CAPACITORS**

Line Item	Part Description	Part Description	Case	Reference Designators	Qty
5	Ceramic Capacitor, 1µF, 6.3V, ±15%, X5R	Panasonic, ECJ-1VB0J105K	0603	C1, C2	2

**RESISTORS**

Line Item	Part Description	Part Description	Case	Reference Designators	Qty
6	Resistor, 4.02K, 1%, 1/16W	Panasonic, ERJ-3EKF4021V	0603	R1	1
7	Resistor, 10k, 1%, 1/16W	Panasonic, ERJ-3EKF1002V	0603	R2	1
8	Resistor, 16.9k, 1%, 1/16W	Panasonic, ERJ-3EKF1692V	0603	R3	1
9	Resistor, 24.9k, 1%, 1/16W	Panasonic, ERJ-3EKF2492V	0603	R4	1
10	Resistor, 8.06k, 1%, 1/16W	Panasonic, ERJ-3EKF8061V	0603	R5	1