

PART NUMBER	PACK	HOOD SIZE
8655BZETIB10KLF	KIT	09

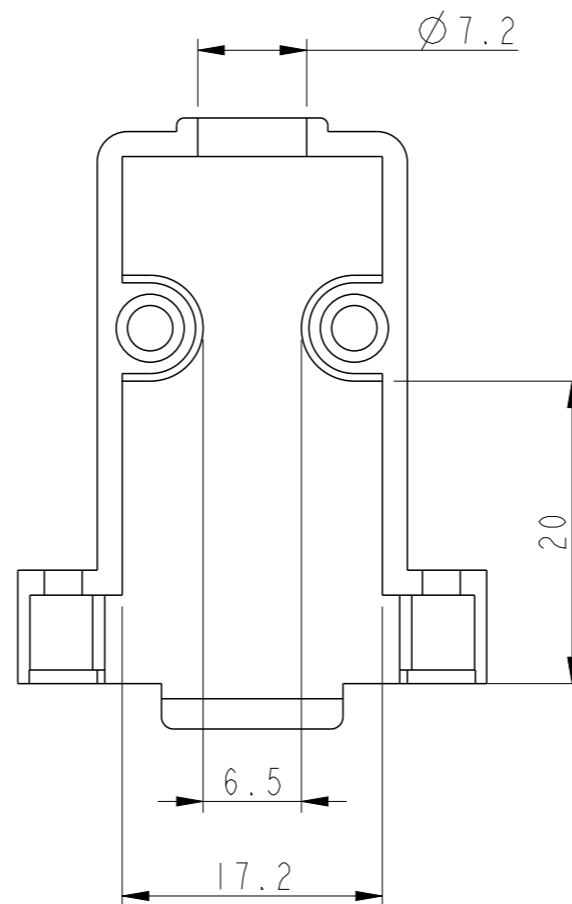
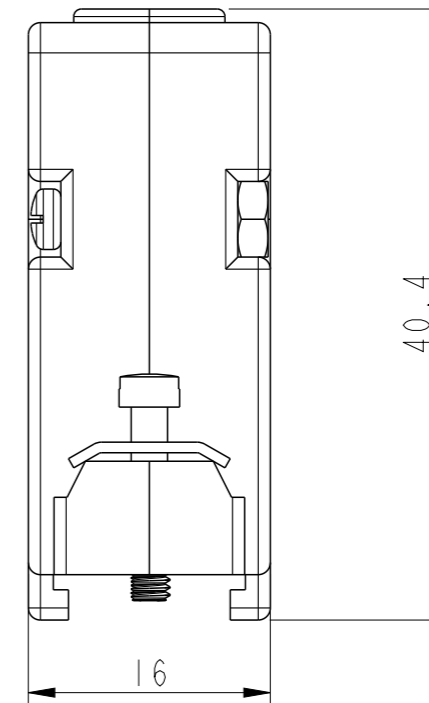
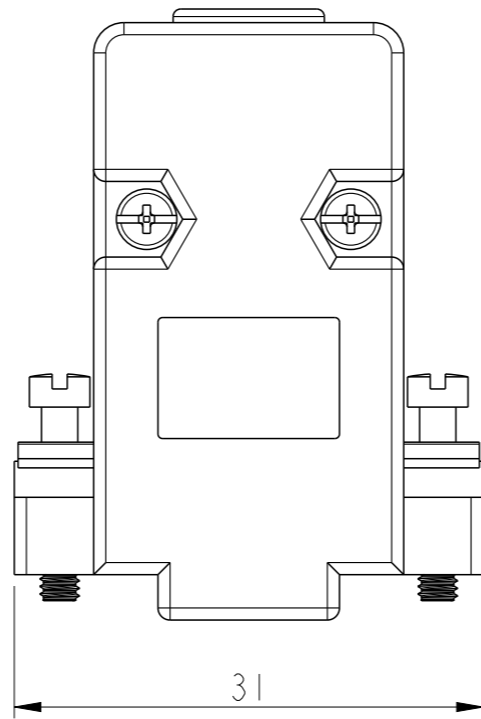
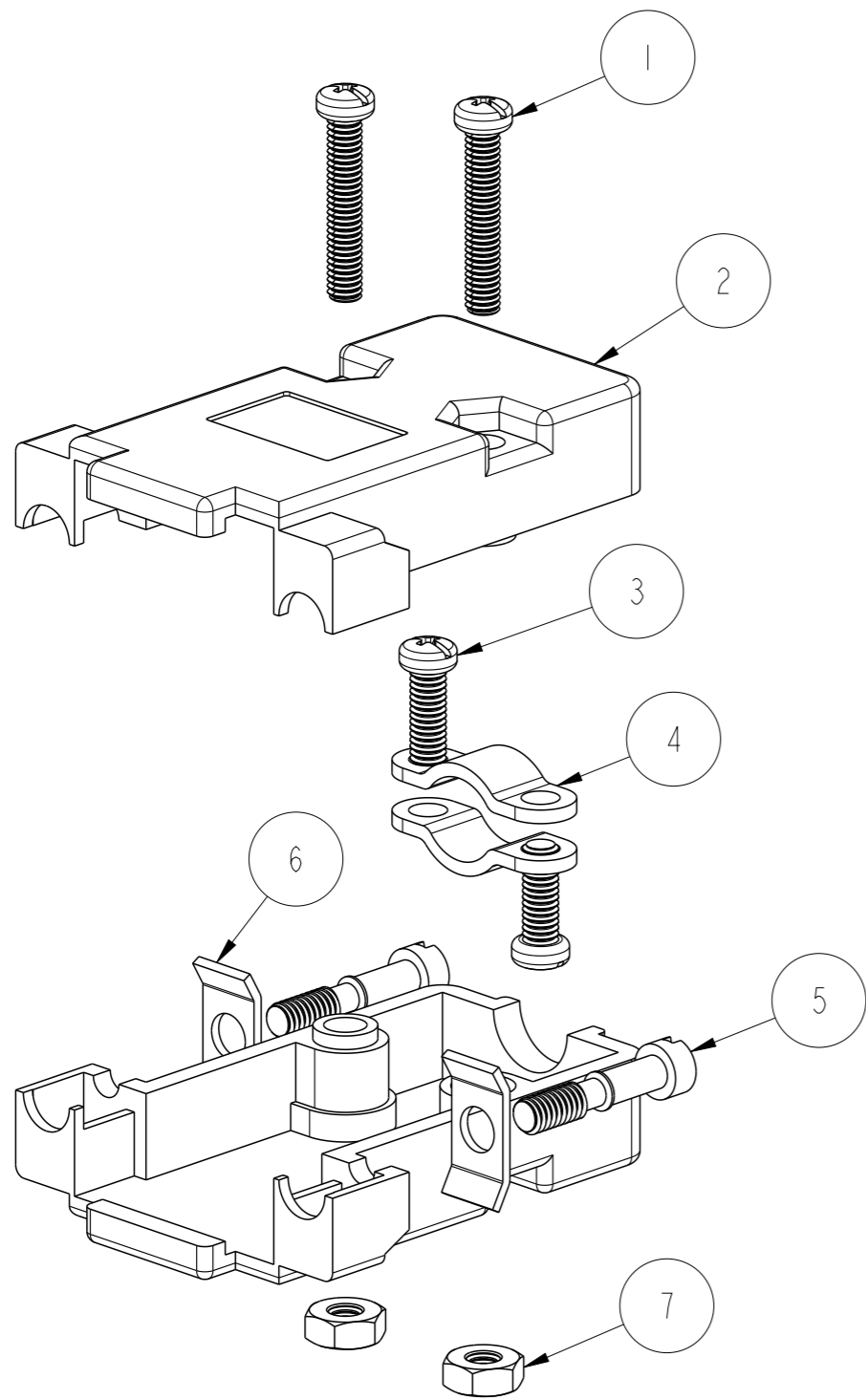

NOTES: (FOR EVERY SIZES)  
 1- OPERATING TEMPERATURE: -40°C TO +120°C  
 2- INDIVIDUAL KITS SEALED IN PLASTIC COVER IN UNASSEMBLED FORM.  
 BOM AS SHOWN IN TABLE

RoHS INFORMATION:  
 - THE LF PRODUCT MEETS EUROPEAN UNION DIRECTIVES AND OTHER COUNTRY REGULATIONS AS DESCRIBED IN GS+22-009  
 - THE PRODUCT IS NOT INTENDED TO BE EXPOSED TO A MANUFACTURING SOLDER PROCESS

ITEM NO.	QTY.	PART DESCRIPTION
1	2	HOOD SCREW
2	2	HOOD HALVE
3	2	CABLE CLAMP SCREW (SHORT)
4	2	CABLE CLAMP
5	2	SHORT JACKSCREW UNC 4-40
6	2	CLAMP FOR JACKSCREW
7	2	NUT FOR HOOK SCREW

spec ref	dr	Dipu Joseph	2020/09/25	projection	mm	size	A3	scale	2:1
tolerance std	eng	Detouillon, Da	2020/11/17			ecn no	-	rel level	Released
ISO 406 ISO 1101	chr	-	-						
surface	linear	0.X	±0.3		title	DSUB METALIZED HOOD	dwg no	8655BZxxIB10KLF	rev
		0.XX	±0.10						
ISO 1302	angular	0°	±2°	cat. no.	-	Product - Customer Drw	sheet 1 of 4	A	

PART NUMBER	PACK	HOOD SIZE
8655BZATIB10KLF	KIT	15

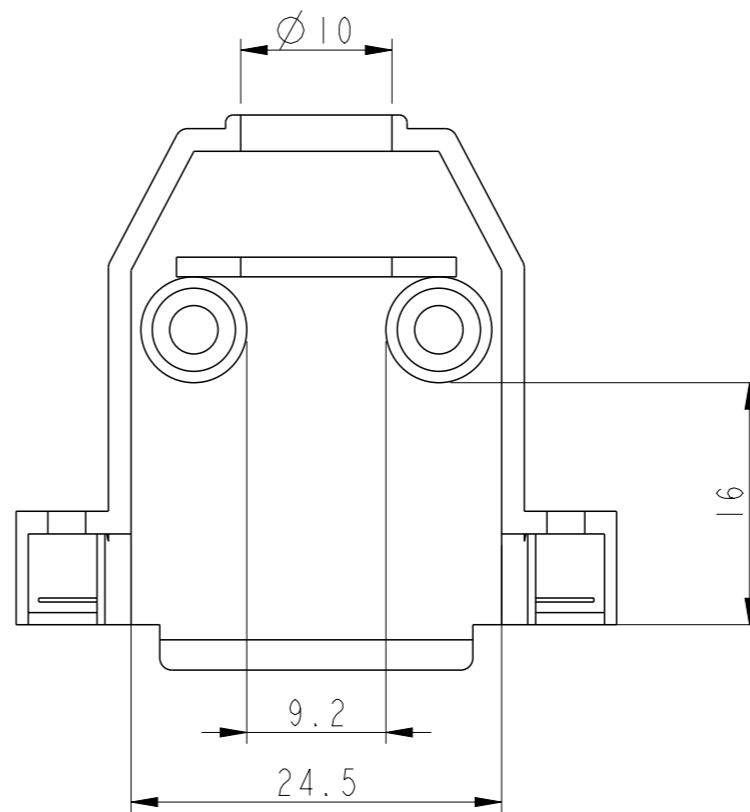
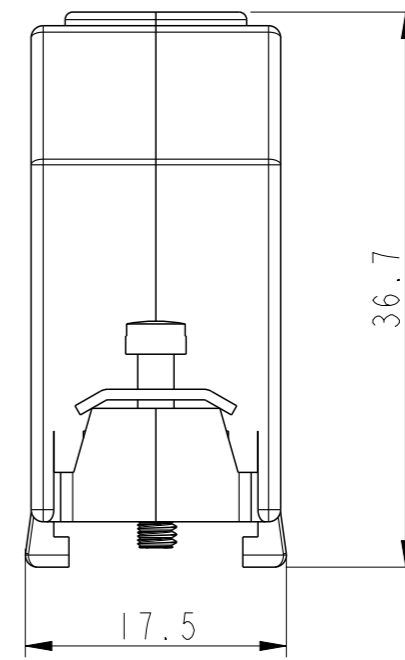
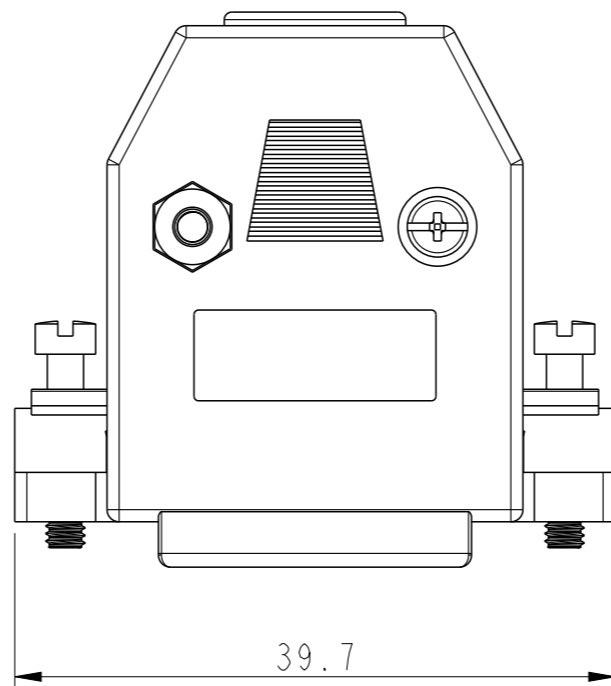
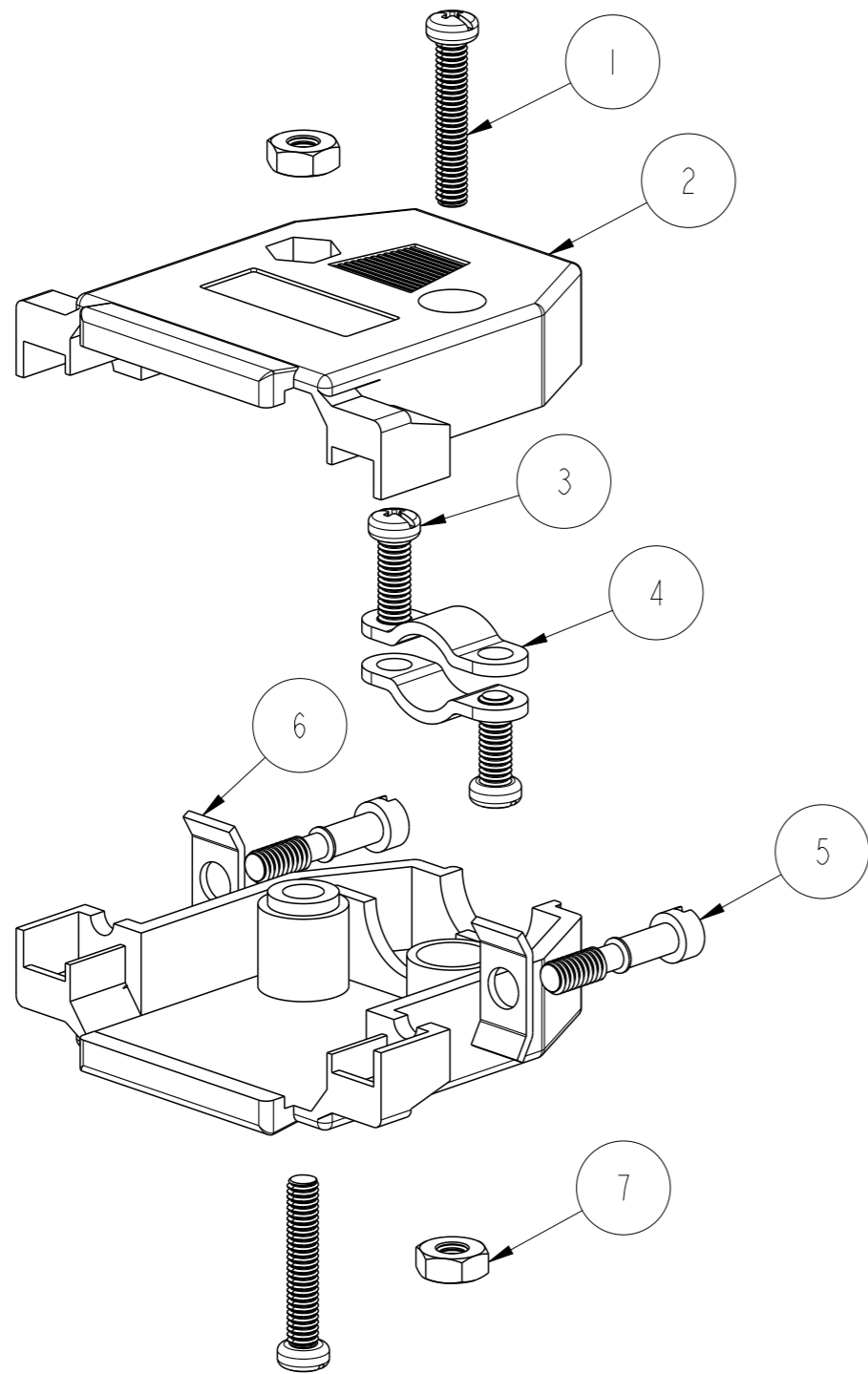

ITEM NO.	QTY.	PART DESCRIPTION
1	2	HOOD SCREW
2	2	HOOD HALVE
3	2	CABLE CLAMP SCREW (SHORT)
4	2	CABLE CLAMP
5	2	SHORT JACKSCREW UNC 4-40
6	2	CLAMP FOR JACKSCREW
7	2	NUT FOR HOOK SCREW

spec ref	dr	Dipu Joseph	2020/09/25	projection	mm	size	A3	scale	1:1
tolerance std	eng	Detouillon, Da	2020/11/17			ecn no	-	rel level	Released
ISO 406 ISO 1101	chr	-	-						
surface	linear	0.X	±0.3	<b>Amphenol FCI</b>		DSUB METALIZED HOOD		dwg no 8655BZxxIB10KLF	rev A
		0.XX	±0.10						
ISO 1302	angular	0°	±2°	cat. no.	-	Product - Customer Drw		sheet 2 of 4	

PART NUMBER	PACK	HOOD SIZE
8655BZBTIB10KLF	KIT	25

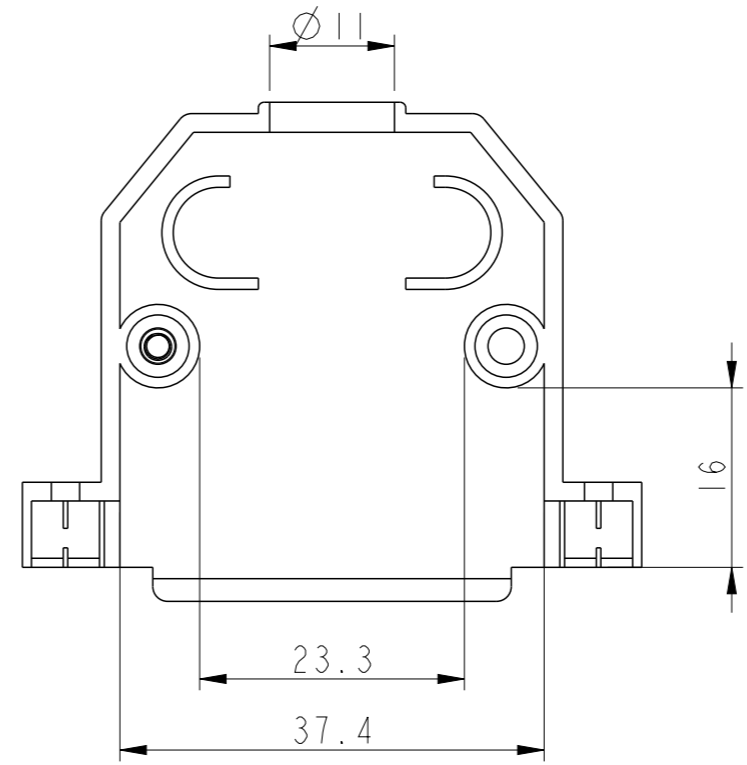
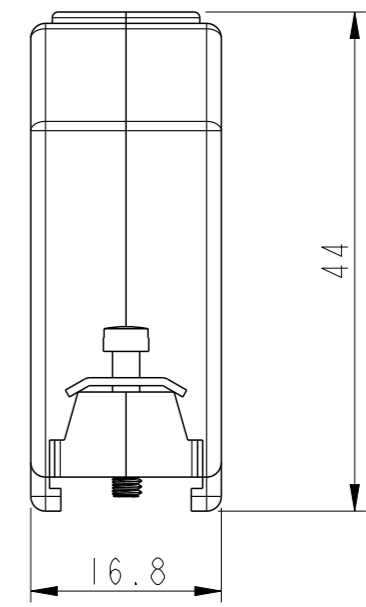
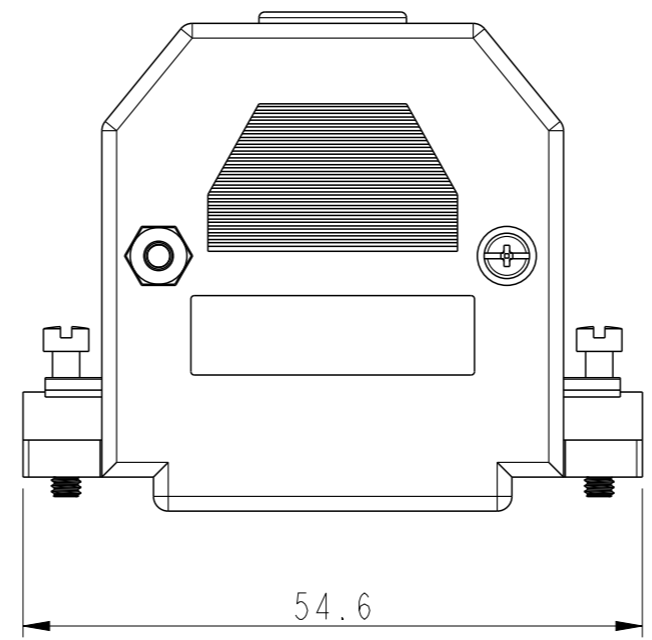
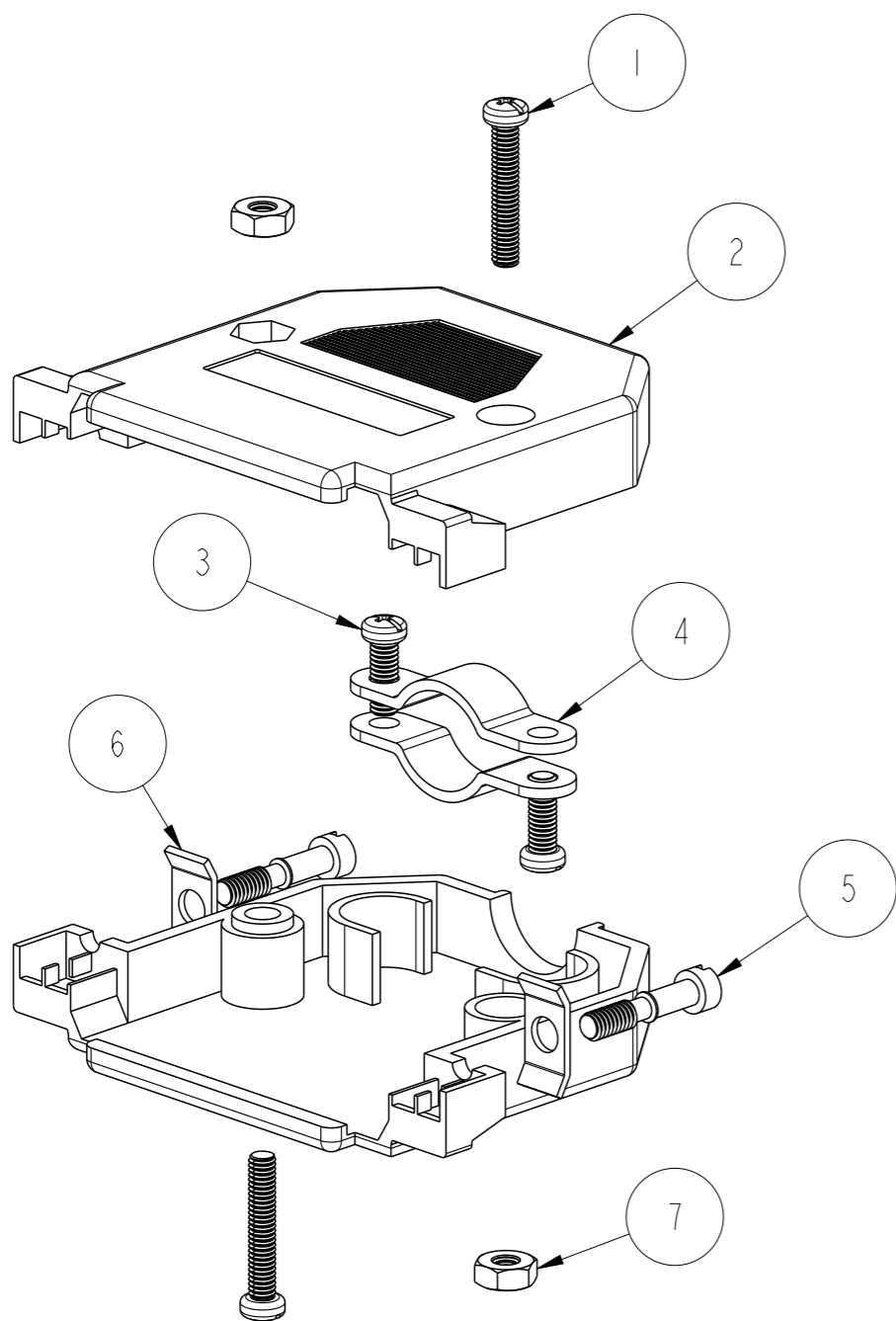

ITEM NO.	QTY.	PART DESCRIPTION
1	2	HOOD SCREW
2	2	HOOD HALVE
3	2	CABLE CLAMP SCREW (SHORT)
4	2	CABLE CLAMP
5	2	SHORT JACKSCREW UNC 4-40
6	2	CLAMP FOR JACKSCREW
7	2	NUT FOR HOOK SCREW

spec ref	dr	Dipu Joseph	2020/09/25	projection	mm	size	A3	scale	1:1		
tolerance std	eng	Detouillon, Da	2020/11/17			ecn no	-	rel level	Released		
ISO 406 ISO 1101	chr	-	-								
surface	linear	0.X	$\pm 0.3$	<b>Amphenol FCI</b>	product family	-	dsb METALIZED HOOD	dwg no	8655BZxxIB10KLF	rev	<b>A</b>
		0.XX	$\pm 0.10$								
ISO 1302	angular	0°	$\pm 2^\circ$	cat. no.	-	Product - Customer Drw	sheet 3 of 4				

Amphenol FCI

© 2016 AFCI

PART NUMBER	PACK	HOOD SIZE
8655BZCTIB10KLF	KIT	37

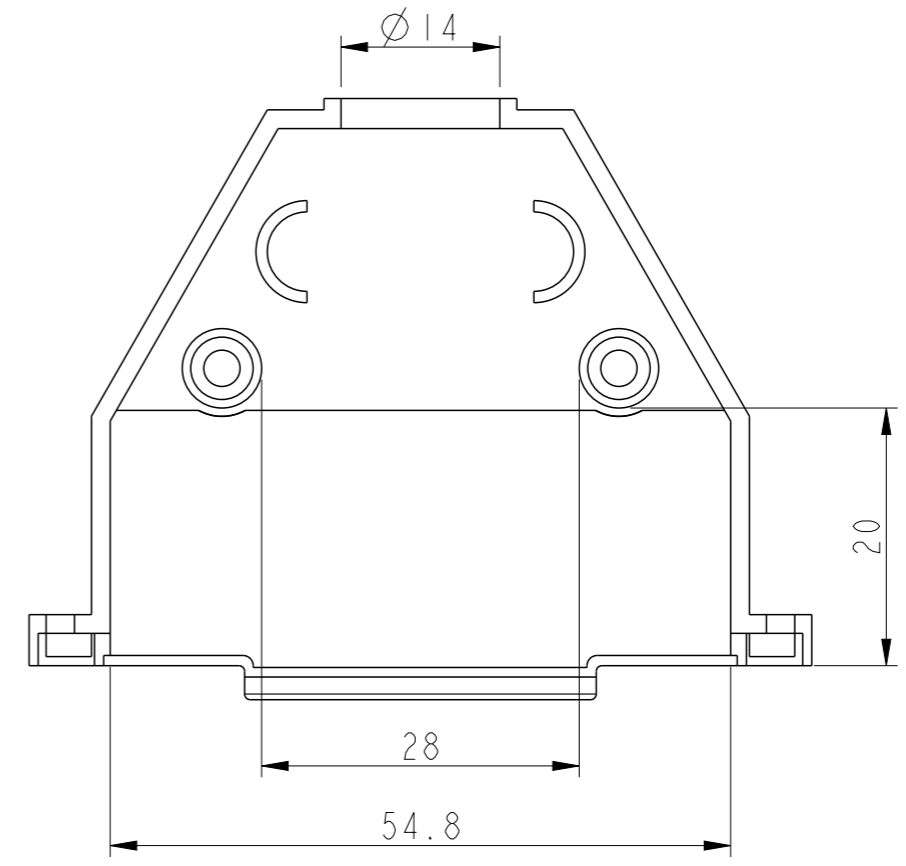
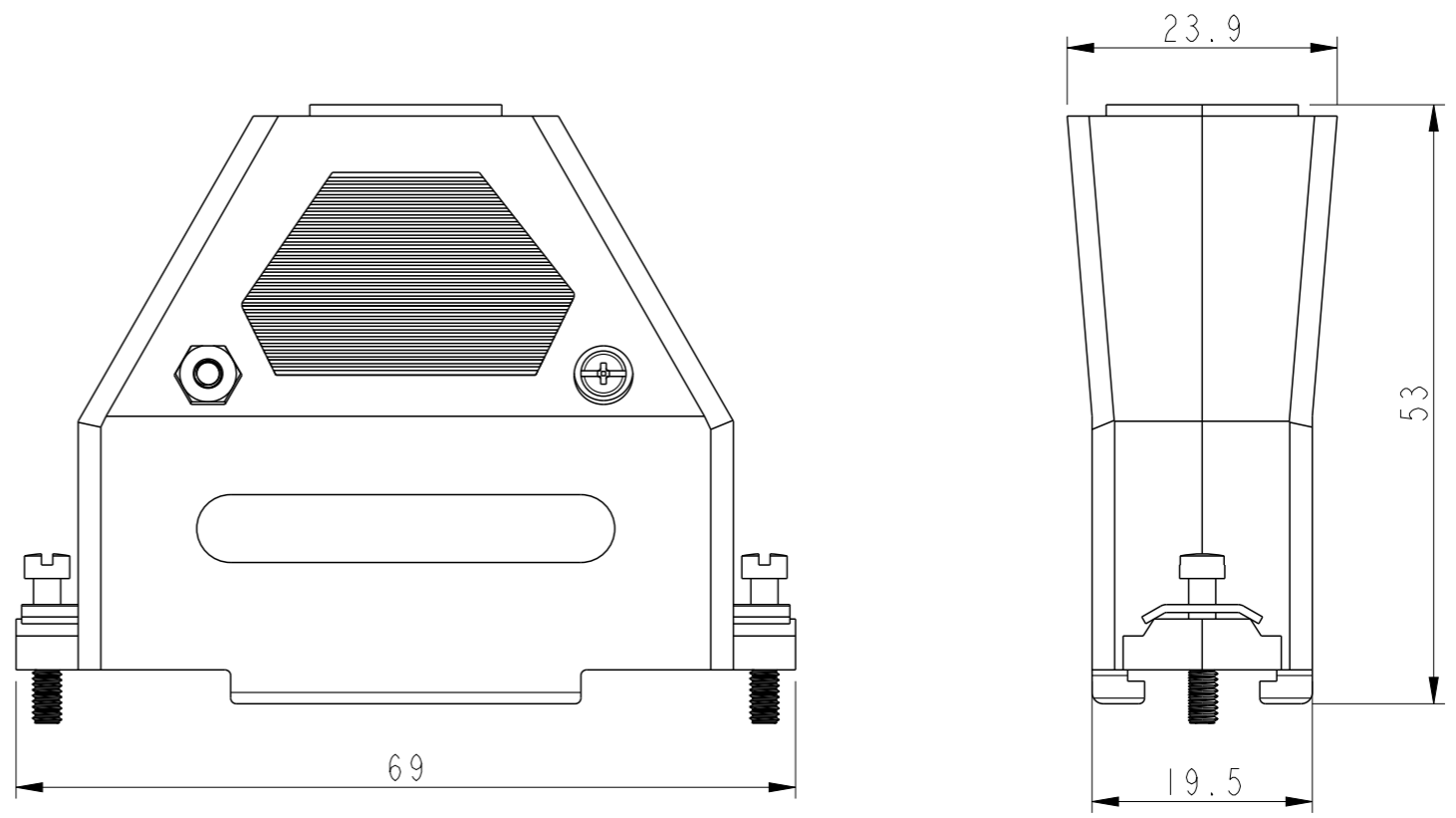
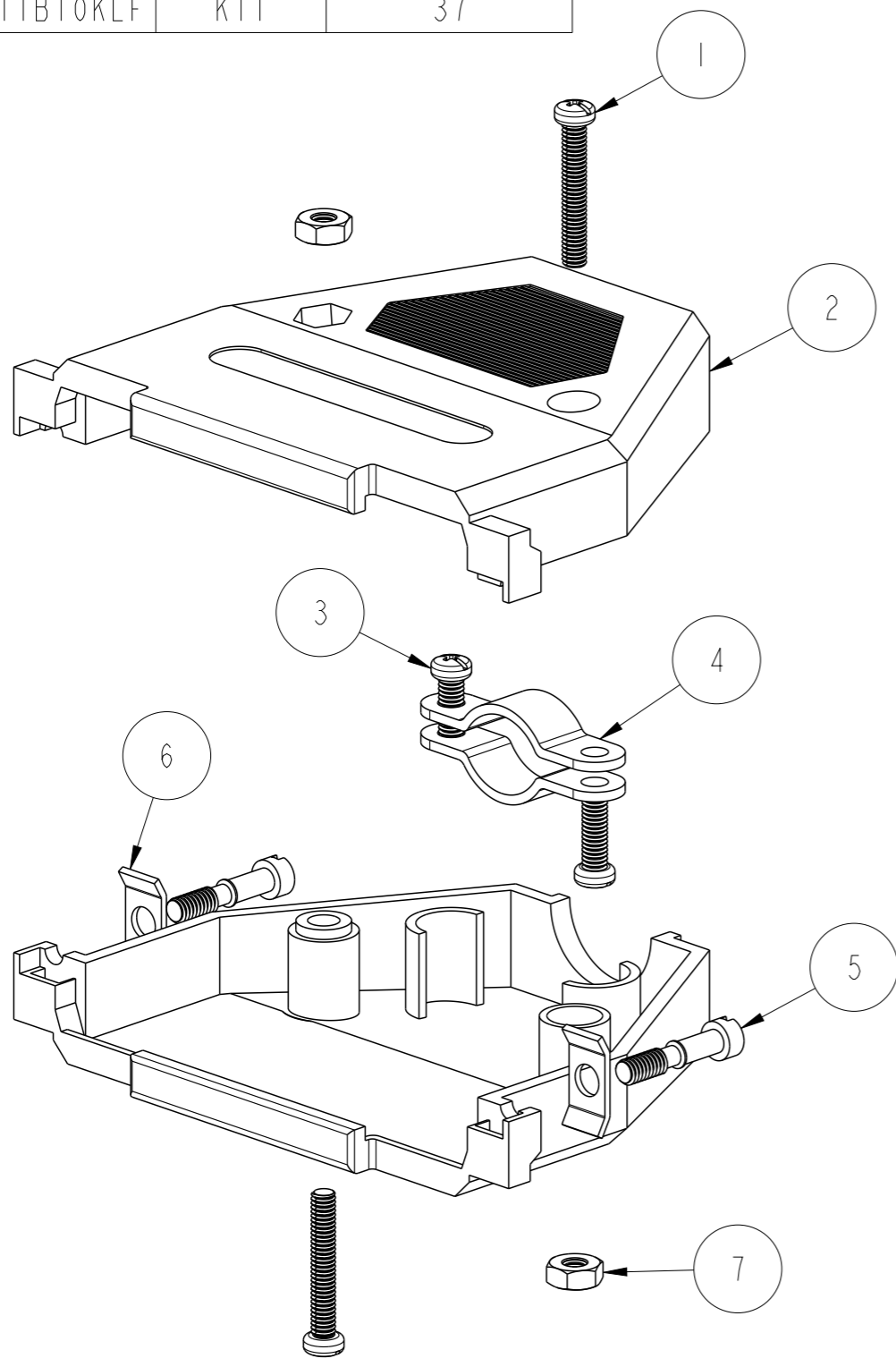

ITEM NO.	QTY.	PART DESCRIPTION
1	2	HOOD SCREW
2	2	HOOD HALVE
3	2	CABLE CLAMP SCREW (SHORT)
4	2	CABLE CLAMP
5	2	SHORT JACKSCREW UNC 4-40
6	2	CLAMP FOR JACKSCREW
7	2	NUT FOR HOOK SCREW

spec ref	dr	Dipu Joseph	2020/09/25	projection	mm	size	A3	scale	1:1
tolerance std	eng	Detouillon, Da	2020/11/17			ecn no	-	rel level	Released
ISO 406 ISO 1101	chr	-	-						
surface	linear	0.X	±0.3		<b>DSUB METALIZED HOOD</b>	dwg no	8655BZxxIB10KLF	rev	A
		0.XX	±0.10						
ISO 1302	angular	0°	±2°	cat. no.	-	Product - Customer Drw	sheet 4 of 4		

Amphenol FCI

© 2016 AFCI