

PART NUMBER	SSI-LXR1612GD-250	REV.	A
DATE	E.C.N. NUMBER AND REVISION COMMENTS		REV.
07.22.14	E.C.N. #11914.		A

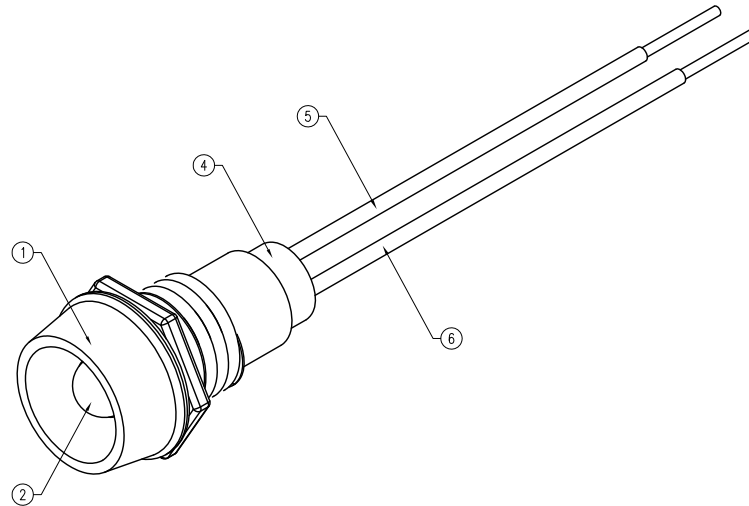

PCB PANEL CUTOUT

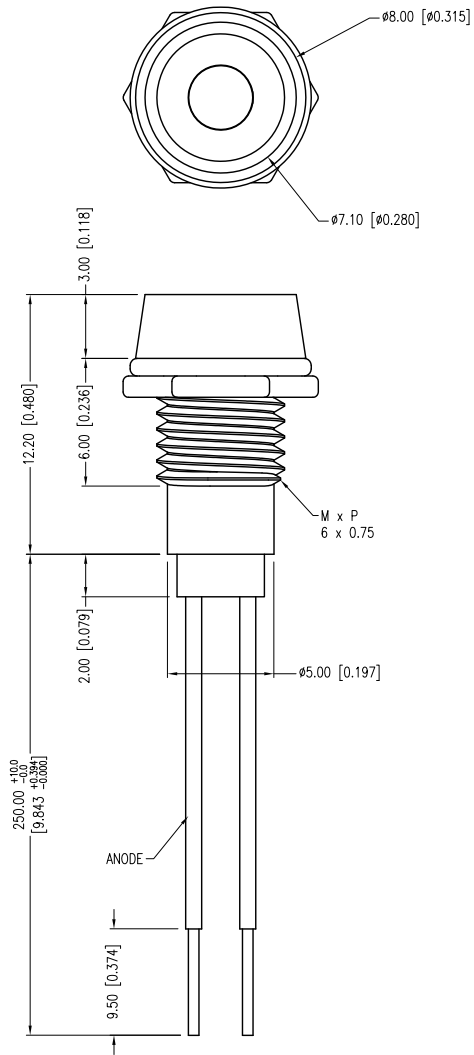
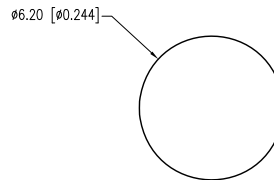

ELECTRO-OPTICAL CHARACTERISTICS $T_a=25^{\circ}\text{C}$				$I_f=20\text{mA}$	
PARAMETER	MIN	TYP	MAX	UNITS	UNITS
PEAK WAVELENGTH		565		nm	
FORWARD VOLTAGE		2.2	2.6	Vf	
REVERSE VOLTAGE	5.0			Vr	$I_r=100\mu\text{A}$
AXIAL INTENSITY		30		mcd	$I_f=20\text{mA}$
VIEWING ANGLE		60		2x theta	
EMITTED COLOR:	GREEN				
EPOXY LENS FINISH:	GREEN DIFFUSED				

LIMITS OF SAFE OPERATION AT 25°C		
PARAMETER	MAX	UNITS
PEAK FORWARD CURRENT*	150	mA
STEADY CURRENT	25	mA
POWER DISSIPATION	105	mW
DERATE FROM 25°C	-1.6	mW/°C
OPERATING TEMP.	-40 TO +85	°C
STORAGE TEMP.	-40 TO +85	°C
SOLDERING TEMP.	+260	°C
2.0mm FROM BODY	3	SEC. MAX.

* $t < 10\mu\text{s}$

A NOTES:

- SSI-LXR1612, CHROME HOUSING.
- SSL-LX3054GD, GREEN LED. TRIM LEADS TO 5mm.
- SOLDER WIRE LEADS TO LEAD LEADS.
- SSH-LXH1612BSG, BUSHING, INSERT AND CRIMP.
- ANODE LEAD: LXP-WST26RDT0C, 26 AWG, STRANDED, RED INSULATION. CUT 257mm LONG, STRIP END 2mm & 9.5mm.
- CATHODE LEAD: LXP-WST26BLT0C, 26 AWG, STRANDED, BLACK INSULATION. CUT 257mm LONG, STRIP END 2mm & 9.5mm.

*UNLESS OTHERWISE SPECIFIED TOLERANCES PER DECIMAL PRECISION ARE: X=±1 (±0.039), X.X=±0.5 (±0.020), X.XX=±0.25 (±0.010), X.XXX=±0.127 (±0.005). LEAD SIZE=±0.05 (±0.002), LEAD LENGTH=±0.75 (±0.030). MIN= $\frac{+DECIMAL}{-0.00}$ PRECISION MAX.= $\frac{+0.00}{-DECIMAL}$ PRECISION



425 N. GARY AVE.
CAROL STREAM, IL 60188-4900
PHONE: +1.800.278.5666
FAX: +1.630.315.2152
WEB: WWW.LUMEX.COM
MEMBER OF ITW PHOTONICS GROUP

T-3mm (T-1) 565nm GREEN LED PANEL INDICATOR, GREEN DIFFUSED LENS, 9.8" WIRE LEADS.

THE SPECIFICATIONS MAY CHANGE AT ANY TIME WITHOUT NOTICE DUE TO NEW MATERIALS OR PRODUCT IMPROVEMENT.

CONFIDENTIAL INFORMATION
THE INFORMATION CONTAINED IN THIS DOCUMENT IS THE PROPERTY OF LUMEX INC. EXCEPT AS SPECIFICALLY AUTHORIZED IN WRITING BY LUMEX INC., THE HOLDER OF THIS DOCUMENT SHALL KEEP ALL INFORMATION CONTAINED HEREIN CONFIDENTIAL AND SHALL PROTECT SAME IN WHOLE OR IN PART FROM DISCLOSURE AND DISSEMINATION TO ALL THIRD PARTIES.

DATE:	07.02.14	DRAWN BY:	MA
PAGE:	1 OF 1	CHKD BY:	SS
SCALE:	NTS	APRVD BY:	KF
UNIT:	mm [INCH]		Ⓟ