

LOC		DIST		REVISIONS			
AA	22	F	LTR	DESCRIPTION	DATE	DMN	APVD
		A		REV PER EC 0511-0201-04	15JUN2005	LV	SF
		A1		REVISED PER ECO-09-024927	10NOV09	KK	AEG

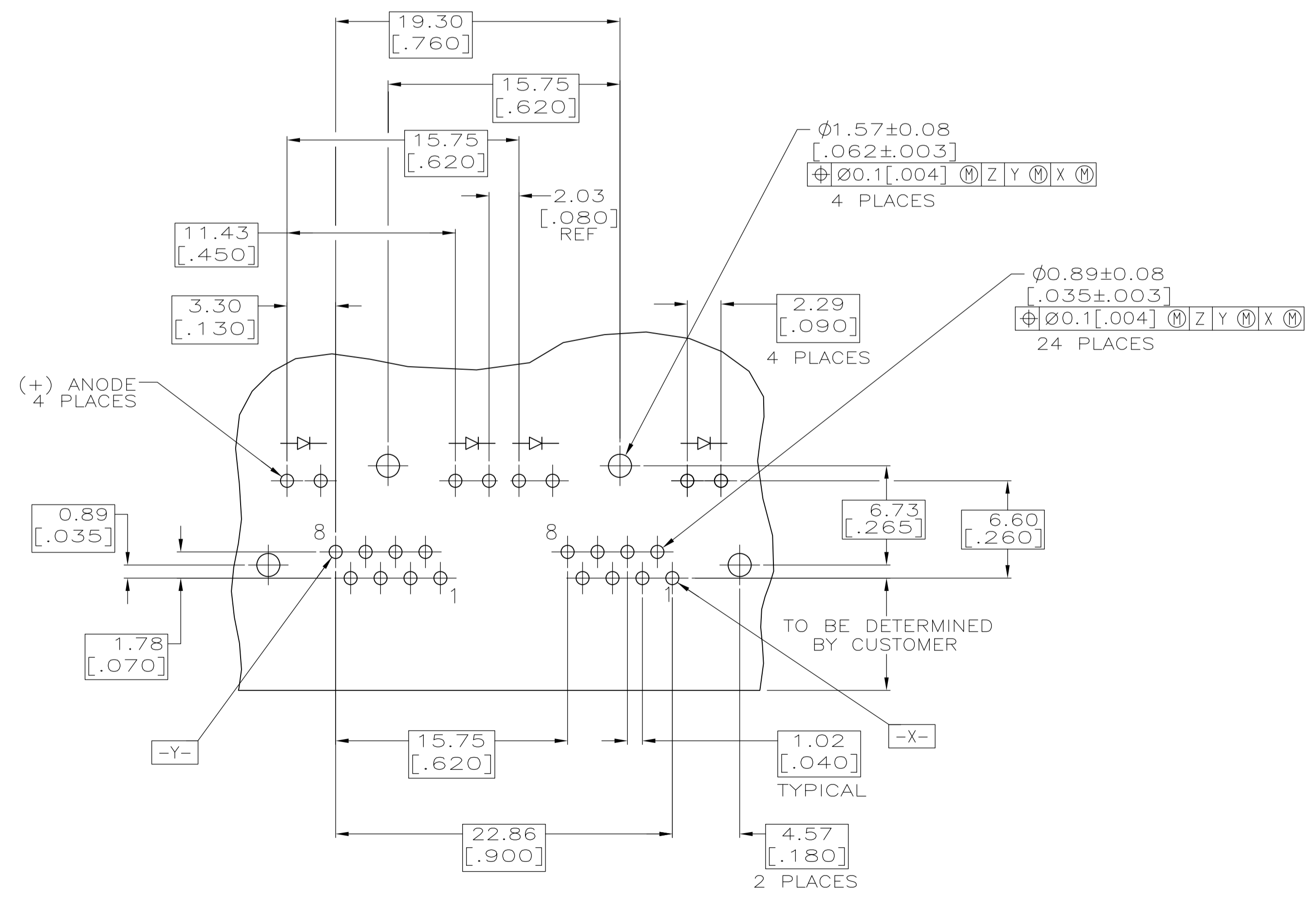
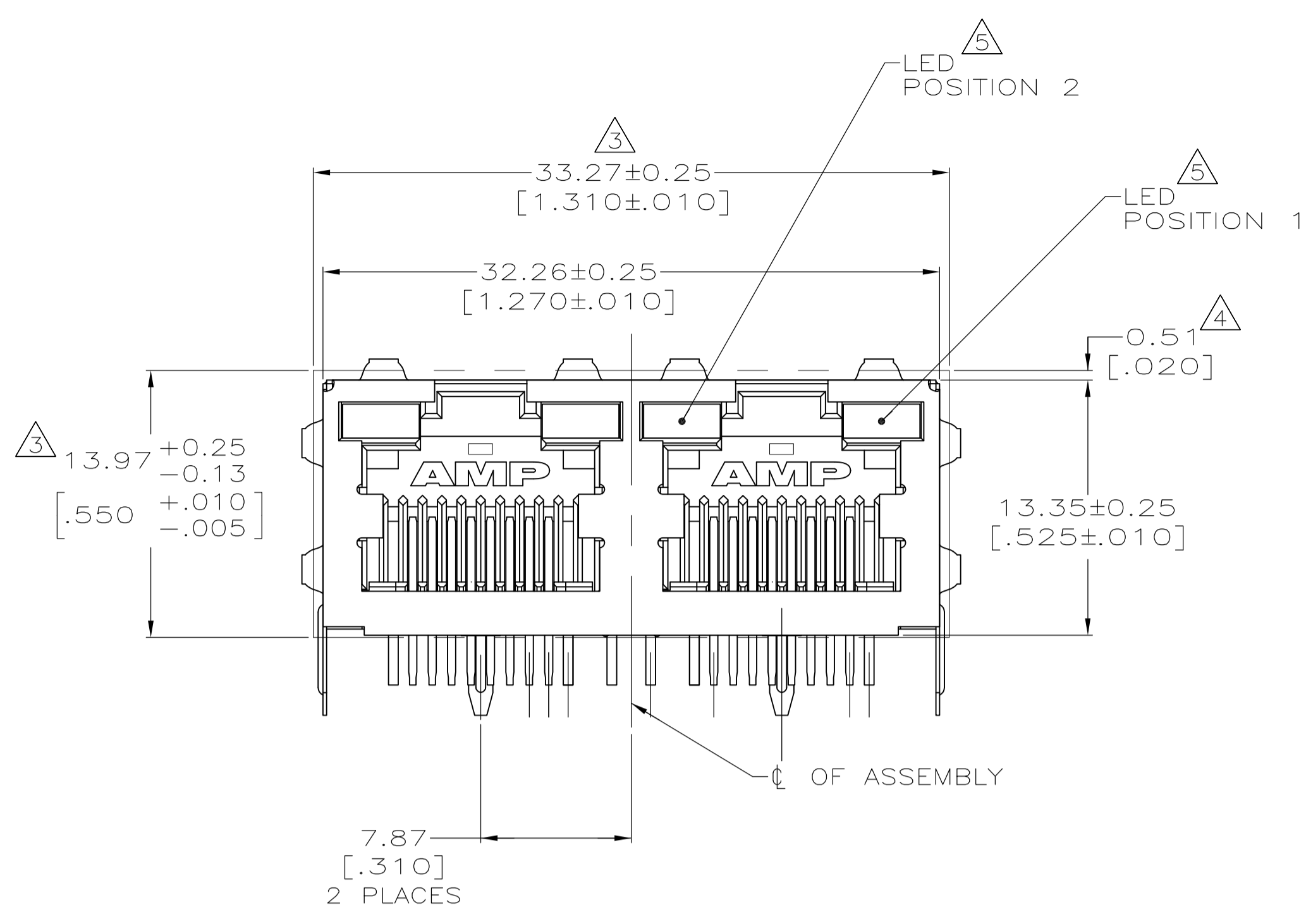
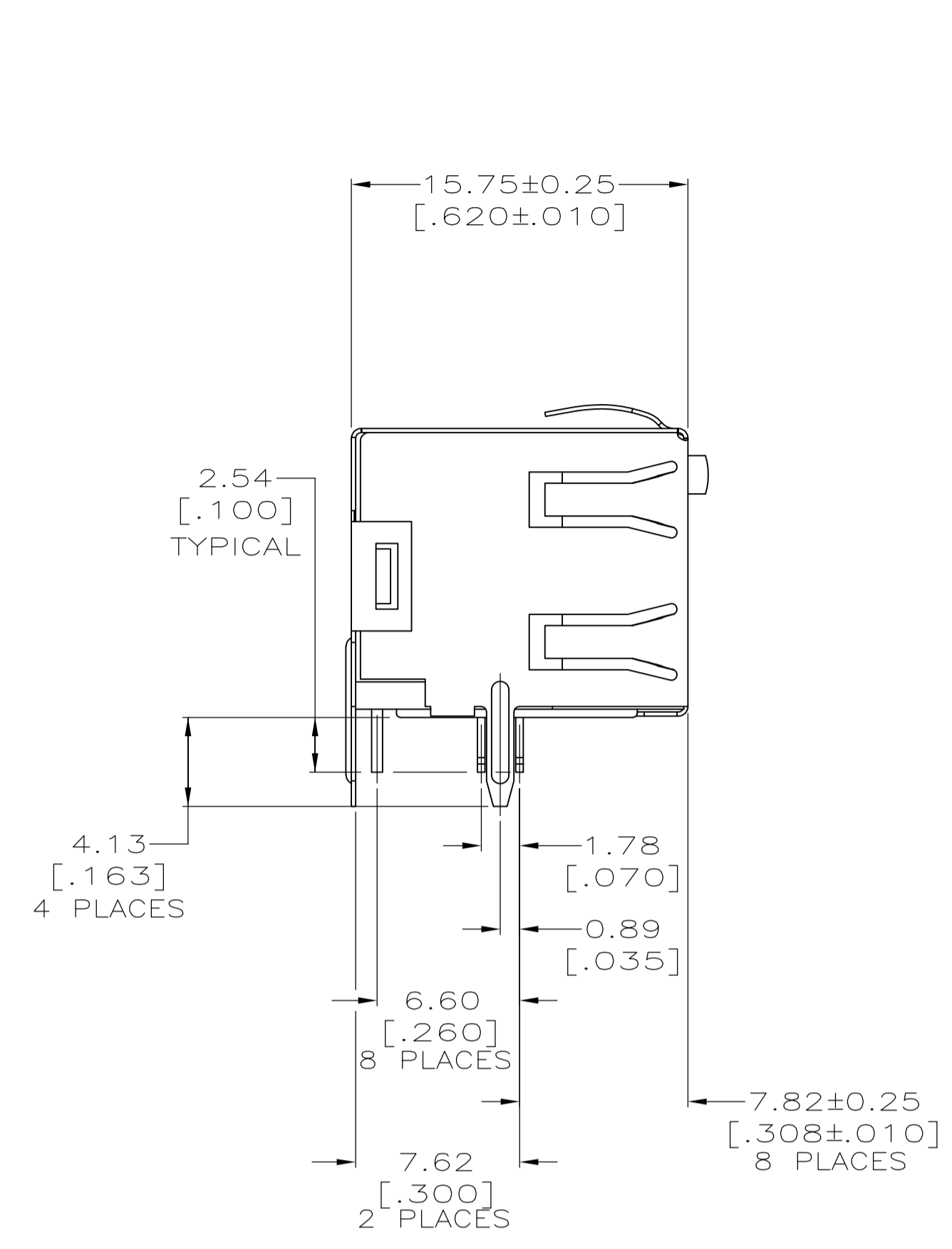

- MATERIAL:**
 HOUSING - HIGH TEMPERATURE THERMOPLASTIC, BLACK, UL94V-0.
 TERMINALS - 0.36[.014] THICK PHOS BRONZE PLATED WITH 3.81µm[.000150] MINIMUM THICK MATTE TIN IN SOLDER AREA. 1.27µm [.000050] MINIMUM GOLD IN LOCALIZED PLATE AREA. ENTIRE TERMINAL PLATED WITH 1.27µm [.000050] MINIMUM THICK NICKEL.
 SHIELD - 0.196[.0077] THICK COPPER ZINC ALLOY PREPLATED WITH 1.27µm[.000050] MINIMUM SATIN NICKEL WITH 2.03µm[.000080] MINIMUM HOT TIN DIP ON PCB GROUND TABS.
 LIGHT EMITTING DIODE (LED) - DIFFUSED EPOXY LENS, 0.51 x 0.51[.020 x .020] CARBON STEEL WIREFRAME LEADS PREPLATED WITH 8.89 µm[.0003500] THICK Sn/Cu OVER 2.03 µm[.000080] THICK Ag OVER 1.02µm[.000040] THICK Cu OVER 3.56 µm[.000140] THICK Ni OVER 1.02µm[.000040] Cu UNDERPLATE
- JACK CAVITY CONFORMS TO FCC RULES AND REGULATIONS PART 68, SUBPART F.
 - SUGGESTED PANEL OPENING DIMENSIONS.
 - SUGGESTED CLEARANCE BETWEEN TOP OF CONNECTOR AND TOP PANEL OPENING.
 - SEE TABLE FOR COLOR OF LEDS AND NUMBER REQUIRED.
 - THIS MODULAR JACK WITH INTEGRATED LED IS NOT IR REFLOW SOLDERING PROCESS COMPATIBLE.
 - OBSOLETE PARTS: OBSOLETE CIS STREAMLINING PER D.RENAUD/D.SINISI

SUGGESTED PRINTED CIRCUIT BOARD LAYOUT
 (COMPONENT SIDE)

INDICATOR COLOR FOR EACH HOUSING	POSITION 2	POSITION 1	PART NUMBER
GREEN	GREEN	GREEN	6364173-5
YELLOW	GREEN	GREEN	-6364173-1

THIS DRAWING IS A CONTROLLED DOCUMENT.		DIN L. VARELA - DOCKS 15JUN2005		Tyco Electronics Corporation	
DIMENSIONS: mm [INCHES]		CHK J. WESTMAN 15JUN2005		Harrisburg, Pa 17105-3608	
TOLERANCES UNLESS OTHERWISE SPECIFIED:		APVD S. FLICKINGER 15JUN2005		NAME	
0. PLC	± -	PRODUCT SPEC		INVERTED MODULAR JACK ASSEMBLY, 1X2, PANEL GROUND, SHIELDED, NO MOUNTING LEGS, WITH LEDS	
1. PLC	± -	APPLICATION SPEC		108-1163-4	
2. PLC	± 0.25[.01]	SIZE		114-2154	
3. PLC	± 0.13[.005]	WEIGHT		A1 00779 C=6364173	
4. PLC	± -	CUSTOMER DRAWING		SCALE 1:1 SHEET 1 OF 1 REV A1	